

INSTRUCTIONS

INSTALLATION OF TOP AND BOTTOM COVERS FOR IP00 FRAMES D3, D4 & E2 INTO RITTAL ENCLOSURES

This instruction sheet is for the installation of the top and bottom covers onto IP00 VLTs[®] to direct the heat sink cooling air in and out the back of the frequency converter. The kits are applicable to IP00 drive frames D3, D4 and E2. These kits are designed and tested to be used with IP00/Chassis drives in Rittal TS8 enclosures.

Notes:

1. If external duct work is added to the exhaust path of the drive, additional back pressure will be created that will reduce the cooling of the drive. The drive must be derated to accommodate the reduced cooling. First, the pressure drop must be calculated, then refer to the derating tables located in the VLT High Power Operating Instructions.
2. A doorfan(s) is required on the enclosure to remove the heat losses not contained in the backchannel of the drive and any additional losses generated from other components installed inside the enclosure. The total required air flow must be calculated so that the appropriate fans can be selected. Some enclosure manufacturers offer software for performing the calculations (i.e. Rittal Therm software).

If the VLT is the only heat generating component in the enclosure, the minimum airflow required at an ambient temperature of 45°C for the D3 and D4 frame drives is 391 m³/h (230 cfm). The minimum airflow required at an ambient temperature of 45°C for the E2 frame drive is 782 m³/h (460 cfm).

Used with:	
VLT4000, VLT5000, VLT6000, VLT8000, VLT-HVAC, VLT-AQUA, VLT-Automation	
Frame D3 Kit Part No.	176F1781
Frame D4 Kit Part No.	176F1782
Frame E2 Kit Part No.	176F1783

Required Tools

- Metric Socket Set, 7-19mm
- Socket Extensions
- Torx Driver Set T10-T40
- Torque Wrench 6-50 in-lbs (.7-6 N-M)

Torque Requirements

1. M5 screws/nuts torque to 20 in-lbs (2.3 N-M)
2. M6 screws/nuts torque to 35 in-lbs (3.9 N-M)
3. M10 nuts torque to 170 in-lbs (20 N-M)
4. T25 Torx screws torque to 20 in-lbs (2.3 N-M)

The kit consist of the following parts:

- Drive mounting plate
- Top vent cover
- Bottom air inlet cover
- Sealing plates
- Gasket material
- Hardware

Note: The photos in this Instruction Sheet represent a D-Frame drive. E-Frame drives use parts similar to those in the photos however they are sized appropriately for the E-Frame drives.

Remove the screws from the top of drive. Note: remove only the screws located toward the rear of the drive. Do not remove the screws that are securing the fan in place. See Figure 1.

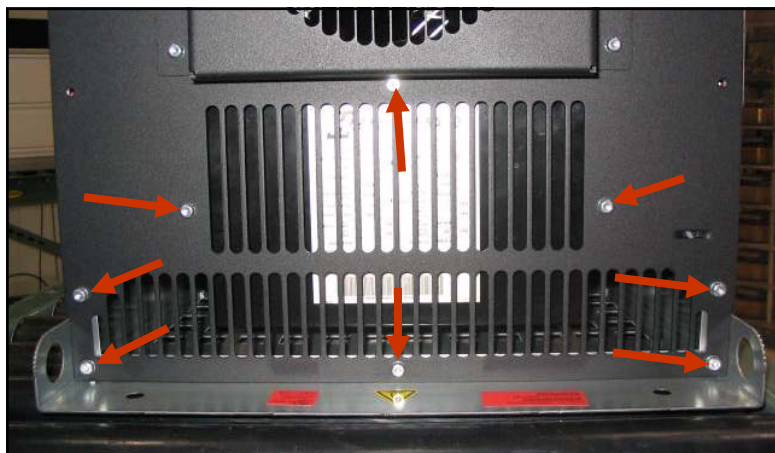

Figure 1. Screws to be removed from top of drive

Install the gasket on the top cover plate as shown in Figure 2.

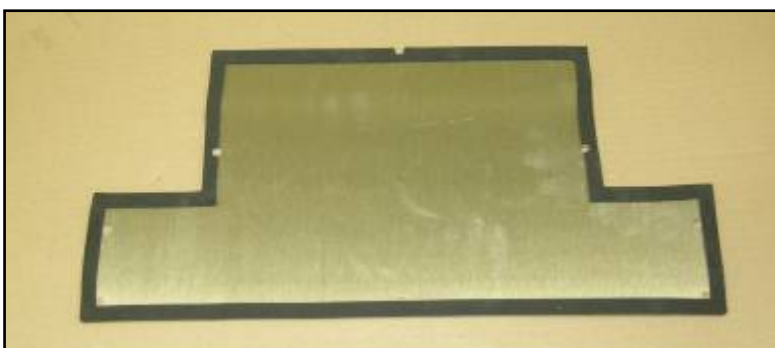

Figure 2. Gasket applied to top cover plate

Install the top duct cover plate as shown in Figure 3 using the new 16mm, M5 screws provided with the kit.



Figure 3. Top cover plate installed

Install the two mounting brackets on the bottom of the frame as shown. Note that the E2 frame VLT utilizes six mounting brackets for the bottom cover plate. See Figures 4 and 5.



Figure 4. Bottom plate mounting brackets

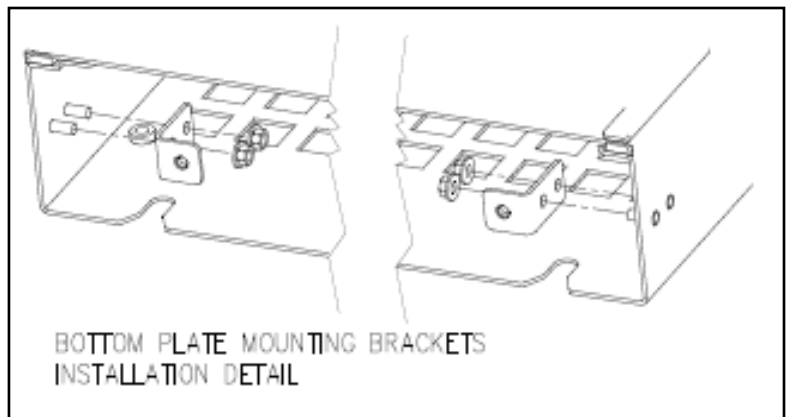

Figure 5. Bottom plate mounting detail

Mount the drive mounting plate in the enclosure using the “in frame” mounting position. See Figure 6.



Figure 6. Drive mounting plate installed with rear panel of enclosure removed

Use the drive mounting plate as a template to mark the openings for the air intake and exhaust along with mounting screw holes on the rear panel of the enclosure.

Remove the rear panel of the enclosure and cut openings and drill mounting holes. See Figure 7.



Figure 7. Rear panel of enclosure

Install gasket material on both sides of the drive mounting plate. See Figure 8.



Figure 8. Back of drive mounting plate with gasket installed

Install the drive on the drive mounting plate using the four studs on the top and bottom of the mounting plate. M10 nuts are provided for drive mounting. See Figures 9 and 10.

Install seal plates prior to installing hardware on bottom studs. Refer to Figures 11 - 14.



Figure 9. Drive installed on mounting plate

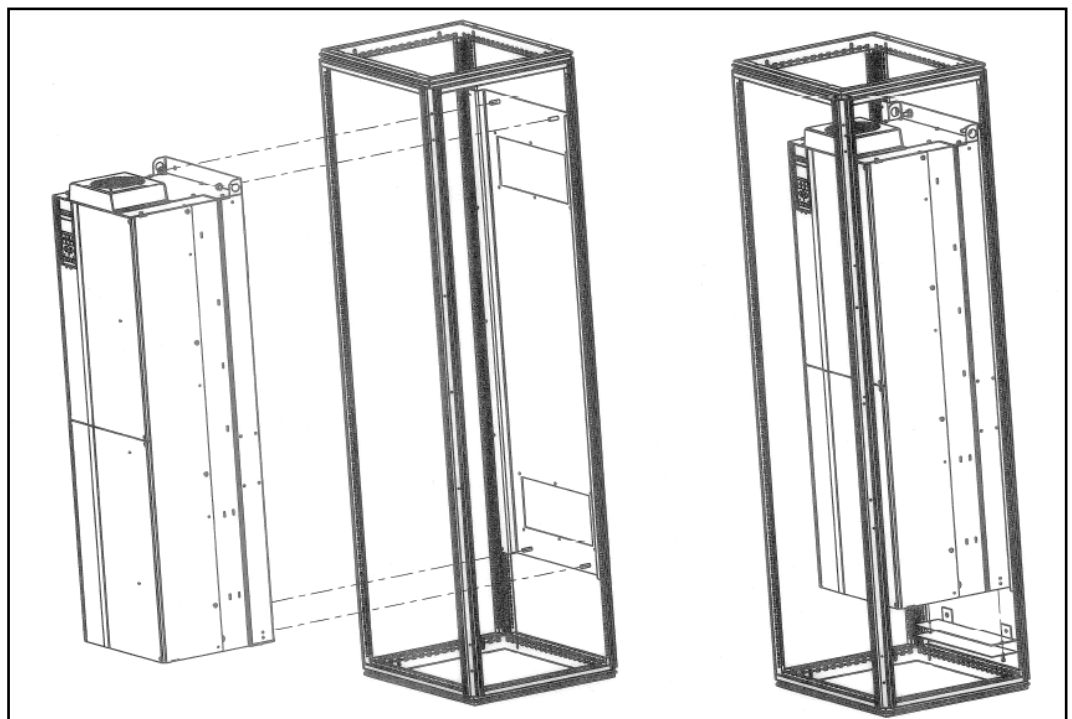

Figure 10. Breakaway view of drive installation.

Two sealing plates and gaskets are provided in the kit. See Figure 11.

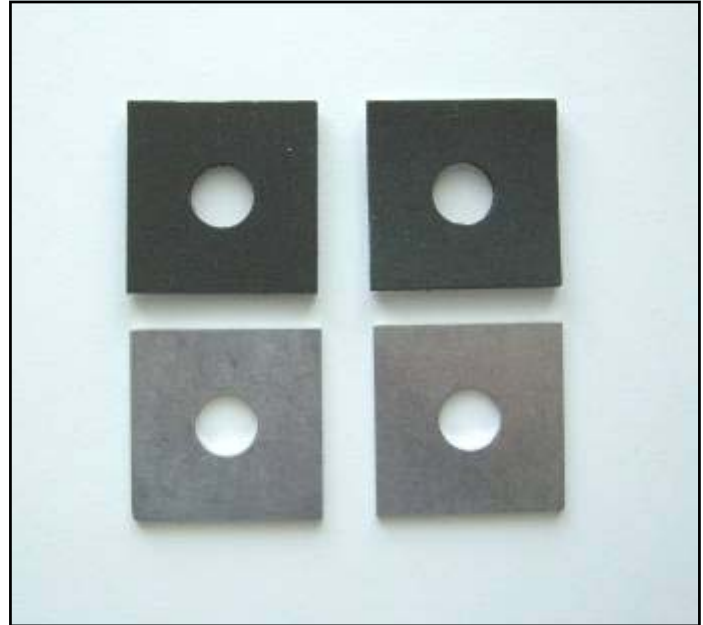

Figure 11. Sealing plates and gaskets

Apply gaskets to the sealing plates as shown in Figure 12.



Figure 12. Gasket mounted on sealing plate

Install the sealing plates over the two bottom drive mounting studs and secure the drive with nuts. See Figures 13 and 14.

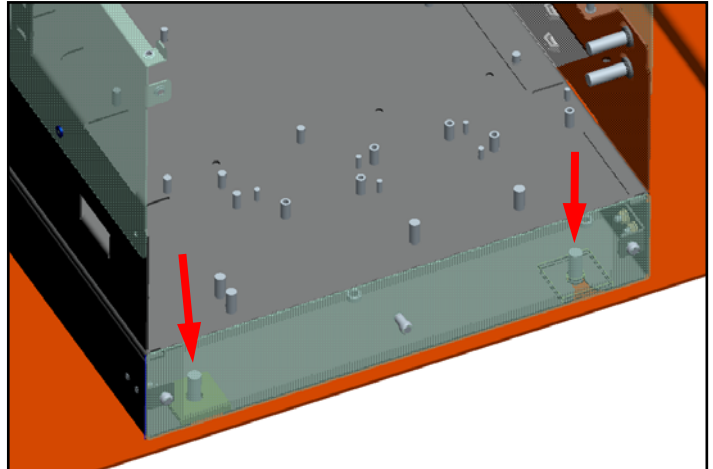

Figure 13. Bottom mounting locations

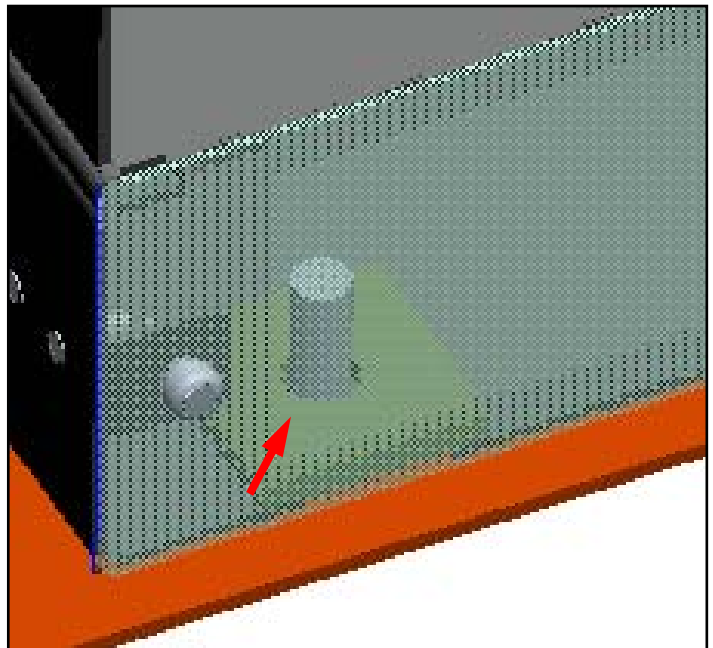

Figure 14. Sealing plate installed over mounting stud

Install the gasket on the bottom cover plate as shown in Figure 15.



Figure 15. Bottom cover with gasket

Install the bottom cover plate as shown in Figure 16.

A drain hose may be attached to the drain plug if there is concern that condensation may accumulate in the bottom of the duct. If not, plug the drain plug with a screw provided with the kit. It is recommended that Teflon tape be used with the screw to seal the drain plug.



Figure 16. Bottom air inlet cover installed