

INSTRUCTIONS

INSTALLATION OF TOP AND BOTTOM COVERS FOR D- and E-FRAME VLT® DRIVES INTO WELDED ENCLOSURES

This instruction sheet is for the installation of top and bottom covers for the D- and E-Frame VLT® drives. These kits are designed to be used to direct the back-channel airflow in and out the back of the drive as opposed to in the bottom and out the top of the drive (when the drives are being mounted directly on a wall or inside a welded enclosure).

Notes:

1. If external duct work is added to the exhaust path of the drive, additional back pressure will be created that will reduce the cooling of the drive. The drive must be derated to accommodate the reduced cooling. First, the pressure drop must be calculated, then refer to the derating tables located in the VLT High Power Operating Instructions.
2. When installed in an enclosure, a doorfan(s) is required on the enclosure to remove the heat losses not contained in the backchannel of the drive and any additional losses generated from other components installed inside the enclosure. The total required air flow must be calculated so that the appropriate fans can be selected.

If the VLT is the only heat generating component in the enclosure, the minimum airflow required at an ambient temperature of 45°C for the D3 and D4 frame drives is 391 m³/h (230 cfm). The minimum airflow required at an ambient temperature of 45°C for the E2 frame drive is 782 m³/h (460 cfm).

Used with: VLT4000, VLT5000, VLT6000, VLT8000, VLT-HVAC, VLT-AQUA, VLT-Automation	
D-Frame Kit Part No.	176F1862
E-Frame Kit Part No.	176F1861

Kit Contents

- Top and bottom cover plates
- Sealing plates
- Gaskets
- Mounting hardware

Required Tools

- Metric Socket Set, 7-19mm
- Socket Extensions
- Torx Driver Set T10-T40
- Torque Wrench 6-50 in-lbs (.7-6 N-M)

Torque Requirements

1. M5 screws/nuts torque to 20 in-lbs (2.3 N-M)
2. M6 screws/nuts torque to 35 in-lbs (3.9 N-M)
3. M10 nuts torque to 170 in-lbs (20 N-M)
4. T25 Torx screws torque to 20 in-lbs (2.3 N-M)

Note: The photos in this Instruction Sheet represent a D-Frame drive. E-Frame drives use parts similar to those in the photos however they are sized appropriately for the E-Frame drives.

Remove the screws from the top of drive. Note: remove only the screws located toward the rear of the drive. Do not remove the screws that are securing the fan in place. See Figure 1.

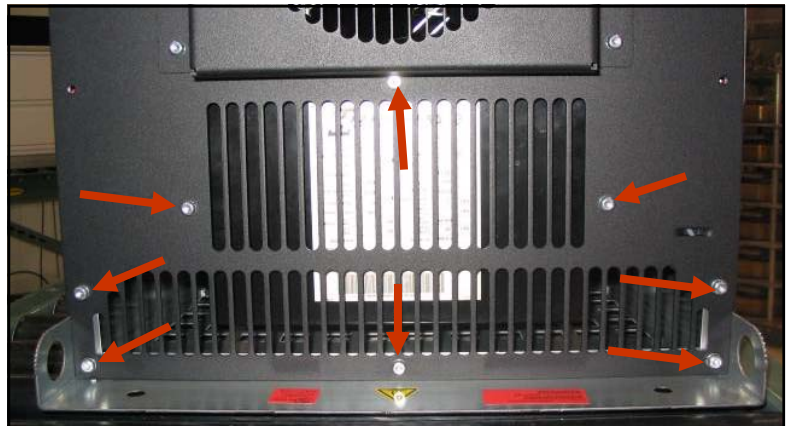

Figure 1. Screws to be removed from top of drive

Install the gasket on the top cover plate as shown in Figure 2.



Figure 2. Gasket applied to top cover plate

Install the top duct cover plate as shown in Figure 3 using the new 16mm, M5 screws provided with the kit



Figure 3. Top cover plate installed

Install the two mounting brackets on the bottom of the frame as shown. See Figures 4 and 5. Note that the E2 frame VLT utilizes six mounting brackets for the bottom cover plate.



Figure 4. Bottom plate mounting brackets

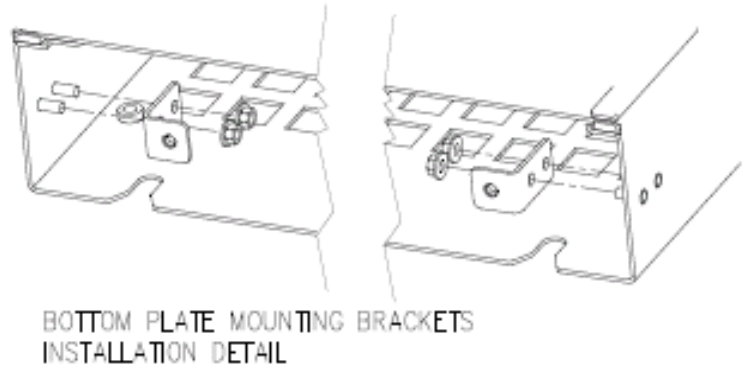

Figure 5. Bottom plate mounting detail

Install gasket around the back air inlet vent and air outlet vents located on the back of the VLT. See Figure 6.

Mount the drive on the wall or inside the enclosure.

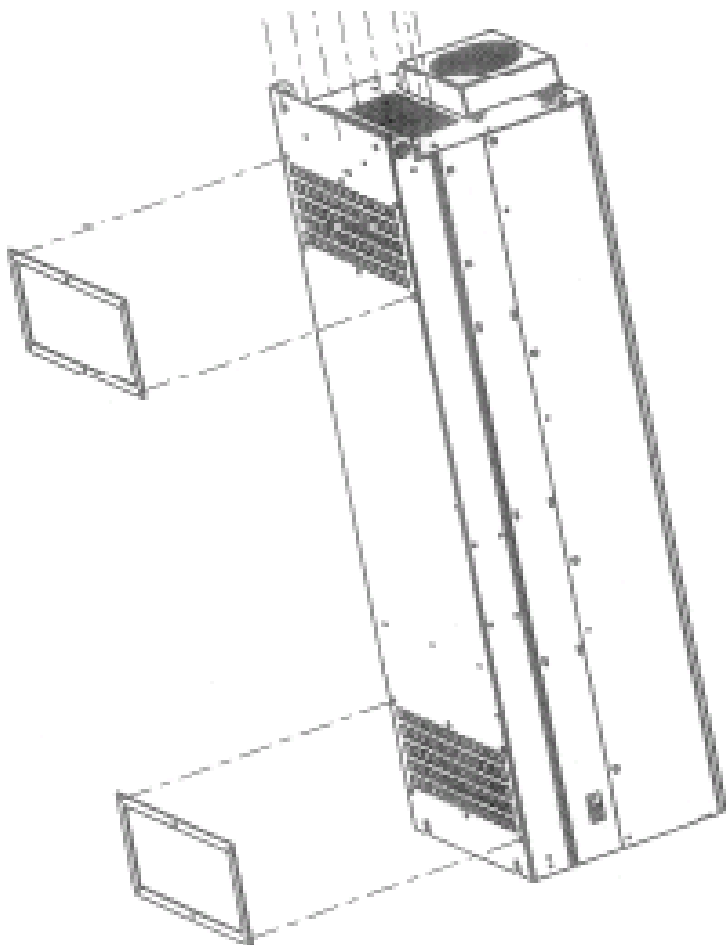

Figure 6. Breakaway view of gaskets on back of drive

Two sealing plates and gaskets are provided in the kit. See Figure 7. The sealing plates are used if the drive is being installed inside of an enclosure.

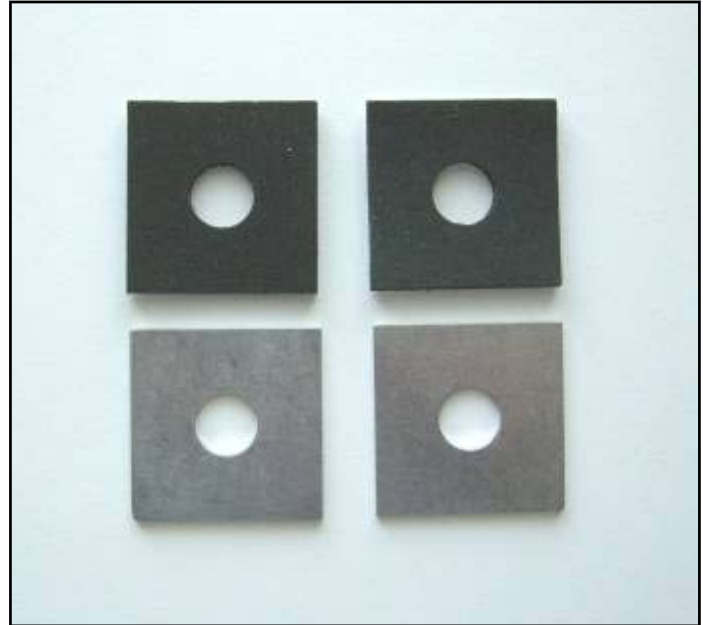

Figure 7. Sealing plates and gaskets

Apply gaskets to the sealing plates as shown in Figure 8.



Figure 8. Gasket mounted on sealing plate

Install the sealing plates over the two bottom drive mounting studs and secure the drive with nuts. See Figures 9 and 10.

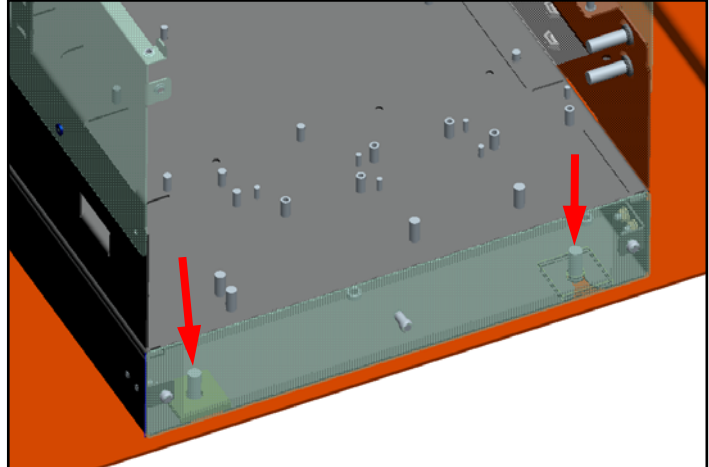

Figure 9. Bottom mounting locations

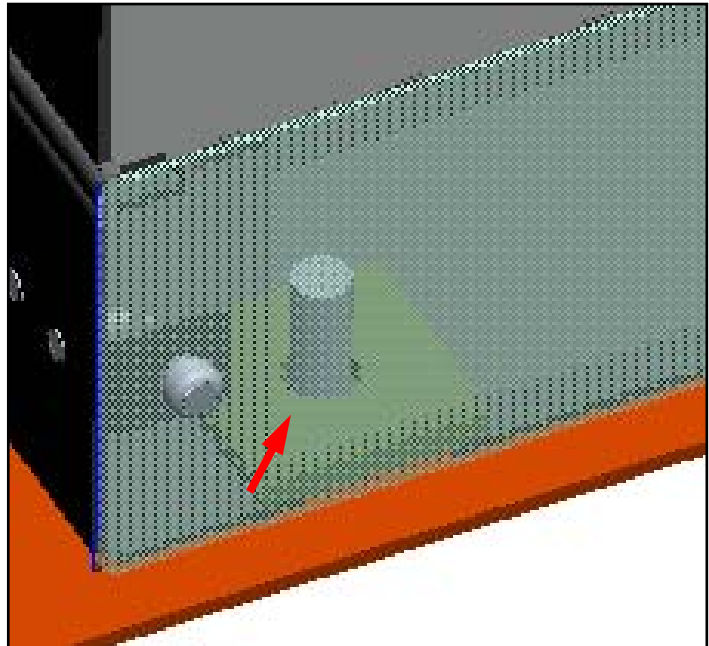

Figure 10. Sealing plate installed over mounting stud

Install the gasket on the bottom cover plate. See Figure 11.



Figure 11. Bottom cover with gasket

Install the bottom cover plate as shown in Figure 12.

A drain hose may be attached to the drain plug if there is concern that condensation may accumulate in the bottom of the duct. If not, plug the drain plug with a screw provided with the kit. It is recommended that Teflon tape be used with the screw to seal the drain plug.



Figure 12. Bottom air inlet cover installed