

VACON[®] NX
AC DRIVES

LIQUID-COOLED DRIVES
USER MANUAL

VACON[®]

TABLE OF CONTENTS

Document: DPD00887E

Release date : 25/10/16

1.	Safety	6
1.1	Safety symbols used in the manual	6
1.2	Danger	7
1.3	Warnings	7
1.4	Grounding and earth fault protection	8
1.5	Running the motor	10
2.	EU directive	11
2.1	CE marking	11
2.2	EMC directive	11
2.2.1	General	11
2.2.2	Technical criteria	11
2.2.3	VACON® AC drive EMC classification	11
2.2.4	Explanations of voltage classes	12
2.2.5	Manufacturer's declaration of conformity	13
3.	Receipt of delivery	14
3.1	Type designation code	14
3.2	Storage and shipping	15
3.3	Maintenance	15
3.4	Warranty	18
4.	Technical data	19
4.1	Introduction	19
4.2	Power ratings	22
4.2.1	AC drives	22
4.2.2	Inverter units	28
4.3	Technical data	31
5.	Installation	36
5.1	Mounting	36
5.1.1	Lifting the drive	36
5.1.2	VACON® NX Liquid-Cooled dimensions	38
5.2	Cooling	53
5.2.1	Condensation	60
5.2.2	Cooling system connections	61
5.3	Drive derating	67
5.4	Input chokes	69
5.4.1	Installation of input chokes	70
6.	Electrical cabling and connections	74
6.1	Power unit	74
6.1.1	Power connections	74
6.1.2	Drive protection – Fuses	81
6.1.3	Fuse sizes	81
6.1.4	Cable installation instructions	87
6.1.5	Supply busbars for inverter units	90
6.1.6	Installation space	91
6.1.7	Grounding of power unit	91
6.1.8	Installation of ferrite rings (option) on the motor cable	92
6.1.9	Cable installation and the UL standards	92
6.1.10	Cable and motor insulation checks	93
6.2	Control unit	94
6.2.1	Control board power-up	96
6.2.2	Control connections	96

6.2.3	Control terminal signals	98
6.2.4	Control unit mounting box	103
6.3	Internal connections	106
6.3.1	Connections between Power Unit ASIC and Driver Boards	106
6.3.2	Connections between power unit ASIC and the control unit.....	109
6.3.3	Connections between mains device and inverter power module	113
7.	Control keypad	116
7.1	Indications on the Keypad display	116
7.1.1	Drive status indications	116
7.1.2	Control place indications	117
7.1.3	Status LEDs (green – green – red)	117
7.1.4	Text lines	117
7.2	Keypad push-buttons	118
7.2.1	Button descriptions.....	118
7.3	Navigation on the control keypad	119
7.3.1	Monitoring menu (M1).....	120
7.3.2	Parameter menu (M2).....	122
7.3.3	Keypad control menu (M3)	123
7.3.4	Active faults menu (M4)	125
7.3.5	Fault history menu (M5).....	127
7.3.6	System menu (M6)	128
7.3.7	Expander board menu (M7).....	141
7.4	Further keypad functions.....	142
8.	Commissioning	143
8.1	Safety.....	143
8.2	Commissioning of the AC drive.....	144
9.	Fault tracing.....	146
9.1	Fault codes.....	146
9.2	Load test with motor	152
9.3	DC link test (without motor).....	153
10.	Active front end (NXA).....	154
10.1	Introduction	154
10.2	Diagrams	154
10.2.1	Active Front End Unit block diagram.....	154
10.3	Type designation code.....	155
10.4	Active Front End unit technical data.....	156
10.5	Power ratings	160
10.6	Liquid-Cooled RLC filters	162
10.6.1	Introduction	162
10.6.2	Wiring diagrams.....	162
10.6.3	Power rating and dimensions	163
10.6.4	Technical data	165
10.6.5	Removing discharging resistors	165
10.6.6	Removing HF capacitors	166
10.7	Active front end - fuse selection	168
10.7.1	Fuse sizes, Active Front End units (AC supply)	168
10.8	Pre-Charging circuit	170
10.9	Parrelling.....	172
10.10	Common pre-charging circuit	173
10.11	Each Active Front End unit has the pre-charging circuit	174
11.	Non-regenerative front end	175
11.1	Introduction	175
11.2	Diagrams	175

11.2.1 Non-regenerative Front End Unit wiring diagrams	175
11.3 Installation of the NFE control cables	178
11.4 Type designation codes	179
11.5 Power ratings	180
11.6 Non-regenerative Front End unit technical data	181
11.7 Dimensions	183
11.8 Chokes	184
11.9 Non-regenerative front end - fuse selection	185
11.9.1 Fuse sizes, Non-regenerative Front End units	186
11.9.2 Circuit breaker settings, Non-regenerative Front End units	186
11.10 Settings	186
11.10.1 Phase monitor settings	186
11.10.2 Option board settings	187
11.11 DC pre-charging circuit	188
11.12 Paralleling	189
11.13 Parameters	190
11.14 CH60 Liquid-cooled NFE protections	195
11.15 Fault codes	196
12. Brake chopper unit (NXB)	199
12.1 Introduction	199
12.2 Type designation code	199
12.3 Diagrams	199
12.3.1 NXB Brake Chopper Unit block diagram	199
12.3.2 VACON® NXB topologies and connection	200
12.4 Brake chopper unit technical data	201
12.5 BCU power ratings	204
12.5.1 VACON® NXB; DC voltage 460–800 V	204
12.5.2 VACON® NXB; DC voltage 640–1100 V	205
12.6 VACON® brake resistors and brake chopper dimensioning	206
12.6.1 Braking energy and losses	206
12.6.2 Braking power and resistance, mains voltage 380–500 Vac/600–800 Vdc	208
12.6.3 Braking power and resistance, mains voltage 525–690 Vac/840–1100 Vdc	210
12.7 Brake chopper unit – Fuse selection	212
13. Appendices	214

AT LEAST THE FOLLOWING STEPS OF THE START-UP QUICK GUIDE MUST BE PERFORMED DURING THE INSTALLATION AND COMMISSIONING.**IF ANY PROBLEMS OCCUR, CONTACT YOUR LOCAL DISTRIBUTOR.****Start-up Quick Guide**

1. Check that the delivery corresponds to your order, see Chapter 3.
2. Before taking any commissioning actions read carefully the safety instructions in Chapter 1.
3. Check the size of the motor cable, mains cable, mains fuses and check the cable connections, read Chapter 6.1.1.1 – Chapter 6.1.2.
4. Follow the installation instructions.
5. Control connections are explained in Chapter 6.2.2.
6. Ensure the adequate pressure and flow of the cooling agent you are using. See Chapter 5.2.
7. If the Start-Up wizard is active, select the language of the keypad and the application you want to use and confirm by pressing the Enter button. If the Start-Up wizard is not active, follow the instructions 7a and 7b.
 - 7a. Select the language of the keypad from the Menu M6, S6.1. Instructions on using the keypad are given in Chapter 7.
 - 7b. Select the application you want to use from the Menu M6, S6.2. Instructions on using the keypad are given in Chapter 7.
8. All parameters have factory default values. In order to ensure proper operation, check the rating plate data for the values below and the corresponding parameters of parameter group G2.1.
 - nominal voltage of the motor
 - nominal frequency of the motor
 - nominal speed of the motor
 - nominal current of the motor
 - motor $\cos\phi$All parameters are explained in VACON[®] NX All in One Application Manual.
9. Follow the commissioning instructions, see Chapter 8.
10. The VACON[®] NX Liquid-Cooled AC drive is now ready for use.

Vacon Ltd is not responsible for the use of its products against instructions.

ABOUT THE VACON® NX LIQUID-COOLED AC DRIVES USER MANUAL

Congratulations for choosing the Smooth Control provided by VACON® NX_W Liquid-Cooled drives!

This manual will provide you with the necessary information about the installation, commissioning and operation of VACON® NX Liquid-Cooled drives. We recommend that you carefully study these instructions before powering up the AC drive for the first time.

This manual is available in both paper and electronic editions. We recommend you to use the electronic version if possible. If you have the electronic version at your disposal you will be able to benefit from the following features:

The manual contains several links and cross-references to other locations in the manual which makes it easier for the reader to move around in the manual, to check and find things faster.

The manual also contains hyperlinks to web pages. To visit these web pages through the links you must have an internet browser installed on your computer.

1. SAFETY



ONLY A COMPETENT ELECTRICIAN MAY CARRY OUT THE ELECTRICAL INSTALLATION!

1.1 SAFETY SYMBOLS USED IN THE MANUAL

This manual contains warnings and cautions, which are identified with safety symbols. The warnings and cautions give important information on how to prevent injury and damage to the equipment or your system.

Read the warnings and cautions carefully and obey their instructions.

	= DANGEROUS VOLTAGE!
	= GENERAL WARNING!

1.2 DANGER



Do not touch the components of the power unit when the drive is connected to mains. The components are live when the drive is connected to mains. A contact with this voltage is very dangerous.



Do not touch the motor cable terminals U, V, W, the brake resistor terminals or the DC terminals when the drive is connected to mains. These terminals are live when the drive is connected to mains, also when the motor does not operate.



Do not touch the control terminals. They can have a dangerous voltage also when the drive is disconnected from mains.



Before you do electrical work on the drive, disconnect the drive from the mains and make sure that the motor has stopped. Lock out and tag out the power source to the drive. Make sure that no external source generates unintended voltage during work. Note that also the load side of the drive can generate voltage.



Wait 5 minutes before you open the cabinet door. Use a measuring device to make sure that there is no voltage. The terminal connections and the components of the drive can be live 5 minutes after it is disconnected from the mains and the motor has stopped.



Before you connect the AC drive to mains, make sure that the coolant circulation functions properly, and check the circulation for possible leaks.



Before you connect the drive to mains, make sure that the front cover and the cable cover of the drive are closed. The connections of the AC drive are live when the drive is connected to mains.



Before connecting the drive to mains make sure that the enclosure door is closed.



Disconnect the motor from the drive if an accidental start can be dangerous. When there is a power-up, a power break or a fault reset, the motor starts immediately if the start signal is active, unless the pulse control for Start/Stop logic is selected. If the parameters, the applications or the software change, the I/O functions (including the start inputs) can change.



Wear protective gloves when you do mounting, cabling or maintenance operations. There can be sharp edges in the AC drive that can cause cuts.

1.3 WARNINGS



Do not move the AC drive. Use a fixed installation to prevent damage to the drive.



Do not make measurements when the AC drive is connected to mains. It can cause damage to the drive.



Make sure that there is reinforced protective ground connection. It is mandatory, because the touch current of the AC drives is more than 3.5 mA AC (refer to EN 61800-5-1). See Chapter 1.4.



Do not use spare parts that are not from the manufacturer. Using other spare parts can cause damage to the drive.



Before you make measurements on the motor or the motor cable, disconnect the motor cable from the AC drive.



Do not lift the AC drive from the plastic handles with an elevating device, such as jib crane or hoist.



Do not touch the components on the circuit boards. Static voltage can cause damage to these components.



Make sure that the EMC level of the AC drive is correct for your mains. Contact your local distributor for instructions. An incorrect EMC level can cause damage to the drive.



Prevent radio interference. The AC drive can cause radio interference in a domestic environment.

NOTE!

If you activate the autoreset function, the motor starts automatically after an automatic fault reset. See the Application Manual.

NOTE!

If you use the AC drive as a part of a machine, the machine manufacturer must supply a mains disconnection device (refer to EN 60204-1).

1.4 GROUNDING AND EARTH FAULT PROTECTION



The AC drive must always be grounded with a grounding conductor that is connected to the grounding terminal that is identified with the symbol ⏚ . Not using a grounding conductor can cause damage to the drive.

The touch current of the drive is more than 3.5 mA AC. The standard EN 61800-5-1 tells that 1 or more of these conditions for the protective circuit must be true.

The connection must be fixed.

- a) The protective grounding conductor must have a cross-sectional area of minimum 10 mm² Cu or 16 mm² Al. OR
- b) There must be an automatic disconnection of the mains, if the protective grounding conductor breaks. See Chapter 6. OR
- c) There must be a terminal for a second protective grounding conductor in the same cross-sectional area as the first protective grounding conductor.

Table 1. Protective grounding conductor cross-section

Cross-sectional area of the phase conductors (S) [mm ²]	The minimum cross-sectional area of the protective grounding conductor in question [mm ²]
$S \leq 16$	S
$16 < S \leq 35$	16
$35 < S$	S/2

The values of the table are valid only if the protective grounding conductor is made of the same metal as the phase conductors. If this is not so, the cross-sectional area of the protective grounding conductor must be determined in a manner that produces a conductance equivalent to that which results from the application of this table.

The cross-sectional area of each protective grounding conductor that is not a part of the mains cable or the cable enclosure, must be a minimum of:

- 2.5 mm² if there is mechanical protection, and
- 4 mm² if there is not mechanical protection. If you have cord-connected equipment, make sure that the protective grounding conductor in the cord is the last conductor to be interrupted, if the strain-relief mechanism breaks.

Obey the local regulations on the minimum size of the protective grounding conductor.

NOTE!

Because there are high capacitive currents in the AC drive, it is possible that the fault current protective switches do not operate correctly.

If you use a fault protection relay, it must be of at least type B, preferably B+ (according to EN 50178), with a trip level of 300 mA. This is for fire protection, not for touch protection in grounded systems.



The earth fault protection inside the AC drive protects only the AC drive itself against earth faults in the motor or the motor cable. It is not intended for personal safety.



Do not do voltage withstand tests on the AC drive. The manufacturer has already done the tests. Doing voltage withstand tests can cause damage to the drive.

1.5 RUNNING THE MOTOR

Motor run check list



Before you start the motor, check that it is mounted properly and make sure that the machine connected to the motor allows the motor to be started.



Set the maximum motor speed (frequency) on the AC drive according to the motor and the machine connected to it.



Before reversing the motor make sure that this can be done safely.



Make sure that no power correction capacitors are connected to the motor cable.



Make sure that the motor terminals are not connected to mains potential.



Before you use the VACON[®] NX Liquid-Cooled AC drive to control the motor, make sure that liquid-cooling system functions properly.

NOTE! You can download the English and French product manuals with applicable safety, warning and caution information from <http://drives.danfoss.com/knowledge-center/technical-documentation/>.

REMARQUE Vous pouvez télécharger les versions anglaise et française des manuels produit contenant l'ensemble des informations de sécurité, avertissements et mises en garde applicables sur le site <http://drives.danfoss.com/knowledge-center/technical-documentation/>.

2. EU DIRECTIVE

2.1 CE MARKING

The CE marking on the product guarantees the free movement of the product within the EEA (European Economic Area).

VACON[®] NX AC drives carry the CE label as a proof of compliance with the Low Voltage Directive and the Electro Magnetic Compatibility Directive (EMC). The company SGS FIMKO has acted as the Competent Body.

2.2 EMC DIRECTIVE

2.2.1 GENERAL

The EMC Directive provides that the electrical apparatus must not excessively disturb the environment it is used in, and, on the other hand, it must have an adequate level of immunity toward other disturbances from the same environment.

The compliance of VACON[®] NX Liquid-Cooled AC drives with the EMC directive is verified with Technical Construction Files (TCF) checked and approved by SGS FIMKO, which is a Competent Body. The Technical Construction Files are used to authenticate the conformity of VACON[®] AC drives with the Directive because such a large-sized product family is impossible to be tested in a laboratory environment and because the combinations of installation vary greatly.

2.2.2 TECHNICAL CRITERIA

Our basic idea was to develop a range of AC drives offering the best possible usability and cost-efficiency. EMC compliance was a major consideration from the outset of the design.

VACON[®] NX Liquid-Cooled AC drives are marketed throughout the world, a fact which makes the EMC requirements of customers different. As far as the immunity is concerned, all VACON[®] NX Liquid-Cooled AC drives are designed to fulfil even the strictest requirements.

2.2.3 VACON[®] AC DRIVE EMC CLASSIFICATION

VACON[®] NX Liquid-Cooled AC drive and inverter modules delivered from factory fulfil all EMC immunity requirements (standard EN 61800-3).

The basic liquid cooled modules do not have any inherent emission filtering. If filtering is needed and a certain EMC emission level is required, external RFI filters must be used.

Class N:

The VACON[®] NX Liquid-Cooled drives of this class do not provide EMC emission protection. This kind of drives are mounted in enclosures. External EMC filtering is usually required to fulfil the EMC emission requirements.

Class T:

The T-class AC drives have a smaller earth leakage current and are intended to be used with IT supplies only. If they are used with other supplies no EMC requirements are complied with.

Warning: This is a product of the restricted sales distribution class according to IEC 61800-3. In a domestic environment this product may cause radio interference in which case the user may be required to take adequate measures.

2.2.4 EXPLANATIONS OF VOLTAGE CLASSES

NX_5 = 380 - 500 VAC drives -> DC link voltage = 465 - 800 VDC

NX_6 = 525 - 690 VAC drives -> DC link voltage = 640 - 1100 VDC

NX_8 = 525 - 690 VAC drives -> DC link voltage = 640 - 1200 VDC

2.2.4.1 IT networks

The grounding of input capacitors made by default with the grounding screw at terminal X41 of the bus board in all drives is imperative in all variations of TN/TT networks. Should a drive originally purchased for TN/TT networks be used in an IT network, the screw at X41 must be removed. It is strongly recommended that this be done by Danfoss personnel. Ask you local distributor for more information.

2.2.5 MANUFACTURER'S DECLARATION OF CONFORMITY

The following pages present the Manufacturer's Declarations of Conformity assuring the compliance of VACON® AC drives with the EMC-directives.



Danfoss A/S

DK-6430 Nordborg
Denmark
CVR nr.: 20 16 57 15

Telephone: +45 7488 2222
Fax: +45 7449 0949

EU DECLARATION OF CONFORMITY

Danfoss A/S

Vacon Ltd

declares under our sole responsibility that the

Product(s) VACON® NX Liquid-Cooled AC drive



Type(s) VACON® NXP 0016 5... to 4140 5
VACON® NXP 0170 6... to 3100 6
VACON® NXP 0170 8... to 3100 8
VACON® NXA 0016 5... to 4140 5
VACON® NXA 0170 6... to 3100 6
VACON® NXA 0170 8... to 3100 8
VACON® NXB 0016 5... to 4140 5
VACON® NXB 0170 6... to 3100 6
VACON® NXB 0170 8... to 3100 8
VACON® NXN 2000 6

Covered by this declaration is in conformity with the following directive(s), standard(s) or other normative document(s), provided that the product is used in accordance with our instructions.

Safety: EN 61800-5-1:2007
EN 60204-1:2006+A1:2009 (as relevant)
EMC: EN 61800-3:2004+A1:2012 (only immunity)

and conforms to the relevant safety provisions of Low Voltage Directive 2006/95/EC (until April 19th, 2016), 2014/35/EU (from April 20th, 2016) and EMC Directive 2004/108/EC (until April 19th, 2016), 2014/30/EU (from April 20th, 2016).

The year the CE marking was affixed: 2002

Date 15-04-2016	Issued by Signature  Name: Kimmo Syvänen Title: Director, Premium Drives	Date 15-04-2016	Approved by Signature  Name: Timo Kasi Title: VP, Design Center Finland and Italy
--------------------	--	--------------------	---

Danfoss only vouches for the correctness of the English version of this declaration. In the event of the declaration being translated into any other language, the translator concerned shall be liable for the correctness of the translation

3. RECEIPT OF DELIVERY

The standard delivery of VACON® NX Liquid-Cooled AC drives includes all or part of the following components:

- Power unit
- Control unit
- Main line connecting hoses and conduits (1.5 m) + aluminium adapters for Ch5-Ch74
- Tema 1300 series fast connectors for Ch3-Ch4
- Choke (not DC-fed inverters, type code I)
- Control unit mounting kit
- Optic fibre & cable set (1.5 m) for control unit; Optic sets in different lengths also available
- Optic fibre cable set for 2*CH64/CH74: 1.8 m/11 fibres (Power module 1) and 3.8 m/8 fibres (Power module 2)

VACON® NX Liquid-Cooled AC drives have undergone scrupulous tests and quality checks at the factory before they are delivered to the customer. However, after unpacking the product, check that no signs of transport damages are to be found on the product and that the delivery is complete (compare the type designation of the product to the code).

Should the drive have been damaged during the shipping, contact primarily the cargo insurance company or the carrier.

If the delivery does not correspond to your order, contact the supplier immediately.

3.1 TYPE DESIGNATION CODE

The type designation code for the VACON® NX Liquid-Cooled drives is presented below.

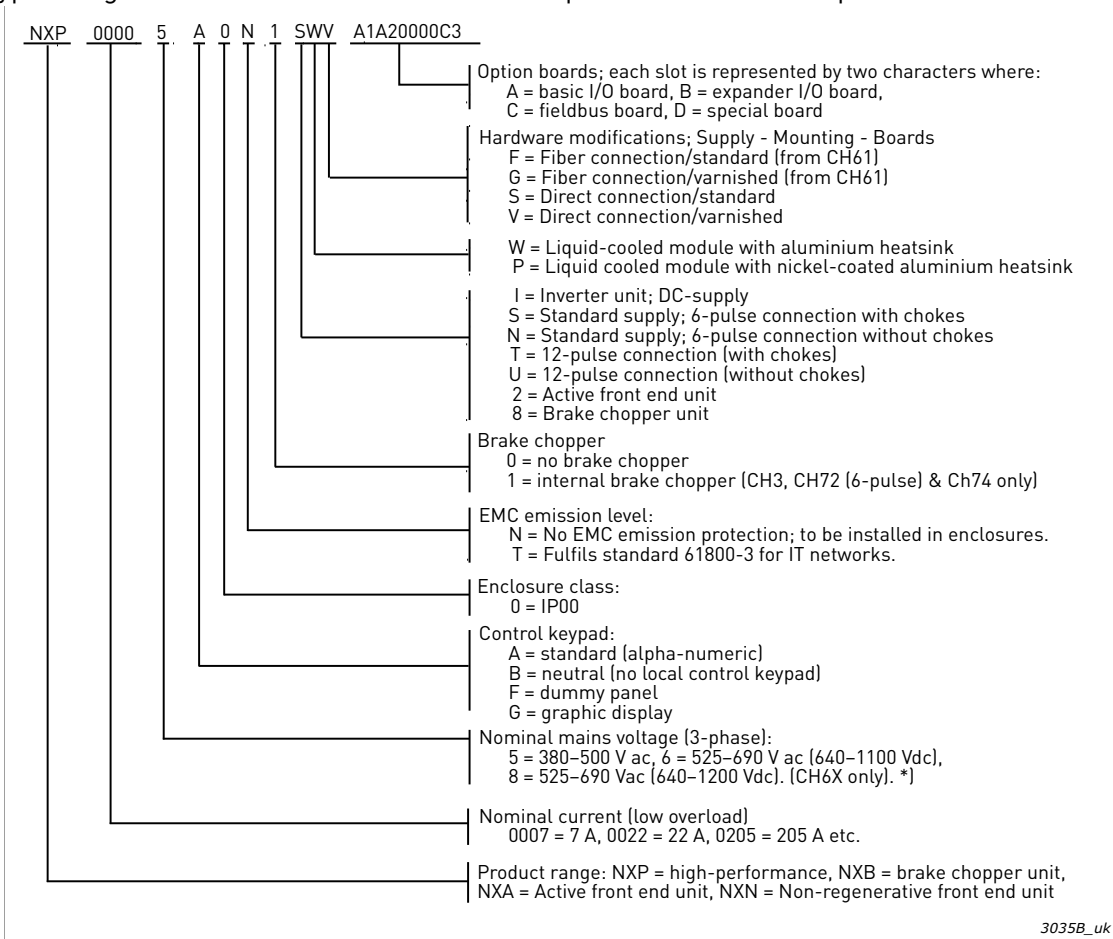

3035B_uk

*) Note, the control unit of NX_8 (voltage class 8) drives need to be supplied with a external 24 Vdc power source.

3.2 STORAGE AND SHIPPING

If the AC drive is to be kept in store before use make sure that the ambient conditions are acceptable:

- Storing temperature –40...+70 °C (no cooling liquid inside cooling element allowed below 0 °C)
- Relative humidity <96%, no condensation

If the storage time exceeds 12 months the electrolytic DC capacitors need to be charged with caution. Therefore, such a long storage time is not recommended. See Chapter 9.3 and the VACON® NX Liquid-Cooled Drives Service Manual for instructions on charging. See also Chapter 3.3.

Warning: Always remove all cooling agent from the cooling element(s) before shipping to avoid damage caused by freezing.

3.3 MAINTENANCE

In case the AC drive is used in conditions with temperatures below the freezing point and the liquid used for cooling is likely to freeze, be sure to empty the cooling element if the AC drive must be moved or if it is taken out of use for a longer time. See also Chapter 3.2.

It may also be necessary to clean up the coolant ducts in the cooling element. Contact the factory for more information.

The instructions for the cooling system provided by its manufacturer must be followed.

NOTE! The content of the maintenance and intervals may vary depending on ambient conditions, assembly and application.

Table 2. VACON® NX Liquid-Cooled AC drive maintenance program, general

Inspection target	Inspection intervals	Service schedule	Proactive maintenance actions
Conditions of installation environment	1 year	1 year	Check that installation and environment conditions are within manufacturer's specification, in respect, for example, heat, dust, moisture, vibration. Take corrective actions based on findings.
Cleaning	1 year	1 year	If needed, clean the product with an antistatic vacuum cleaner.
Cleanliness of cooling tunnel	1 year	1 year	Check/evaluate the cleanliness of the cooling tunnel for air cooled drives. Cleaning if necessary.
Air filters	3 months	<ul style="list-style-type: none"> • 3 months in demanding environment • 1 year in typical environment 	NOTE! VACON® NX Liquid-Cooled AC drives do not include air filter. They may be included in the enclosure solution. The inspection and replacement intervals of filters depend on the environment. Replace at least once a year.
Sealings	1 year	Based on inspection	Check the sealings for IP21 or IP54 AC drives. Check visually the cable bushing. Take corrective actions based on findings.

Table 2. VACON® NX Liquid-Cooled AC drive maintenance program, general

Inspection target	Inspection intervals	Service schedule	Proactive maintenance actions
Main DC cooling fans and internal cooling fans for electronics	1 year	5 year	Replace parts according to service schedule or based on maintenance report recommendation.
DC-link capacitors	1 year	<ul style="list-style-type: none"> • 8 years in demanding environment or heavy load • 12 years in typical environment or normal load 	The expected life time of the capacitor is determined based on load and the temperature of the environment. Replace parts according to service schedule.
Product upgrades	1 year	1 year	Manufacturer offers product upgrades.
Printed circuit boards	1 year	12 years in typical environment	The printed circuit boards to be checked for contamination and possible corrosion. In case of contamination or corrosion printed circuit boards to be changed.
Recommended reforming interval for electrolytic DC-link capacitors (spare parts and products in storage)	1 year	1 year	Reforming must be done once a year for products and spare part capacitors in storage. Ask instructions from your local distributor.

Table 3. VACON® Liquid-Cooled AC drive maintenance program, liquid cooling system

Inspection target	Inspection intervals	Service schedule	Proactive maintenance actions
Coolant inhibitor	1 year	2 years	Add inhibitor according to instructions or analyze the coolant and add inhibitor based on result.
Coolant	2 years	6 years	Check and change coolant according to service schedule.
VACON® NX Liquid-Cooled drive coolant flow	1 year	Based on inspection	Check pressure, flow and temperature of the system. Compare to previous measurement. Temperature alarm or trip indicates that AC drive warms up and the flow is too low. Cleaning of heatsink if necessary, Ask instructions from your local distributor.

Table 3. VACON® Liquid-Cooled AC drive maintenance program, liquid cooling system

Inspection target	Inspection intervals	Service schedule	Proactive maintenance actions
Coolant leakage	3 months	Based on inspection	Open the cubicle doors and check that there are no visible leaks on cooling unit or coolant manifold connections. If you find a leak, shut down the unit and repair the leak.

Table 4. VACON® Liquid-Cooled AC drive maintenance program, cabinet, cabling and connections

Inspection target	Inspection intervals	Service schedule	Proactive maintenance actions
Cabinet, auxiliary devices (contactors, switches, relays, push buttons, indicators, etc.)	1 year	According to manufacturer information	Replace parts according to service schedule or based on maintenance report recommendation.
Sealings	1 year	Based on inspection	Check cabinet and drive sealings. Check visually cable bushing. Corrective actions based on findings.
Visual inspection of cablings	1 year	1 year	Visual inspection for possible damages and so on, due to, for example, vibration. Actions based on inspection.
Tightness of connections	1 year	1 year	Check and tighten the cable and wire connections.
Radiator cooling fans and control compartment fans	1 year	5 years	Check the operation of the fans and measure the radiator fan capacitor every 2 years. Replace parts according to service schedule or based on maintenance report recommendation.

3.4 WARRANTY

Only manufacturing defects are covered by the warranty. The manufacturer assumes no responsibility for damages caused during or resulting from transport, receipt of the delivery, installation, commissioning or use.

The manufacturer shall in no event and under no circumstances be held responsible for damages and failures resulting from misuse, wrong installation, unacceptable ambient temperature, running motor with lower coolant flow than minimum flow, condensation, dust, corrosive substances or operation outside the rated specifications.

Neither can the manufacturer be held responsible for consequential damages.

NOTE! VACON® NX Liquid-Cooled drives must not be run with the liquid cooling system disconnected. Furthermore, the requirements of the liquid cooling specifications, e.g. minimum flow rate (see Chapter 5.2 and Table 15) must be satisfied. Ignoring this will render the warranty null and void.

NOTE! VACON® Liquid-Cooled NX_8 inverter unit must be equipped with a du/dt- or sine-filter. The warranty is void in case filter are not used with these units.

The Manufacturer's time of warranty, if not otherwise agreed, is 18 months from the delivery or 12 months from the commissioning whichever expires first.

The local distributor may grant a warranty time different from the above. This warranty time shall be specified in the distributor's sales and warranty terms. Vacon Ltd assumes no responsibility for any other warranties than that granted by Vacon itself.

In all matters concerning the warranty, contact first your distributor.

4. TECHNICAL DATA

4.1 INTRODUCTION

The VACON® NX_W Liquid-Cooled product range consists of active front ends, inverters, brake choppers and AC drives. Figure 1 & Figure 2 presents the block diagram of the VACON® NX Liquid-Cooled inverter and AC drive. Mechanically, the product consists of two units, the Power Unit and the Control Unit. The power unit can contain one to six modules (cooling plates), depending on the drive size. Instead of air, VACON® NX Liquid-Cooled inverters and AC drives use liquid for cooling. A charging circuit is embodied in the AC drives but not in active front ends, inverters or brake choppers.

An external three-phase AC-choke (1) at the mains input together with the DC-link capacitor (2) form an LC-filter. In AC drives, the LC-filter together with the diode bridge produce the DC-voltage supply to the IGBT Inverter Bridge (3) block. The AC-choke also functions as a filter against High Frequency disturbances from the mains as well as against those caused by the AC drive to the mains. In addition, it enhances the waveform of the input current to the AC drive. In chasses with multiple parallel line-rectifiers (CH74) AC-chokes are required to balance the line current between the rectifiers.

The power drawn by the AC drive from the mains is mostly active power.

The IGBT Inverter Bridge produces a symmetrical, 3-phase Pulse Width Modulated AC-voltage to the motor.

The Motor and Application Control Block is based on microprocessor software. The microprocessor controls the motor basing on the information it receives through measurements, parameter settings, control I/O and control keypad. The motor and application control block controls the motor control ASIC which, in turn, calculates the IGBT positions. Gate drivers amplify these signals for driving the IGBT inverter bridge.

The control keypad constitutes a link between the user and the AC drive. The control keypad is used for parameter setting, reading status data and giving control commands. It is detachable and can be operated externally and connected via a cable to the AC drive. Instead of the control keypad, a PC can also be used to control the AC drive if connected through a similar cable (± 12 V).

You can have your AC drive equipped with a control I/O board which is either isolated (OPT-A8) or not isolated (OPT-A1) from the frame. Optional I/O expander boards that increase the number of inputs and outputs to be used are also available. For closer information, contact the Manufacturer or your nearest distributor.

The basic control interface and the parameters (the Basic Application) are easy to use. If a more versatile interface or parameters are required, a more suitable application can be chosen from the "All in One" Application Package. See VACON® NX All in One Application Manual for more information on the different applications.

An internal brake chopper is available as standard for chassis CH3. For Ch72 (only 6-pulse) and Ch74, it is available as internal option while in all other sizes the brake chopper is available as option and installed externally. The standard product does not include a brake resistor. It should be acquired separately.

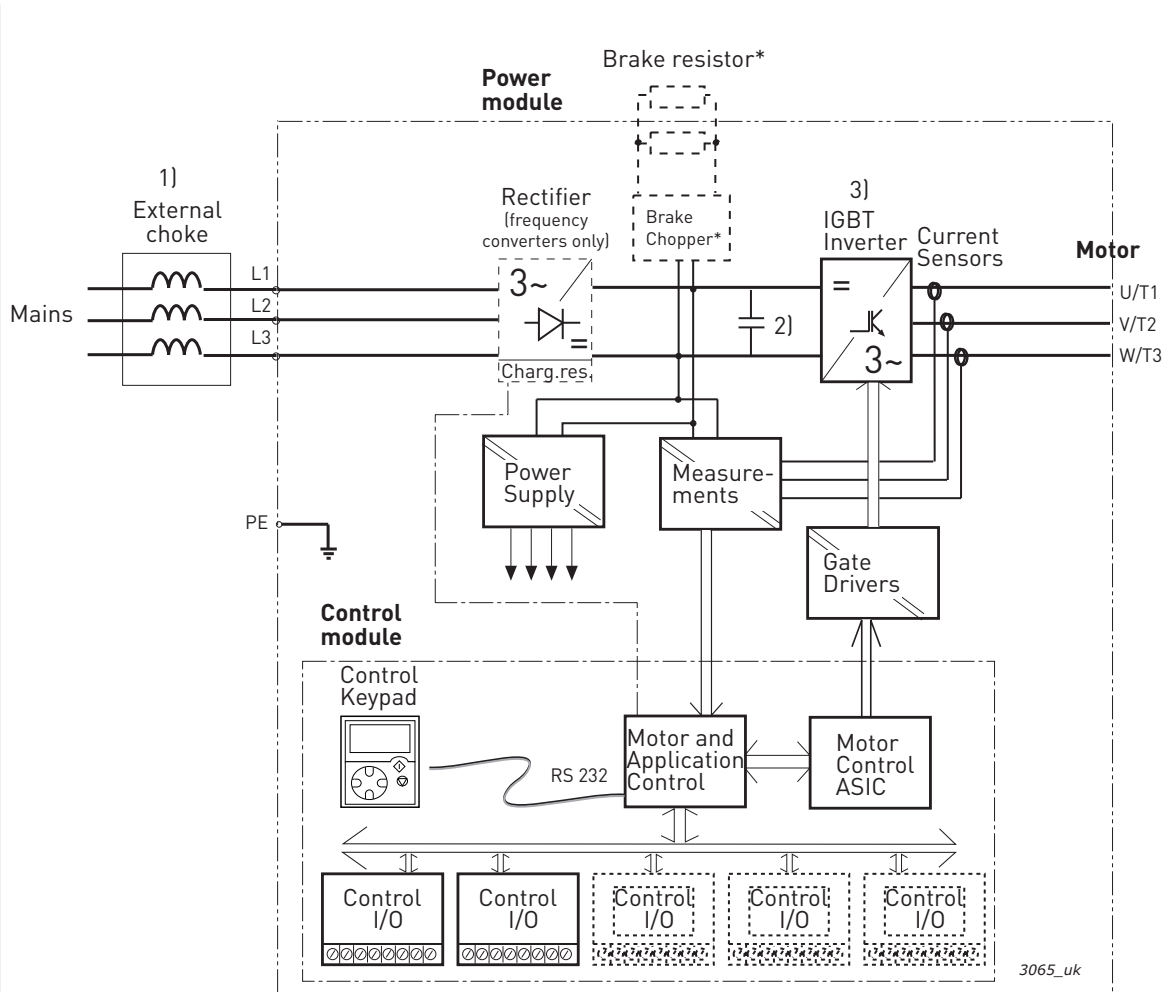

*Brake resistor is available for all sizes (CH3 to CH7). An internal brake chopper belongs to standard equipment in sizes CH3. For CH72 (only 6-pulse) and CH74, it is available as internal option while in all other sizes it is optional but installed externally.

Figure 1. VACON® NX Liquid-Cooled AC drive principal block diagram

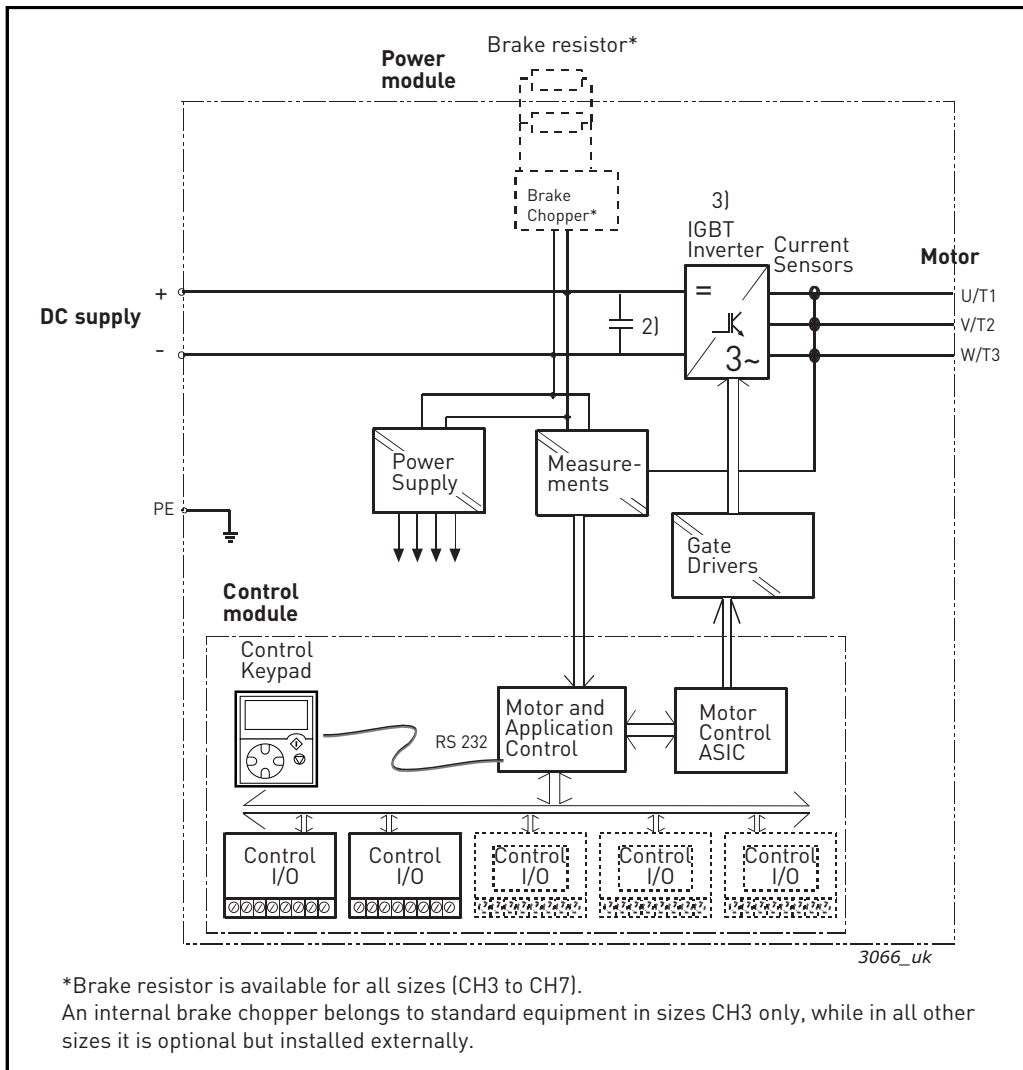

Figure 2. VACON® NX Liquid-Cooled inverter principal block diagram

4.2 POWER RATINGS

VACON® Liquid-Cooled product range consists of both AC drives (AC input, AC output) and inverter units (DC input, AC output). The following tables present the drive output values for both and an indication of motor shaft power at I_{th} and I_L at different mains voltages as well as the drive losses and mechanical sizes. The power achieved is given as per the supply voltage.

4.2.1 AC DRIVES

4.2.1.1 VACON® NX Liquid-Cooled AC drive – Mains voltage 400–500 VAC

Table 5. Power ratings of VACON® NX Liquid-Cooled AC drive (6-pulse), supply voltage 400-500 VAC

Mains voltage 400-500 VAC, 50/60 Hz, 3~, 6-pulse drives							
AC drive type	Drive output					Power loss c/a/T*) [kW]	Chassis
	Current			Motor output power			
	Thermal I_{th} [A]	Rated cont. I_L [A]	Rated contin. I_H [A]	Optimum motor at I_{th} (400 V) [kW]	Optimum motor at I_{th} (500 V) [kW]		
0016_5	16	15	11	7.5	11	0.4/0.2/0.6	CH3
0022_5	22	20	15	11	15	0.5/0.2/0.7	CH3
0031_5	31	28	21	15	18.5	0.7/0.2/0.9	CH3
0038_5	38	35	25	18.5	22	0.8/0.2/1.0	CH3
0045_5	45	41	30	22	30	1.0/0.3/1.3	CH3
0061_5	61	55	41	30	37	1.3/0.3/1.5	CH3
0072_5	72	65	48	37	45	1.2/0.3/1.5	CH4
0087_5	87	79	58	45	55	1.5/0.3/1.8	CH4
0105_5	105	95	70	55	75	1.8/0.3/2.1	CH4
0140_5	140	127	93	75	90	2.3/0.3/2.6	CH4
0168_5	168	153	112	90	110	4.0/0.4/4.4	CH5
0205_5	205	186	137	110	132	5.0/0.5/5.5	CH5
0261_5	261	237	174	132	160	6.0/0.5/6.5	CH5
0300_5	300	273	200	160	200	4.5/0.5/5.0	CH61
0385_5	385	350	257	200	250	6.0/0.5/6.5	CH61
0460_5	460	418	307	250	315	6.5/0.5/7.0	CH72
0520_5	520	473	347	250	355	7.5/0.6/8.1	CH72
0590_5	590	536	393	315	400	9.0/0.7/9.7	CH72
0650_5	650	591	433	355	450	10.0/0.7/10.7	CH72
0730_5	730	664	487	400	500	12.0/0.8/12.8	CH72
0820_5	820	745	547	450	560	12.5/0.8/13.3	CH63
0920_5	920	836	613	500	600	14.4/0.9/15.3	CH63
1030_5	1030	936	687	560	700	16.5/1.0/17.5	CH63
1150_5	1150	1045	766	600	750	18.5/1.2/19.7	CH63
1370_5	1370	1245	913	700	900	19.0/1.2/20.2	CH74
1640_5	1640	1491	1093	900	1100	24.0/1.4/25.4	CH74
2060_5	2060	1873	1373	1100	1400	32.5/1.8/34.3	CH74
2300_5	2300	2091	1533	1250	1500	36.3/2.0/38.3	CH74

Table 5. Power ratings of VACON® NX Liquid-Cooled AC drive (6-pulse), supply voltage 400-500 VAC

Mains voltage 400-500 VAC, 50/60 Hz, 3~, 6-pulse drives							
2470_5	2470	2245	1647	1300	1600	38.8/2.2/41.0	2*CH74
2950_5	2950	2681	1967	1550	1950	46.3/2.6/48.9	2*CH74
3710_5	3710	3372	2473	1950	2450	58.2/3.0/61.2	2*CH74
4140_5	4140	3763	2760	2150	2700	65.0/3.6/68.6	2*CH74

Table 6. Power ratings of VACON® NX Liquid-Cooled AC drive (12-pulse), supply voltage 400-500 VAC

Mains voltage 400-500 VAC, 50/60 Hz, 3~, 12-pulse drives							
AC drive type	Drive output					Power loss c/a/T*) [kW]	Chassis
	Current			Motor output power			
	Thermal I _{th} [A]	Rated cont. I _L [A]	Rated contin. I _H [A]	Optimum motor at I _{th} (400 V) [kW]	Optimum motor at I _{th} (500 V) [kW]		
0460_5	460	418	307	250	315	6.5/0.5/7.0	CH72
0520_5	520	473	347	250	355	7.5/0.6/8.1	CH72
0590_5	590	536	393	315	400	9.0/0.7/9.7	CH72
0650_5	650	591	433	355	400	10.0/0.7/10.7	CH72
0730_5	730	664	487	400	450	12.0/0.8/12.8	CH72
1370_5	1370	1245	913	700	900	19.0/1.2/20.2	CH74
1640_5	1640	1491	1093	850	1050	24.0/1.4/25.4	CH74
2060_5	2060	1873	1373	1050	1350	32.5/1.8/34.3	CH74
2470_5	2470	2245	1647	1300	1600	38.8/2.2/41.0	2*CH74
2950_5	2950	2681	1967	1550	1950	46.3/2.6/48.9	2*CH74
3710_5	3710	3372	2473	1950	2450	58.2/3.0/61.2	2*CH74
4140_5	4140	3763	2760	2150	2700	65.0/3.6/68.6	2*CH74

I_{th} = Thermal maximum continuous RMS current. Dimensioning can be done according to this current if the process does not require any overloadability or the process does not include any load variation or margin for overloadability.

I_L = Low overloadability current. Allows +10% load variation. 10% exceeding can be continuous.

I_H = High overloadability current. Allows +50% load variation. 50% exceeding can be continuous.

All values with cosφ = 0.83 and efficiency = 97%.

*) c = power loss into coolant; a = power loss into air; T = total power loss; power losses of input chokes not included. All power losses obtained using max. supply voltage, I_{th} and switching frequency of 3.6 kHz and Closed Loop control mode. All power losses are worst case losses.

If some other mains voltage is used, apply the formula $P = \sqrt{3} \times U_n \times I_n \times \cos\phi \times \text{eff}\%$ to calculate the VACON® NX Liquid-Cooled drive output power.

The enclosure class for all VACON® NX Liquid-Cooled AC drives is IP00.

If the motor is continuously (besides start and stop ramps) run at frequencies below 5 Hz, pay attention to the drive dimensioning for low frequencies, i.e. maximum I_H = 0.66*I_{th} or choose drive according to I_H. It is recommended to check the rating with your nearest distributor.

Drive overrating may also be necessary if the process requires high starting torque.

Table 7. Internal brake chopper unit (BCU) ratings, braking voltage 640–800 VDC

Internal brake chopper ratings, braking voltage 640-800 Vdc						
AC drive type	Loadability	Braking capacity at 600 Vdc		Braking capacity at 800 Vdc		Chassis
	Rated min resistance [Ω]	Rated cont. braking power [kW]	BCU rated cont. braking current, I _{br} [A]	Rated cont. braking power R at 800VDC [kW]	BCU rated cont. braking current, I _{br} [A]	
NX_460 5 ¹⁾	1.3	276	461	492	615	CH72
NX_520 5 ¹⁾	1.3	276	461	492	615	CH72
NX_590 5 ¹⁾	1.3	276	461	492	615	CH72
NX_650 5 ¹⁾	1.3	276	461	492	615	CH72
NX_730 5 ¹⁾	1.3	276	461	492	615	CH72
NX_1370 5	1.3	276	461	492	615	CH74
NX_1640 5	1.3	276	461	492	615	CH74
NX_2060 5	1.3	276	461	492	615	CH74
NX_2300 5	1.3	276	461	492	615	CH74

NOTE! Braking power: $P_{brake} = U_{brake}^2 / R_{brake}$

NOTE! Braking DC current: $I_{in_max} = P_{brake_max} / U_{brake}$

¹⁾ Only 6 pulse drives

The internal brake chopper can also be used in motor application where 2...4 x Ch7x drives are used for a single motor, but in this case the DC connections of the power modules must be connected together. The break choppers are working independently of each other and because of this the DC connections must be connected together otherwise there can be unbalance between the power modules.

4.2.1.2 VACON® NX Liquid-Cooled AC drive – Mains voltage 525–690 VAC

Table 8. Power ratings of VACON® NX Liquid-Cooled AC drive (6-pulse), supply voltage 525–690 VAC

Mains voltage 525-690 VAC, 50/60 Hz, 3~, 6-pulse drives							
AC drive type	Drive output					Power loss c/a/T* ¹ [kW]	Chassis
	Current			Motor output power			
	Thermal I _{th} [A]	Rated contin. I _L [A]	Rated contin. I _H [A]	Optimum motor at I _{th} (525V) [kW]	Optimum motor at I _{th} (690V) [kW]		
0170_6	170	155	113	110	160	4.0/0.2/4.2	CH61
0208_6	208	189	139	132	200	4.8/0.3/5.1	CH61
0261_6	261	237	174	160	250	6.3/0.3/6.6	CH61
0325_6	325	295	217	200	300	7.2/0.4/7.6	CH72
0385_6	385	350	257	250	355	8.5/0.5/9.0	CH72
0416_6	416	378	277	250	355	9.1/0.5/9.6	CH72
0460_6	460	418	307	300	400	10.0/0.5/10.5	CH72
0502_6	502	456	335	355	450	11.2/0.6/11.8	CH72
0590_6	590	536	393	400	560	12.4/0.7/13.1	CH63
0650_6	650	591	433	450	600	14.2/0.8/15.0	CH63
0750_6	750	682	500	500	700	16.4/0.9/17.3	CH63
0820_6	820	745	547	560	800	17.3/1.0/18.3	CH74
0920_6	920	836	613	650	850	19.4/1.1/20.5	CH74
1030_6	1030	936	687	700	1000	21.6/1.2/22.8	CH74
1180_6	1180	1073	787	800	1100	25.0/1.3/26.3	CH74
1300_6	1300	1182	867	900	1200	27.3/1.5/28.8	CH74
1500_6	1500	1364	1000	1050	1400	32.1/1.7/33.8	CH74
1700_6	1700	1545	1133	1150	1550	36.5/1.9/38.4	CH74
1850_6	1850	1682	1233	1250	1650	39.0/2.0/41.0	2*CH74
2120_6	2120	1927	1413	1450	1900	44.9/2.4/47.3	2*CH74
2340_6	2340	2127	1560	1600	2100	49.2/2.6/51.8	2*CH74
2700_6	2700	2455	1800	1850	2450	57.7/3.1/60.8	2*CH74
3100_6	3100	2818	2066	2150	2800	65.7/3.4/69.1	2*CH74

Table 9. Power ratings of VACON® NX Liquid-Cooled AC drive (12-pulse), supply voltage 525–690 VAC

Mains voltage 525-690 VAC, 50/60 Hz, 3~, 12-pulse drives							
AC drive type	Drive output					Power loss c/a/T* ¹ [kW]	Chassis
	Current			Motor output power			
	Thermal I _{th} [A]	Rated contin. I _L [A]	Rated contin. I _H [A]	Optimum motor at I _{th} (525V) [kW]	Optimum motor at I _{th} (690V) [kW]		
0325_6	325	295	217	200	250	7.2/0.4/7.6	CH72
0385_6	385	350	257	250	355	8.5/0.5/9.0	CH72

Table 9. Power ratings of VACON® NX Liquid-Cooled AC drive (12-pulse), supply voltage 525–690 VAC

Mains voltage 525-690 VAC, 50/60 Hz, 3~, 12-pulse drives							
0416_6	416	378	277	250	355	9.1/0.5/9.6	CH72
0460_6	460	418	307	315	400	10.0/0.5/10.5	CH72
0502_6	502	456	335	355	450	11.2/0.6/11.8	CH72
0820_6	820	745	547	600	750	17.3/1.0/18.3	CH74
0920_6	920	836	613	650	850	19.4/1.1/20.5	CH74
1030_6	1030	936	687	750	950	21.6/1.2/22.8	CH74
1180_6	1180	1073	787	800	1100	25.0/1.3/26.3	CH74
1300_6	1300	1182	867	950	1200	27.3/1.5/28.8	CH74
1500_6	1500	1364	1000	1050	1400	32.1/1.7/33.8	CH74
1700_6	1700	1545	1133	1150	1550	36.5/1.9/38.4	Ch74
1850_6	1850	1682	1233	1250	1650	39.0/2.0/41.0	2*CH74
2120_6	2120	1927	1413	1450	1900	44.9/2.4/47.3	2*CH74
2340_6	2340	2127	1560	1600	2100	49.2/2.6/51.8	2*CH74
2700_6	2700	2455	1800	1850	2450	57.7/3.1/60.8	2*CH74
3100_6	3100	2818	2067	2150	2800	65.7/3.4/69.1	2*CH74

I_{th} = Thermal maximum continuous RMS current. Dimensioning can be done according to this current if the process does not require any overloadability or the process does not include any load variation.

I_L = Low overloadability current. Allows +10% load variation. 10% exceeding can be continuous.

I_H = High overloadability current. Allows +50% load variation. 50% exceeding can be continuous.

All values with $\cos\phi = 0.83$ and efficiency = 97%.

*) c = power loss into coolant; a = power loss into air; T = total power loss; power losses of input chokes not included. All power losses obtained using max. supply voltage, I_{th} and switching frequency of 3.6 kHz and Closed Loop control mode. All power losses are worst case losses.

If some other mains voltage is used, apply the formula $P = \sqrt{3} \times U_n \times I_n \times \cos\phi \times \text{eff}\%$ to calculate the VACON® NX Liquid-Cooled drive output power.

The enclosure class for all VACON® NX Liquid-Cooled AC drives is IP00.

If the motor is continuously (besides start and stop ramps) run at frequencies below 5 Hz, pay attention to the drive dimensioning for low frequencies, i.e. maximum $I_H = 0.66 \times I_{th}$ or choose drive according to I_H . It is recommended to check the rating with your nearest distributor.

Drive overrating may also be necessary if the process requires high starting torque.

Table 10. Internal brake chopper unit (BCU) ratings, braking voltage 840–1100 VDC

Internal brake chopper ratings, braking voltage 840-1100 Vdc						
AC drive Type	Loadability	Braking capacity at 840 Vdc		Braking capacity at 1100 Vdc		Chassis
	Rated min resistance [Ω]	Rated cont. braking power [kW]	BCU rated cont. braking current, I_{br} [A]	Rated cont. braking power [kW]	BCU rated cont. braking current, I_{br} [A]	
NX_325 6 ¹⁾	2.8	252	300	432	392	Ch72
NX_385 6 ¹⁾	2.8	252	300	432	392	Ch72
NX_416 6 ¹⁾	2.8	252	300	432	392	Ch72

Table 10. Internal brake chopper unit (BCU) ratings, braking voltage 840—1100 VDC

Internal brake chopper ratings, braking voltage 840-1100 Vdc						
NX_460 6 ¹⁾	2.8	252	300	432	392	Ch72
NX_502 6 ¹⁾	2.8	252	300	432	392	Ch72
NX_820 6	2.8	252	300	432	392	Ch74
NX_920 6	2.8	252	300	432	392	Ch74
NX_1030 6	2.8	252	300	432	392	Ch74
NX_1180 6	2.8	252	300	432	392	Ch74
NX_1300 6	2.8	252	300	432	392	Ch74
NX_1500 6	2.8	252	300	432	392	Ch74
NX_1700 6	2.8	252	300	432	392	Ch74

NOTE! Braking power: $P_{\text{brake}} = U_{\text{brake}}^2 / R_{\text{brake}}$

NOTE! Braking DC current: $I_{\text{in_max}} = P_{\text{brake_max}} / U_{\text{brake}}$

¹⁾ Only 6 pulse drives

The internal brake chopper can also be used in motor application where 2...4 x Ch7x drives are used for a single motor, but in this case the DC connections of the power modules must be connected together. The break choppers are working independently of each other and because of this the DC connections must be connected together otherwise there can be unbalance between the power modules.

4.2.2 INVERTER UNITS

4.2.2.1 VACON® NX Liquid-Cooled Inverter Unit – Mains voltage 465–800 VDC

Table 11. Power ratings of VACON® NX Liquid-Cooled inverter unit, supply voltage 540–675 VDC

Mains voltage 465-800 VDC							
AC drive type	Drive output					Power loss c/a/T* ¹ [kW]	Chassis
	Current			Motor output power			
	Thermal I _{th} [A]	Rated cont. I _L [A]	Rated cont. I _H [A]	Optimum motor at I _{th} (540 VDC) [kW]	Optimum motor at I _{th} (675 VDC) [kW]		
0016_5	16	15	11	7.5	11	0.4/0.2/0.6	CH3
0022_5	22	20	15	11	15	0.5/0.2/0.7	CH3
0031_5	31	28	21	15	18.5	0.7/0.2/0.9	CH3
0038_5	38	35	25	18.5	22	0.8/0.2/1.0	CH3
0045_5	45	41	30	22	30	1.0/0.3/1.3	CH3
0061_5	61	55	41	30	37	1.3/0.3/1.5	CH3
0072_5	72	65	48	37	45	1.2/0.3/1.5	CH4
0087_5	87	79	58	45	55	1.5/0.3/1.8	CH4
0105_5	105	95	70	55	75	1.8/0.3/2.1	CH4
0140_5	140	127	93	75	90	2.3/0.3/2.6	CH4
0168_5	168	153	112	90	110	2.5/0.3/2.8	CH5
0205_5	205	186	137	110	132	3.0/0.4/3.4	CH5
0261_5	261	237	174	132	160	4.0/0.4/4.4	CH5
0300_5	300	273	200	160	200	4.5/0.4/4.9	CH61
0385_5	385	350	257	200	250	5.5/0.5/6.0	CH61
0460_5	460	418	307	250	315	5.5/0.5/6.0	CH62
0520_5	520	473	347	250	355	6.5/0.5/7.0	CH62
0590_5	590	536	393	315	400	7.5/0.6/8.1	CH62
0650_5	650	591	433	355	450	8.5/0.6/9.1	CH62
0730_5	730	664	487	400	500	10.0/0.7/10.7	CH62
0820_5	820	745	547	450	560	12.5/0.8/13.3	CH63
0920_5	920	836	613	500	600	14.4/0.9/15.3	CH63
1030_5	1030	936	687	560	700	16.5/1.0/17.5	CH63
1150_5	1150	1045	766	600	750	18.4/1.1/19.5	CH63
1370_5	1370	1245	913	700	900	15.5/1.0/16.5	CH64
1640_5	1640	1491	1093	900	1100	19.5/1.2/20.7	CH64
2060_5	2060	1873	1373	1100	1400	26.5/1.5/28.0	CH64
2300_5	2300	2091	1533	1250	1500	29.6/1.7/31.3	CH64
2470_5	2470	2245	1647	1300	1600	36.0/2.0/38.0	2*CH64
2950_5	2950	2681	1967	1550	1950	39.0/2.4/41.4	2*CH64
3710_5	3710	3372	2473	1950	2450	48.0/2.7/50.7	2*CH64
4140_5	4140	3763	2760	2150	2700	53.0/3.0/56.0	2*CH64

I_{th} = Thermal maximum continuous RMS current. Dimensioning can be done according to this current if the process does not require any overloadability or the process does not include any load variation.

I_L = Low overloadability current. Allows +10% load variation. 10% exceeding can be continuous.

I_H = High overloadability current. Allows +50% load variation. 50% exceeding can be continuous.

All values with $\cos\phi = 0.83$ and efficiency = 97%.

*) c = power loss into coolant; a = power loss into air; T = total power loss.

All power losses obtained using max. supply voltage, I_{th} and switching frequency of 3.6 kHz and Closed Loop control mode. All power losses are worst case losses.

If some other mains voltage is used, apply the formula $DC P = (U_{DC}/1.35) * \sqrt{3} * I_n * \cos\phi * \text{eff}\%$ to calculate the VACON® NX Liquid-Cooled drive electrical output power.

If the motor is continuously (besides start and stop ramps) run at frequencies below 5 Hz, pay attention to the drive dimensioning for low frequencies, i.e. maximum $I_H = 0.66 * I_{th}$ or choose drive according to I_H . It is recommended to check the rating with your nearest distributor.

Drive overrating may also be necessary if the process requires high starting torque.

The voltage classes for the inverter units used in the tables above have been defined as follows:

Input 540 VDC = Rectified 400 VAC supply

Input 675 VDC = Rectified 500 VAC supply

The enclosure class of all inverter units is IP00.

4.2.2.2 VACON® NX Liquid-Cooled Inverter Unit – Mains voltage 640–1100 VDC

Table 12. Power ratings of VACON® NX Liquid-Cooled inverter unit, supply voltage 710–930 VDC

Mains voltage 640-1100 VDC*)							
Inverter type	Drive output					Power loss c/a/T*) [kW]	Chassis
	Current			Motor output power			
	Thermal I_{th} [A]	Rated cont. I_L [A]	Rated cont. I_H [A]	Optimum motor at I_{th} [710VDC] [kW]	Optimum motor at I_{th} [930VDC] [kW]		
0170_6	170	155	113	110	160	3.6/0.2/3.8	CH61
0208_6	208	189	139	132	200	4.3/0.3/4.6	CH61
0261_6	261	237	174	160	250	5.4/0.3/5.7	CH61
0325_6	325	295	217	200	300	6.5/0.3/6.8	CH62
0385_6	385	350	257	250	355	7.5/0.4/7.9	CH62
0416_6	416	378	277	250	355	8.0/0.4/8.4	CH62
0460_6	460	418	307	300	400	8.7/0.4/9.1	CH62
0502_6	502	456	335	355	450	9.8/0.5/10.3	CH62
0590_6	590	536	393	400	560	10.9/0.6/11.5	CH63
0650_6	650	591	433	450	600	12.4/0.7/13.1	CH63
0750_6	750	682	500	500	700	14.4/0.8/15.2	CH63
0820_6	820	745	547	560	800	15.4/0.8/16.2	CH64
0920_6	920	836	613	650	850	17.2/0.9/18.1	CH64
1030_6	1030	936	687	700	1000	19.0/1.0/20.0	CH64
1180_6	1180	1073	787	800	1100	21.0/1.1/22.1	CH64
1300_6	1300	1182	867	900	1200	24.0/1.3/25.3	CH64
1500_6	1500	1364	1000	1050	1400	28.0/1.5/29.5	CH64
1700_6	1700	1545	1133	1150	1550	32.1/1.7/33.8	CH64
1850_6	1850	1682	1233	1250	1650	34.2/1.8/36.0	2*CH64

Table 12. Power ratings of VACON® NX Liquid-Cooled inverter unit, supply voltage 710–930 VDC

Mains voltage 640-1100 VDC*)							
2120_6	2120	1927	1413	1450	1900	37.8/2.0/39.8	2*CH64
2340_6	2340	2127	1560	1600	2100	43.2/2.3/45.5	2*CH64
2700_6	2700	2455	1800	1850	2450	50.4/2.7/53.1	2*CH64
3100_6	3100	2818	2066	2150	2800	57.7/3.1/60.8	2*CH64

*) Mains voltage 640-1200 VDC for NX_8 inverter units

I_{th} = Thermal maximum continuous RMS current. Dimensioning can be done according to this current if the process does not require any overloadability or the process does not include any load variation.

I_L = Low overloadability current. Allows +10% load variation. 10% exceeding can be continuous.

I_H = High overloadability current. Allows +50% load variation. 50% exceeding can be continuous.

All values with $\cos\phi = 0.83$ and efficiency = 97%.

*) c = power loss into coolant; a = power loss into air; T = total power loss.

All power losses obtained using max. supply voltage, I_{th} and switching frequency of 3.6 kHz and Closed Loop control mode. All power losses are worst case losses.

If some other mains voltage is used, apply the formula $DC P = (U_{DC}/1.35) * \sqrt{3} * I_n * \cos\phi * \text{eff}\%$ to calculate the VACON® NX Liquid-Cooled drive output power.

The voltage classes for the inverter units used in the tables above have been defined as follows:

Input 710 VDC = Rectified 525 VAC supply

Input 930 VDC = Rectified 690 VAC supply

The enclosure class of all inverter units is IP00.

If the motor is continuously (besides start and stop ramps) run at frequencies below 5 Hz, pay attention to the drive dimensioning for low frequencies, i.e. maximum $I_H = 0.66 * I_{th}$ or choose drive according to I_H . It is recommended to check the rating with your nearest distributor.

Drive overrating may also be necessary if the process requires high starting torque.

4.3 TECHNICAL DATA

*) NX_8 AC drives only available as Ch6x AFE/BCU/INU units. * **Note:** System software version

Table 13. Technical data

Mains connection	Input voltage U_{in}	NX_5: 400...500 VAC (-10%...+10%); 465...800 VDC (-0%...+0%) NX_6: 525...690 VAC (-10%...+10%); 640...1100 VDC (-0%...+0%) NX_8: 525...690 VAC (-10%...+10%); 640...1200 VDC (-0%...+0%)*)	
	Input frequency	45...66 Hz	
	Connection to mains	Once per minute or less	
	DC bank capacitance	Voltage class 500 V:	Ch3 (16-31A units): 410 μ F Ch3 (38-61A units): 600 μ F CH4: 2400 μ F CH5: 7200 μ F CH61: 10800 μ F CH62/CH72: 10800 μ F CH63: 21600 μ F CH64/CH74: 32400 μ F 2*CH64/2*CH74: 64800 μ F
	Voltage class 690 V:	CH61: 4800 μ F CH62/CH72: 4800 μ F CH63: 9600 μ F CH64/CH74: 14400 μ F 2*CH64/2*CH74: 28800 μ F	
Supply network	Networks	TN, TT, IT	
	Short circuit current	Maximum short circuit current has to be < 100 kA.	
Motor connection	Output voltage	0— U_{in}	
	Continuous output current	Rated current at nominal inflow cooling water temperature according to dimensioning charts.	
	Output frequency	0...320 Hz (standard); 7200 Hz (Special software)	
	Frequency resolution	Application dependent	
	Output filter	VACON® Liquid-Cooled NX_8 unit must be equipped with a du/dt- or sine-filter.	

Table 13. Technical data

Control characteristics	Control method	Frequency control U/f Open Loop Sensorless Vector Control Closed Loop Vector Control
	Switching frequency	NX_5: Up to and including NX_0061: 1...16 kHz; Factory default 10 kHz From NX_0072: 1...12 kHz; Factory default 3.6 kHz NX_6/ NX_8: 1...6 kHz; Factory default 1.5 kHz Derating required if higher switching frequency than the default is used! NOTE! DriveSynch paralleling concept: Recommended minimum switching frequency for open loop control 1.7 kHz and closed loop control 2.5 kHz. Maximum switching frequency 3.6 kHz. NOTE!
	<u>Frequency reference</u> Analogue input Panel reference	Resolution 0.1% (10-bit), accuracy ±1% Resolution 0.01 Hz
	Field weakening point	8...320 Hz
	Acceleration time	0.1...3000 sec
	Deceleration time	0.1...3000 sec
	Braking torque	DC brake: 30% * T _N (without brake option)

Table 13. Technical data

Ambient conditions	Ambient operating temperature	-10 °C (no frost)...+50 °C (at I _{th}) The VACON® NX Liquid-Cooled drives must be used in an heated indoor controlled environment.
	Installation temperature	0...+70 °C
	Storage temperature	-40 °C...+70 °C; No liquid in heatsink under 0 °C
	Relative humidity	5 to 96% RH, non-condensing, no dripping water
	Air quality: <ul style="list-style-type: none"> • chemical vapours • mechanical particles 	IEC 60721-3-3, unit in operation, class 3C2 IEC 60721-3-3, unit in operation, class 3S2 (no conductive dust allowed) No corrosive gases
	Altitude	NX_5: (380...500 V): max. 3000 m (in case network is not corner grounded) NX_6/NX_8: max. 2000 m. For further requirements, contact factory 100-% load capacity (no derating) up to 1,000 m; above 1,000 m derating of maximum ambient operating temperature by 0.5 °C per each 100 m is required.
	Vibration EN 50178/EN 60068-2-6	5...150 Hz Displacement amplitude 0.25 mm (peak) at 3...31 Hz Max. acceleration amplitude 1 G at 31...150 Hz
	Shock EN 50178, EN 60068-2-27	UPS Drop Test (for applicable UPS weights) Storage and shipping: max 15 G, 11 ms (in package)
	Enclosure class	IP00/Open Frame standard in entire kW/HP range
Pollution degree	PD2	
EMC	Immunity	Fulfils IEC/EN 61800-3 EMC immunity requirements
	Emissions	EMC level N for TN/TT networks EMC level T for IT networks
Safety		IEC/EN 61800-5-1 (2007), CE, UL, cUL, GOST R, (see unit nameplate for more detailed approvals) IEC 60664-1 and UL840 in overvoltage category III.
	Safe Torque Off (STO) board	The drive is equipped with VACON® OPTAF board for prevention of torque on motor shaft. Standards: prEN ISO 13849-1 (2004), EN ISO 13849-2 (2003), EN 60079-14 (1997), EN 954-1 (1996), cat. 3 (hardware disable); IEC 61508-3(2001), prEN 50495 (2006). See VACON® NX OPTAF STO Board User Manual for detailed information.

Table 13. Technical data

Control connections (apply to boards OPT-A1, OPT-A2 and OPT-A3)	Analogue input voltage	0...+10 V, $R_i = 200\text{ k}\Omega$, (-10 V...+10 V joystick control) Resolution 0.1%, accuracy $\pm 1\%$
	Analogue input current	0(4)...20 mA, $R_i = 250\text{ }\Omega$ differential
	Digital inputs (6)	Positive or negative logic; 18...24 VDC
	Auxiliary voltage	+24 V, $\pm 10\%$, max volt. ripple < 100 mVrms; max. 250 mA Dimensioning: max. 1000 mA/control box 1A external fuse required (no internal short-circuit protection on the control board)
	Output reference voltage	+10 V, +3%, max. load 10 mA
	Analogue output	0(4)...20 mA; R_L max. 500 Ω ; Resolution 10 bit; Accuracy $\pm 2\%$
	Digital outputs	Open collector output, 50 mA/48 V
	Relay outputs	2 programmable change-over relay outputs Switching capacity: 24 VDC/8 A, 250 VAC/8 A, 125 VDC/0.4 A Min. switching load: 5 V/10 mA
Protections	Overvoltage trip limit	NX_5: 911 VDC NX_6: (CH61, CH62, CH63 & CH64): 1258 VDC NX_6: (CH72 & CH74): 1200 VDC NX_8: (CH61, CH62, CH63 & CH64): 1300 VDC
	Undervoltage trip limit	NX_5: 333 VDC; NX_6: 461 VDC; NX_8: 461 VDC
	Earth fault protection	In case of earth fault in motor or motor cable, only the AC drive is protected.
	Mains supervision	Trips if any of the input phases is missing (AC drives only).
	Motor phase supervision	Trips if any of the output phases is missing.
	Unit overtemperature protection	Alarm limit: 65 °C (heatsink); 75 °C (circuit boards). Trip limit: 70 °C (heatsink); 85 °C (circuit boards).
	Overcurrent protection	Yes
	Motor overload protection	Yes * Motor overload protection provided at 110% of full motor load current.
	Motor stall protection	Yes
	Motor underload protection	Yes
Short-circuit protection of +24 V and +10 V reference voltages	Yes	

*) NXP00002V186 (or newer) must be used for the motor thermal memory and memory retention functionality to conform to UL 508C requirements. If an older system software version is used, motor overtemperature protection is required at installation to comply with UL requirements.

Table 13. Technical data

Liquid cooling	Allowed cooling agents	Drinking water (see specification on page 49). Water-glycol mixture. See derating specifications, Chapter 5.3.
	Volume	See page 51.
	Temperature of cooling agent	0...35 °C input (I_{th}); 35...55 °C: derating required, see Chapter 5.3. Max. temperature rise during circulation max. 5 °C No condensation allowed. See Chapter 5.2.1.
	Cooling agent flow rates	See Table 15.
	System max. working pressure	6 bar
	System max. peak pressure	30 bar
	Pressure loss (at nom. flow)	Varies according to size. See Table 17.

5. INSTALLATION

5.1 MOUNTING

VACON® NX Liquid-Cooled Drive modules must be installed into an enclosure. The drives consisting of one module will be mounted on the mounting plate. The drives that include two or three modules are mounted inside a mounting bracket (see table below) which will then be installed in the enclosure.

NOTE! If any other than vertical installation position is required, contact your distributor!

NOTE! The allowed installation temperature is 0...+70 °C.

In Chapter 5.1.2 you will find the dimensions of VACON® NX Liquid-Cooled drives installed on mounting bases (plates and brackets).

5.1.1 LIFTING THE DRIVE

We recommend you to always use a jib crane or similar elevating device to lift the AC drive/ inverter unit. See figures below for correct lifting points.

For units with no mounting bracket (see Chapter 5.1.2.1), the best place for hoisting is the hole(s) in the middle of the mounting plate (Lifting point 1). VACON® NX Liquid-Cooled drives consisting of several modules can the most safely and easily be lifted by the holes in the mounting bracket (Lifting point 2) using a screw pin shackle. Pay also attention to the recommended dimensions of the hoisting belt and the beam. See Figure 3.

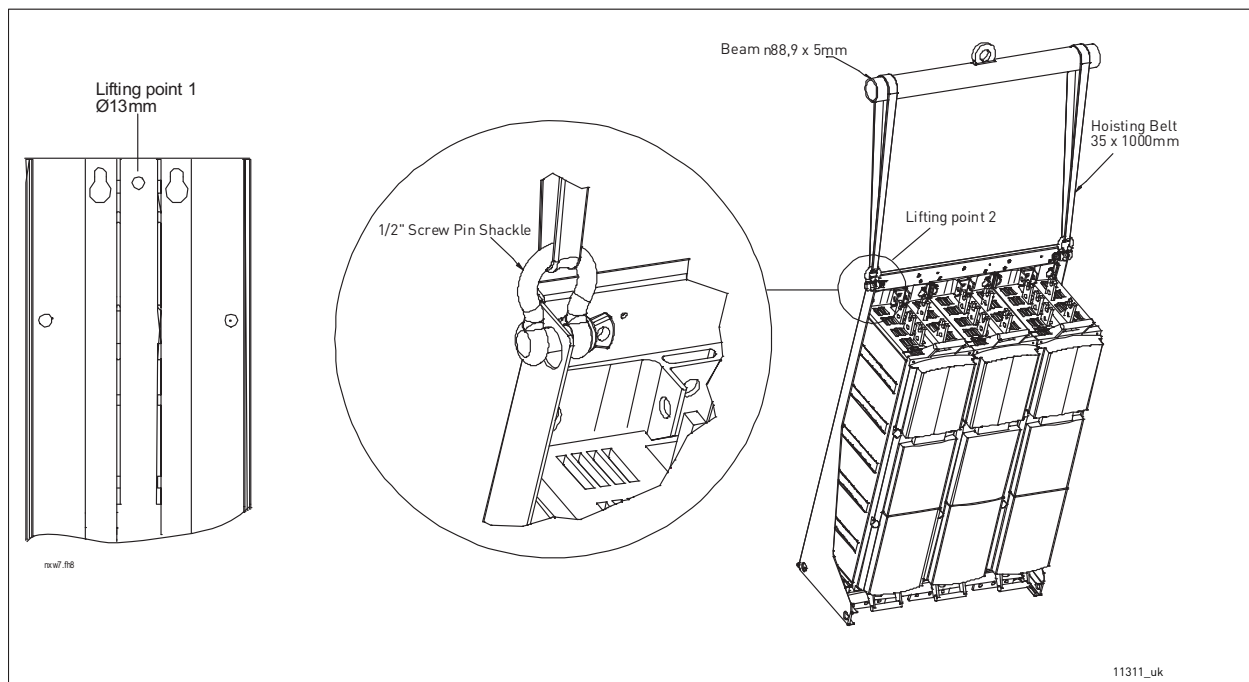

Figure 3. Lifting points for drives consisting of one module (left) and several modules

In cabinet installation, the hoisting procedure described above right may, however, become difficult or even impossible if the cabinet width does not allow the use of the screw pin shackle in Lifting point 2 (see above).

In such case, follow the lifting procedure described in Figure 4. The mounting becomes easier and safer if the drive can be laid on a supporting girder fixed on the cabinet frame. We also recommend to use an aligning stud to guarantee an easy and safe mounting.

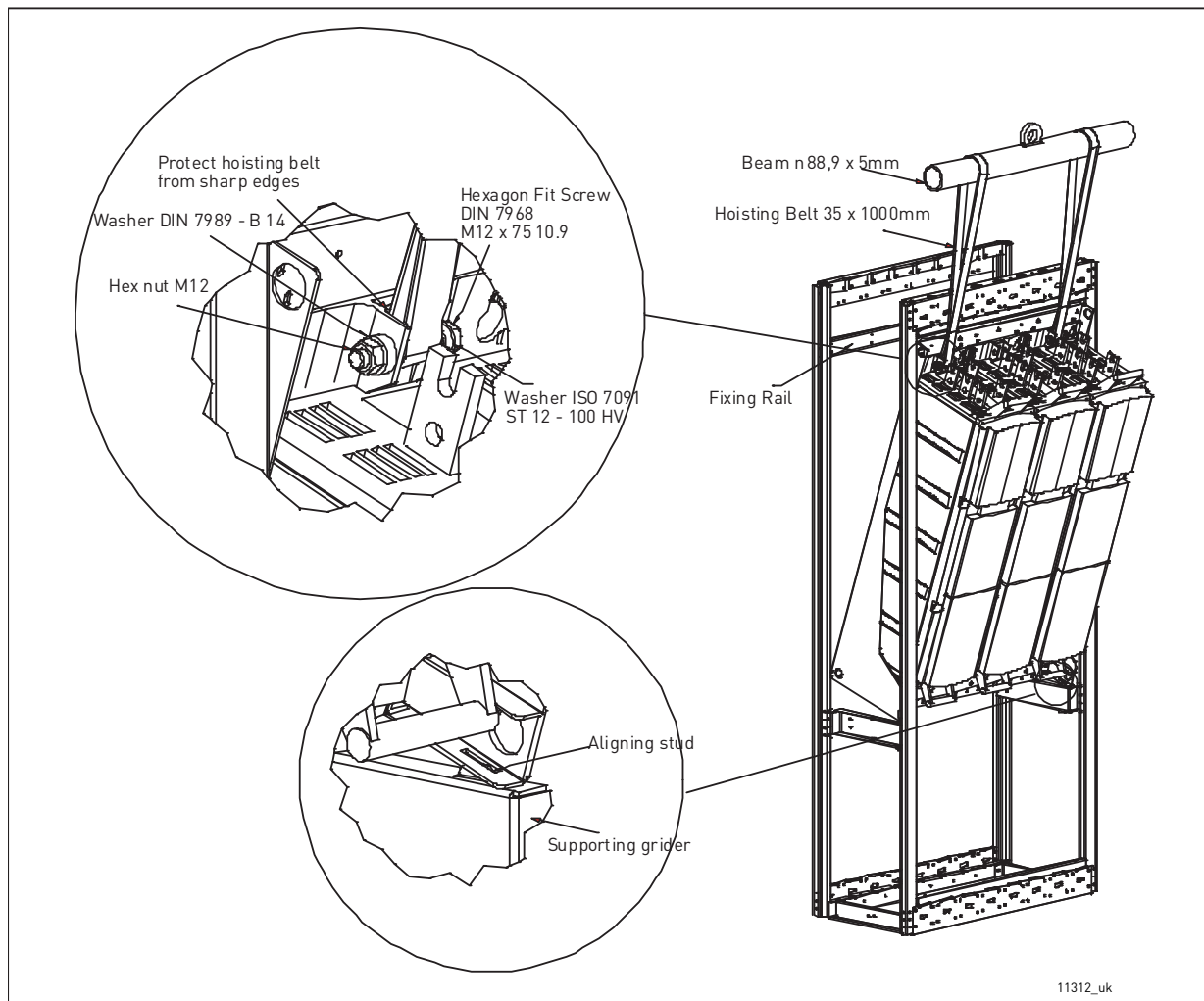

Figure 4. Lifting of drive into a narrow mounting space

To additionally stabilize the cabinet with the drive, we recommend to mount a fixing rail on the back of the cabinet, to which the top of the drive can be fastened with 5 or 6 M5 screws. The cut-out is compatible with Rittal or Veda cabinets. Also secure the drive with M8 nuts and studs to the supporting girder. See Figure 4 and Figure 5.

The VACON® NX Liquid-Cooled drives are equipped with plastic handles and these handles can be used to move and lift drives consisting of one power module (CH61, CH62, & CH72) by hand.

NOTE! Never lift a drive from the plastic handle or handles with an elevating device, such as jib crane or hoist. Recommended lifting procedure for these units are as described in Figure 3 and Figure 4.

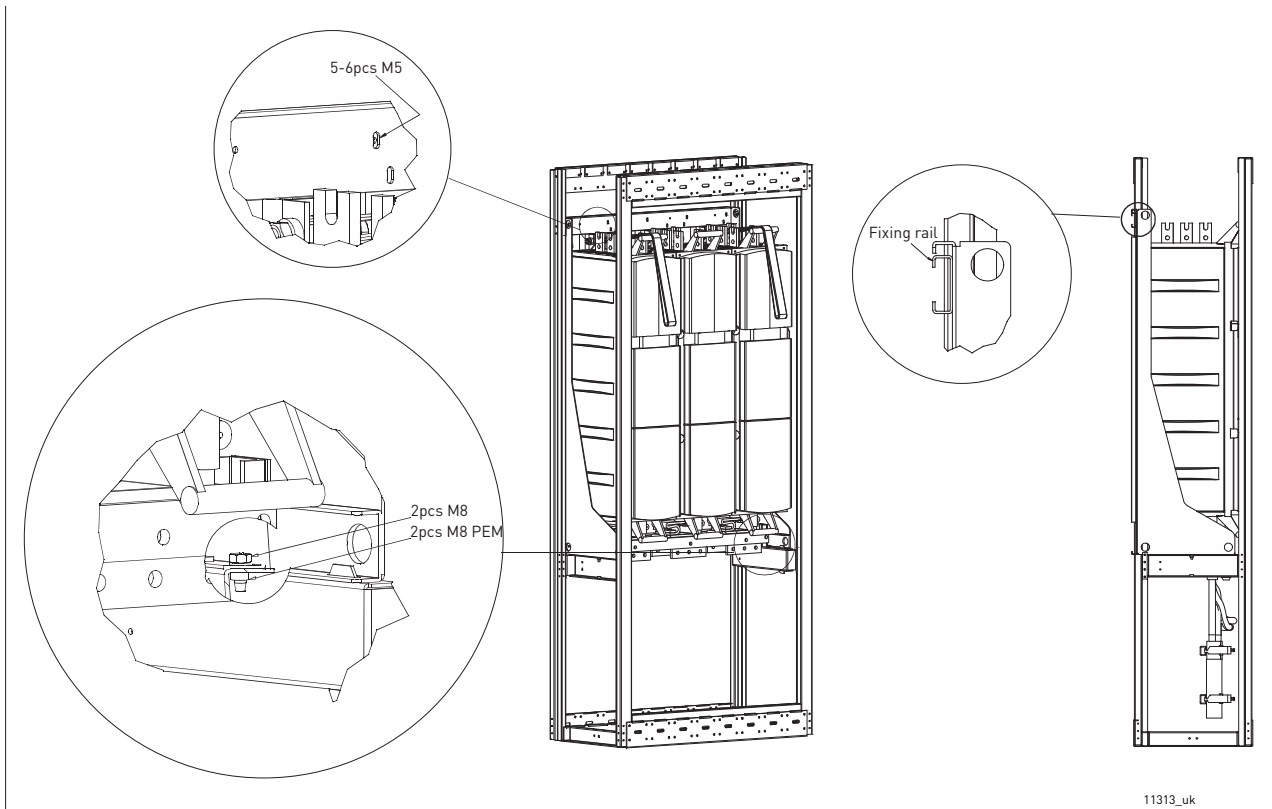

Figure 5. Securing the drive to the cabinet frame

5.1.2 VACON® NX LIQUID-COOLED DIMENSIONS

5.1.2.1 Drives consisting of one module

Table 14. One-module drive dimensions (mounting base included)

Chassis	Width	Height	Depth	Weight*
CH3	160	431	246	15
CH4	193	493	257	22
CH5	246	553	264	40
CH61/62	246	658	372	55
CH72	246	1076	372	90

*. AC choke excluded.

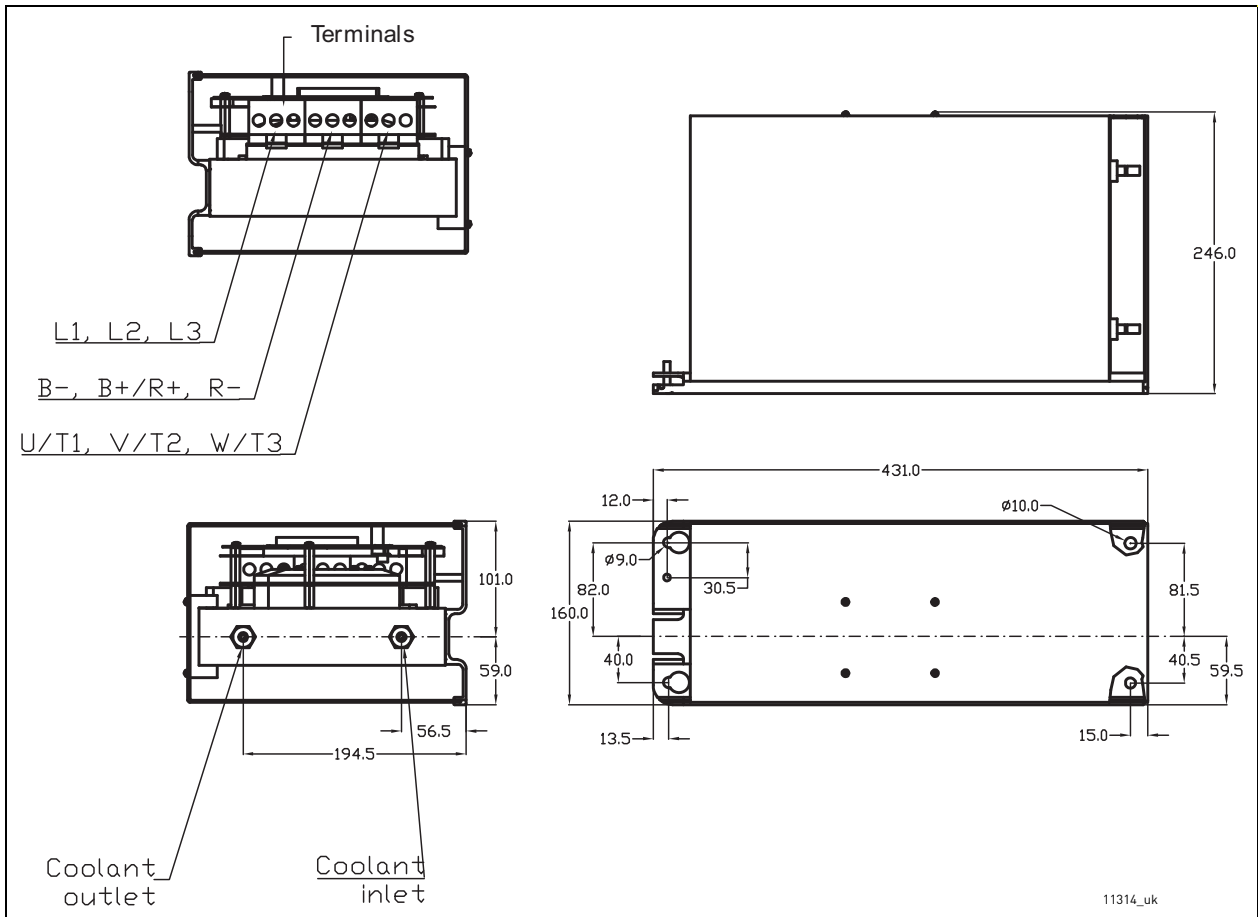

Figure 6. VACON® NX Liquid-Cooled drive dimensions, CH3

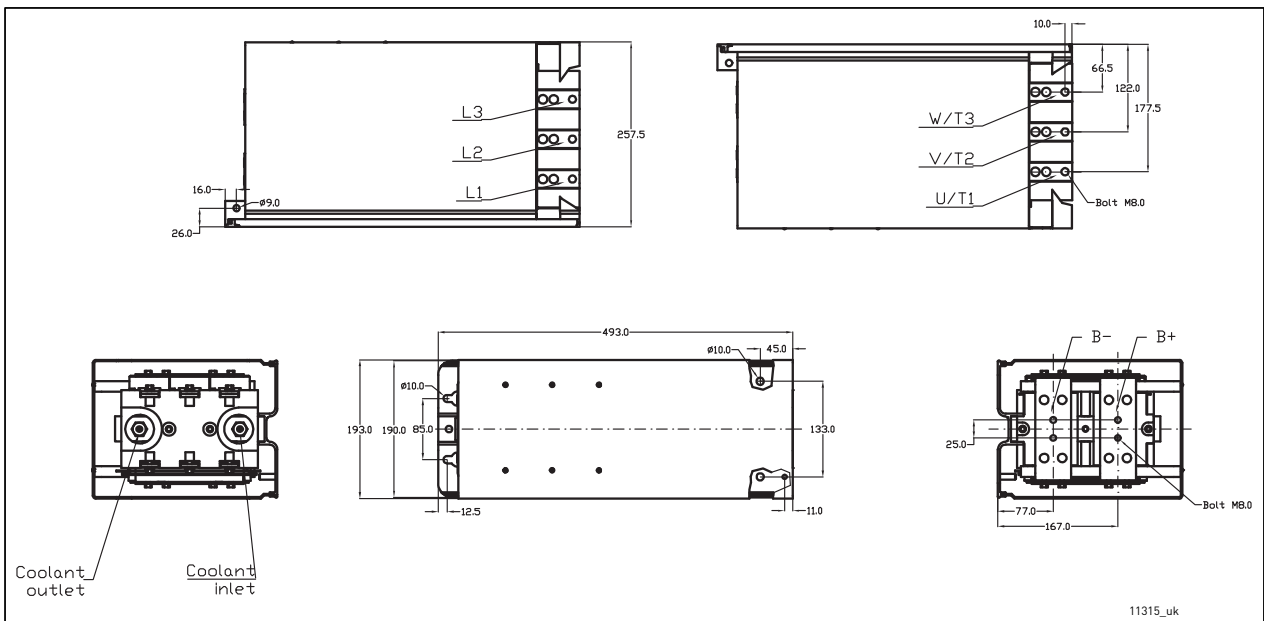

Figure 7. VACON® NX Liquid-Cooled drive dimensions (AC drive), CH4

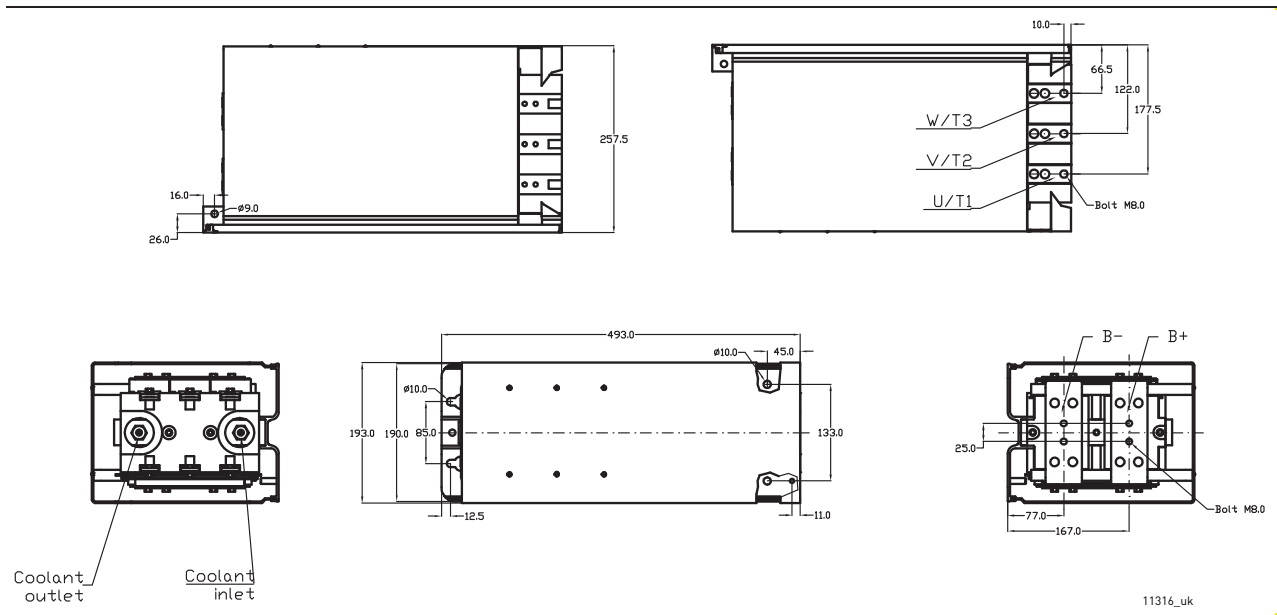

Figure 8. VACON® NX Liquid-Cooled drive dimensions (inverter), CH4

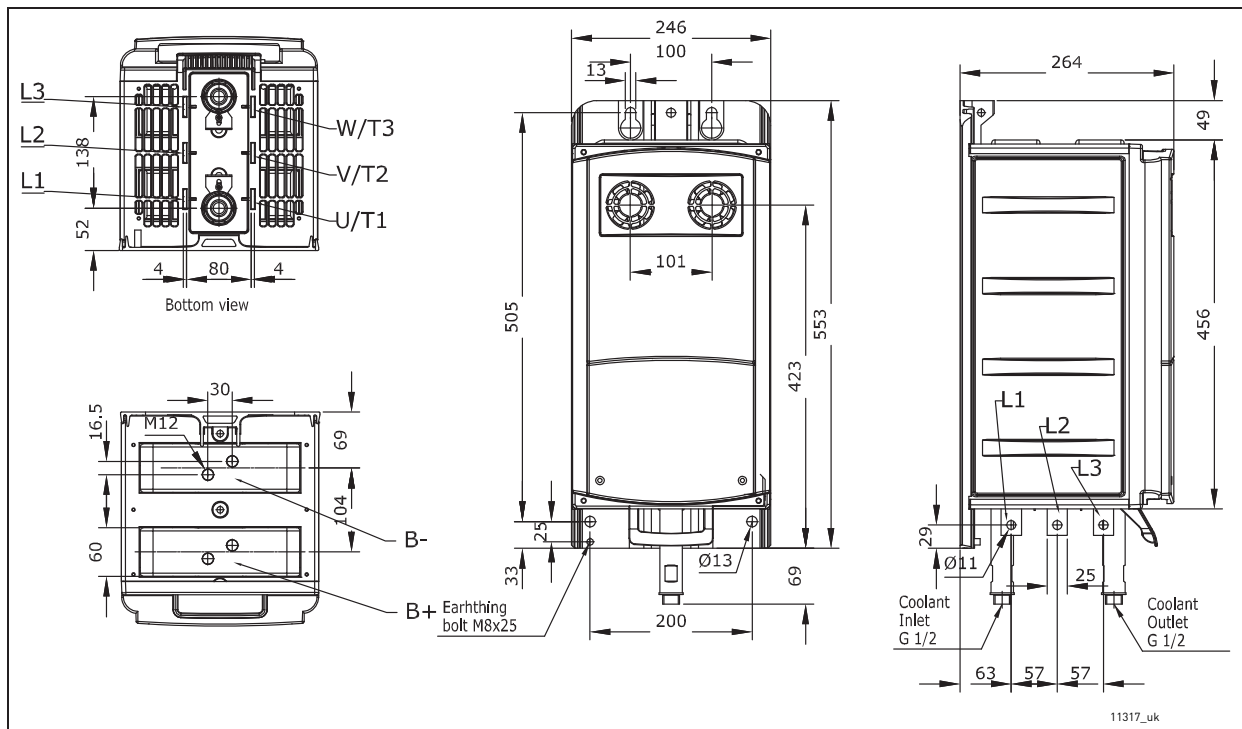

Figure 9. VACON® NX Liquid-Cooled dimensions, CH5 AC drive

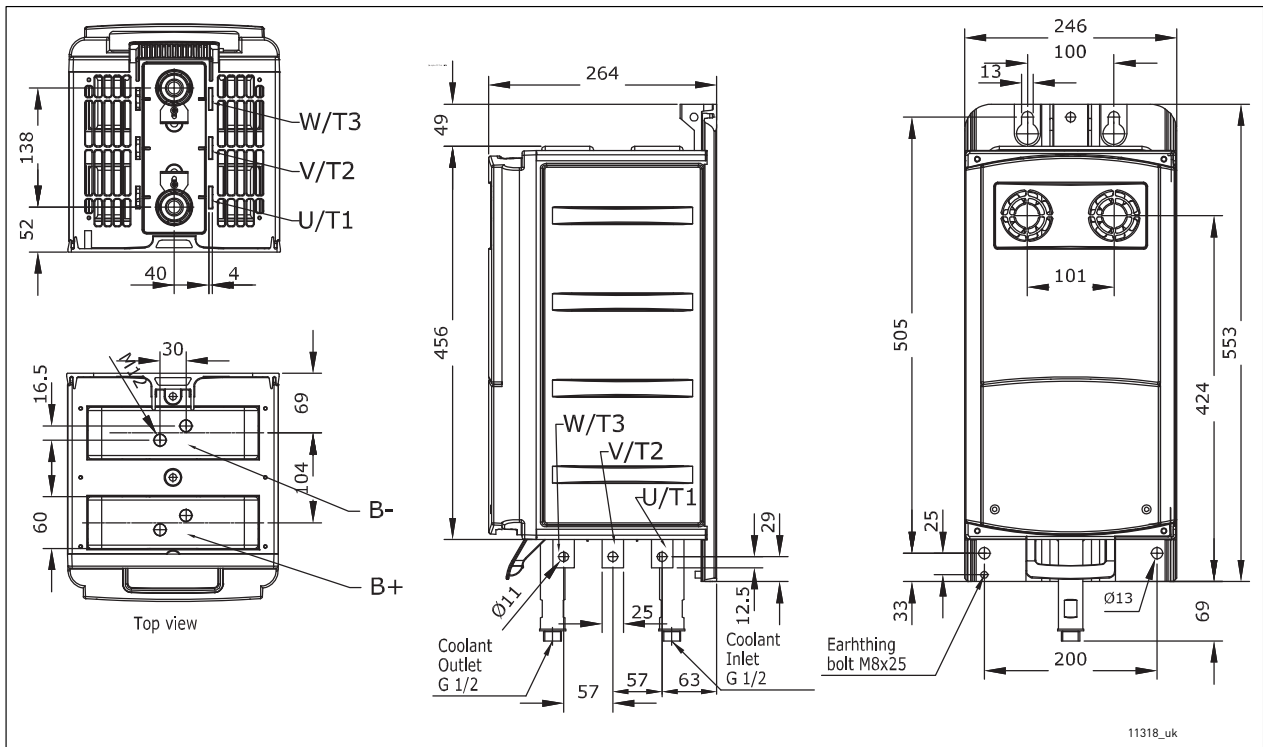

Figure 10. VACON® NX Liquid-Cooled dimensions, CH5 inverter

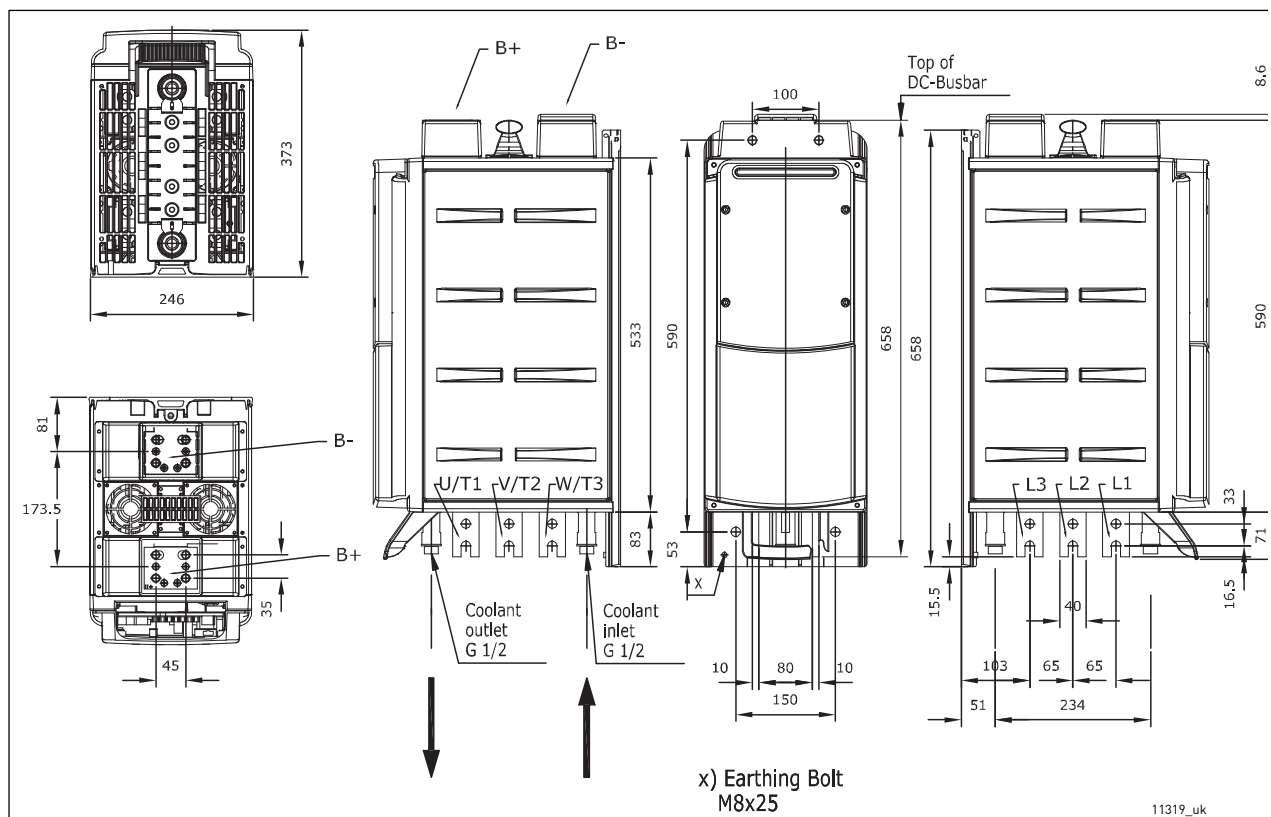
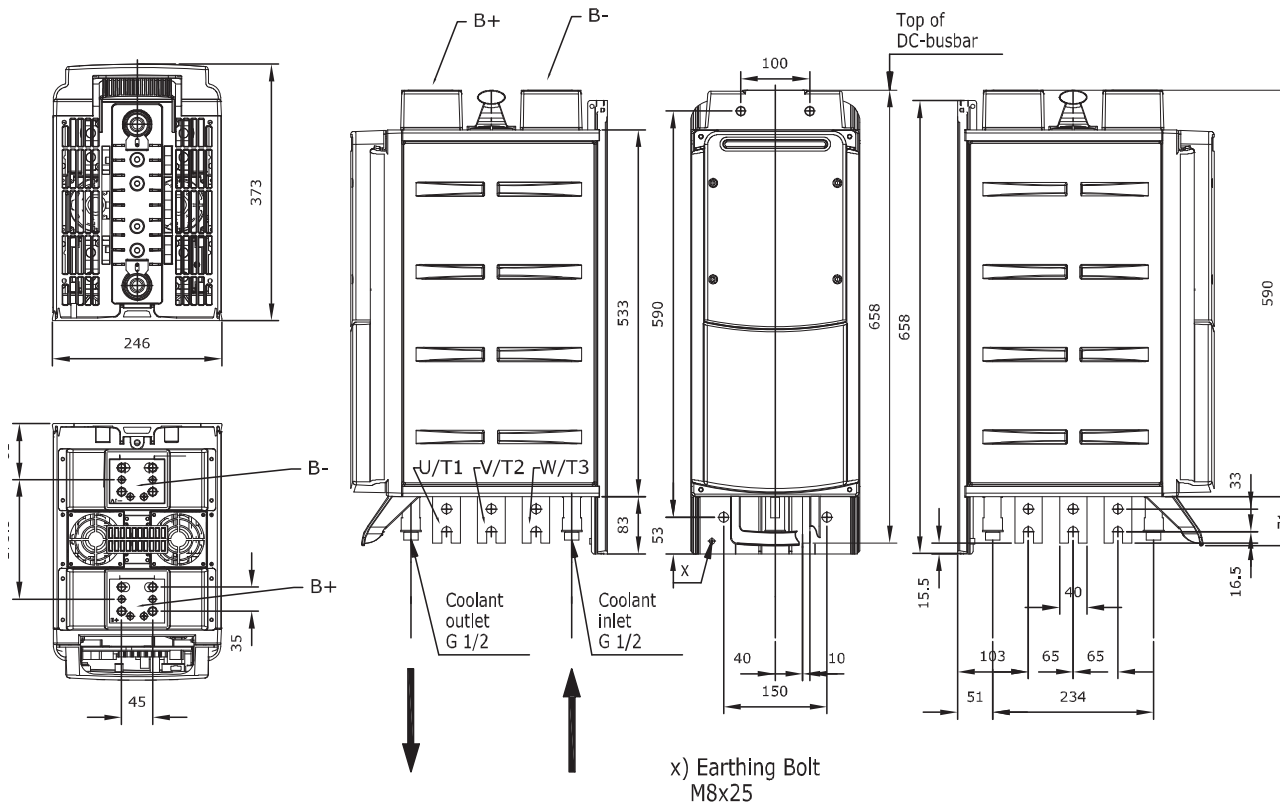

Figure 11. VACON® Liquid-Cooled AC drive, CH61



11320_uk

Figure 12. VACON® Liquid-Cooled inverter, CH61

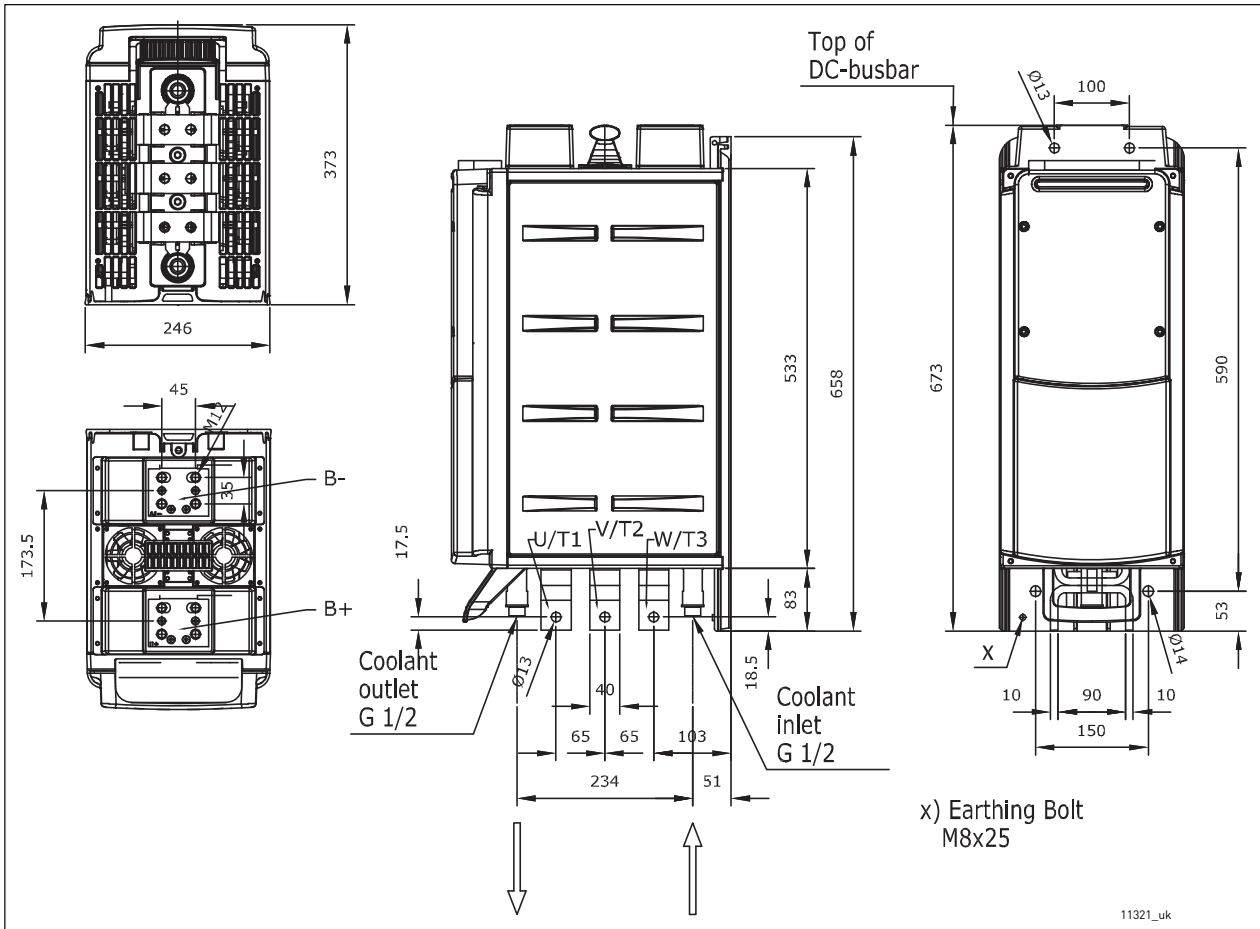

Figure 13. VACON® Liquid-Cooled inverter, CH62

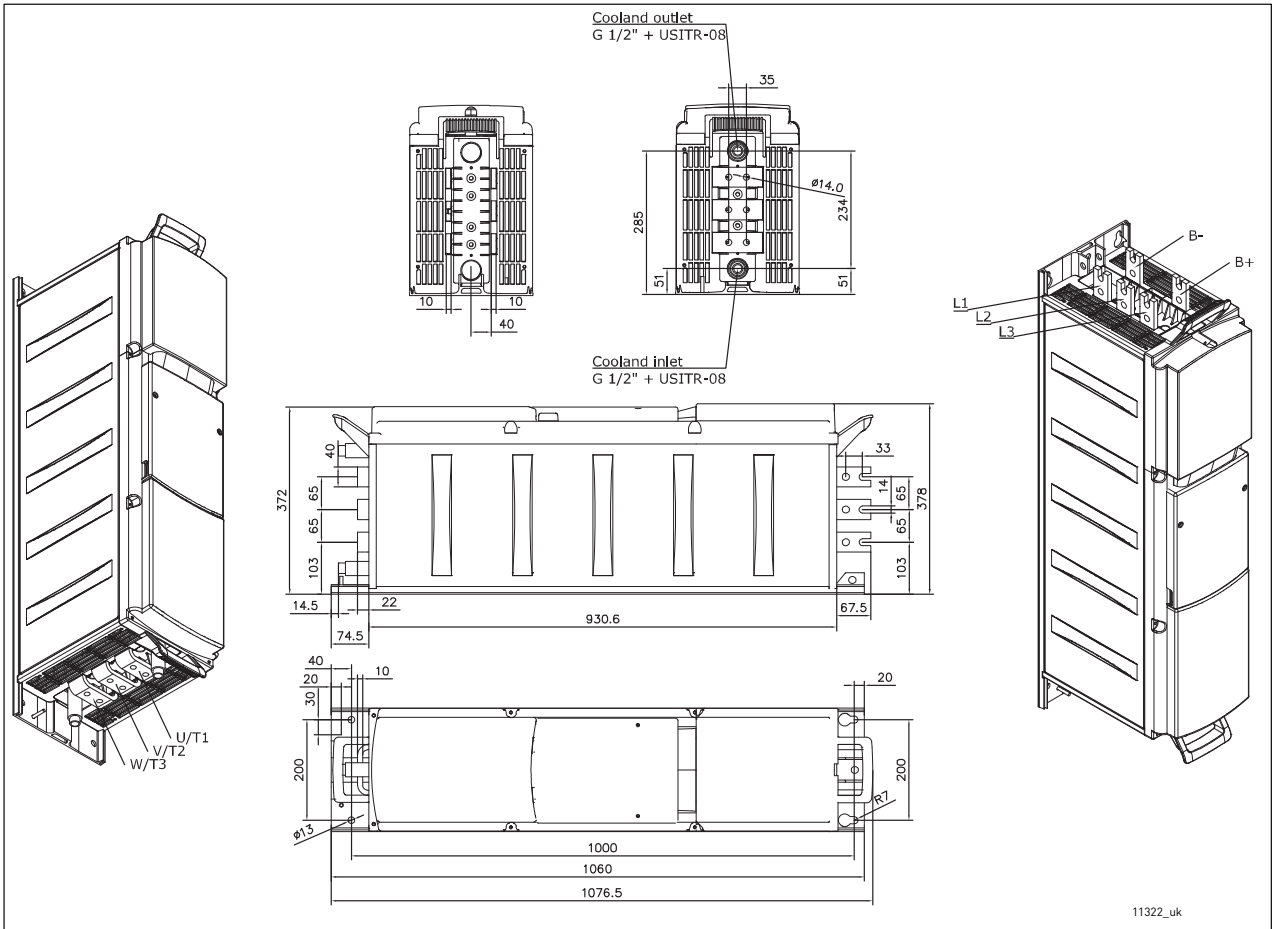

Figure 14. VACON® Liquid-Cooled AC drive (6-pulse), CH72

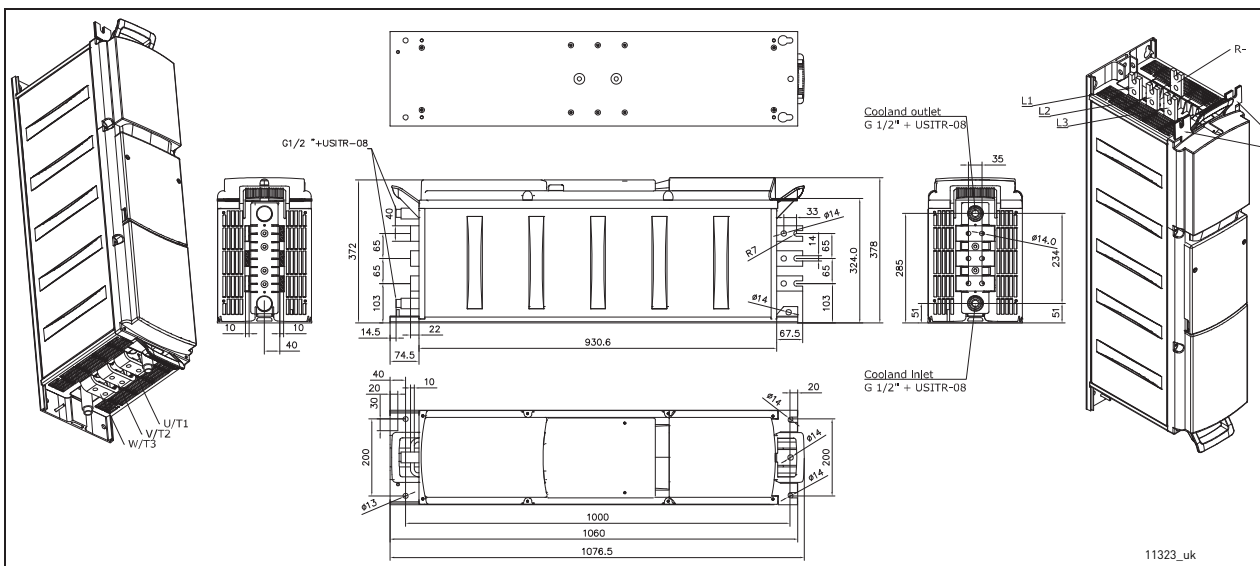

Figure 15. VACON® Liquid-Cooled AC drive (6-pulse) with internal brake chopper

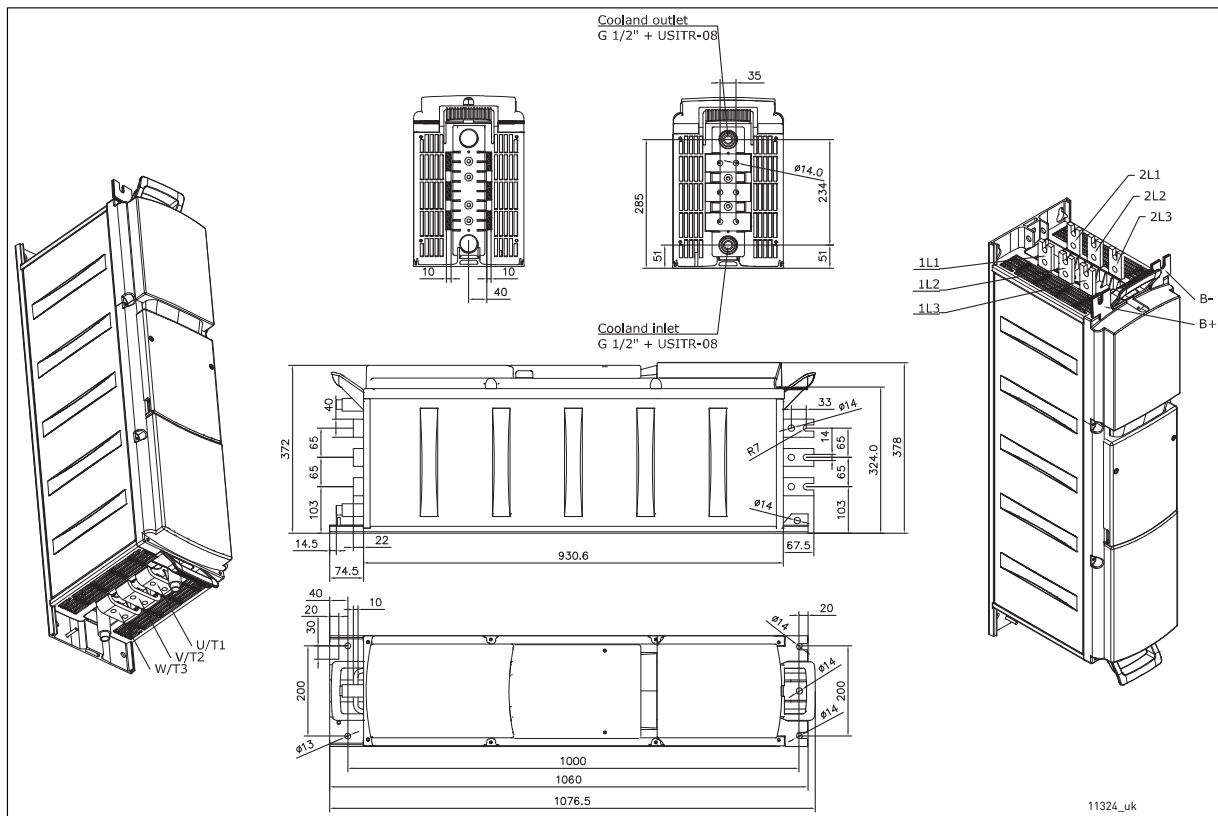

Figure 16. VACON[®] Liquid-Cooled AC drive (12-pulse), CH72

5.1.2.2 Drives consisting of several modules

VACON[®] NX Liquid-Cooled drives consisting of several modules are mounted in a mounting bracket as presented in Figure 17.

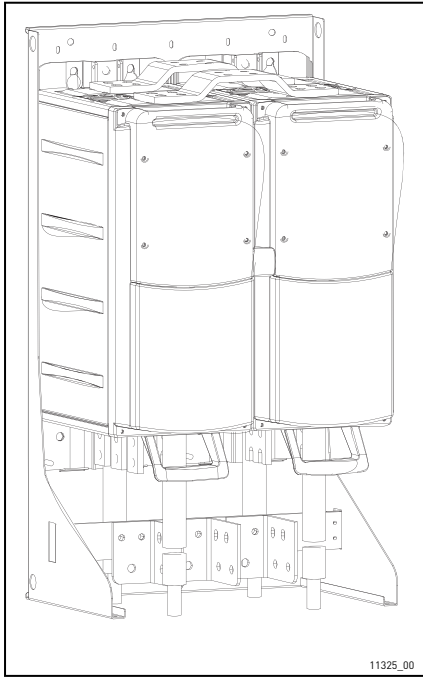
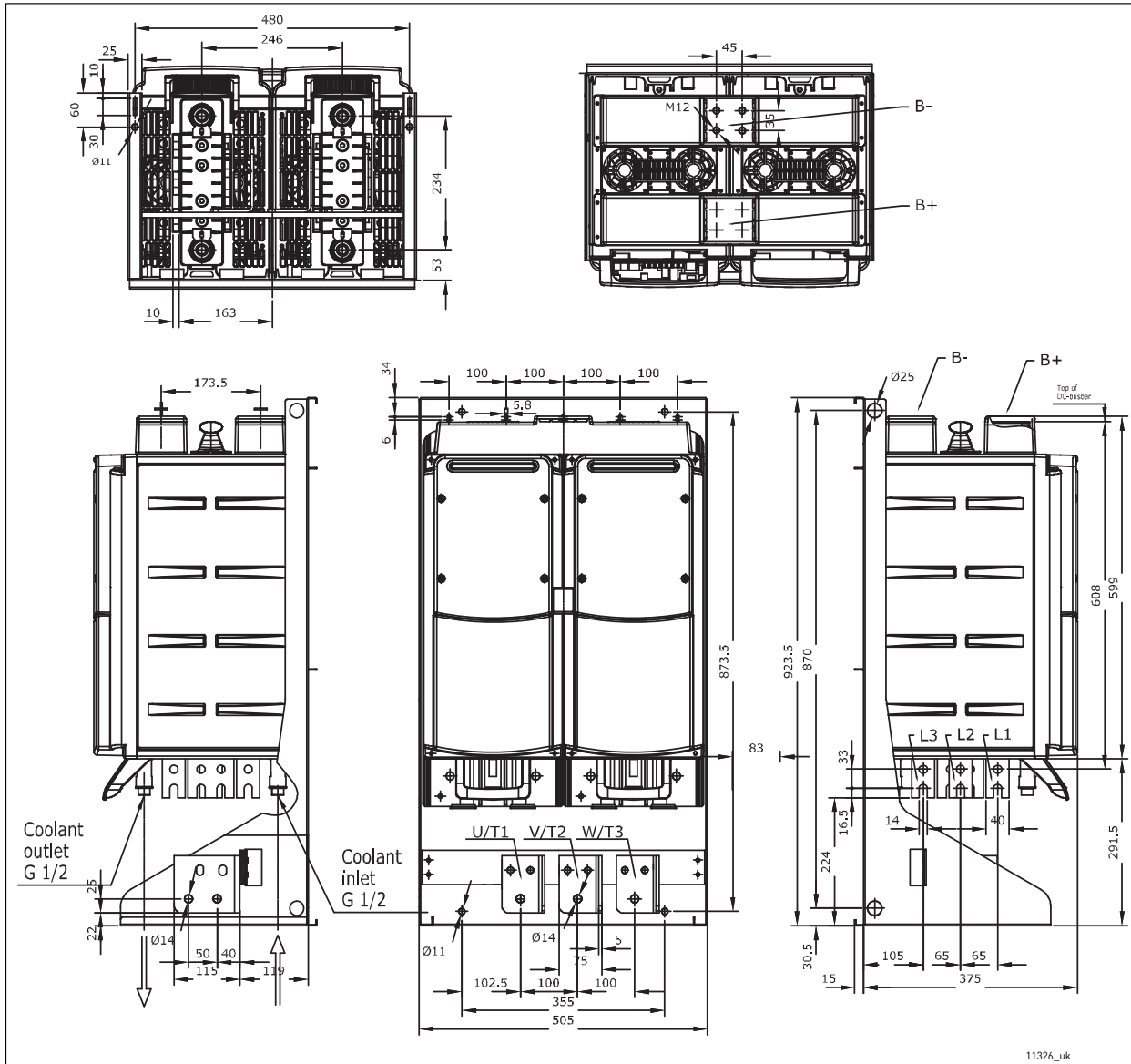

Table 15. Several-module drive dimensions (mounting bracket incl.)

Chassis	Width	Height	Depth	Weight
CH63	505	924	375	120
CH64	746	924	375	180
CH74	746	1175	385	280

Figure 17. Drive mounted inside mounting bracket



11326_uk

Figure 18. VACON® Liquid-Cooled AC drive with mounting bracket, CH63

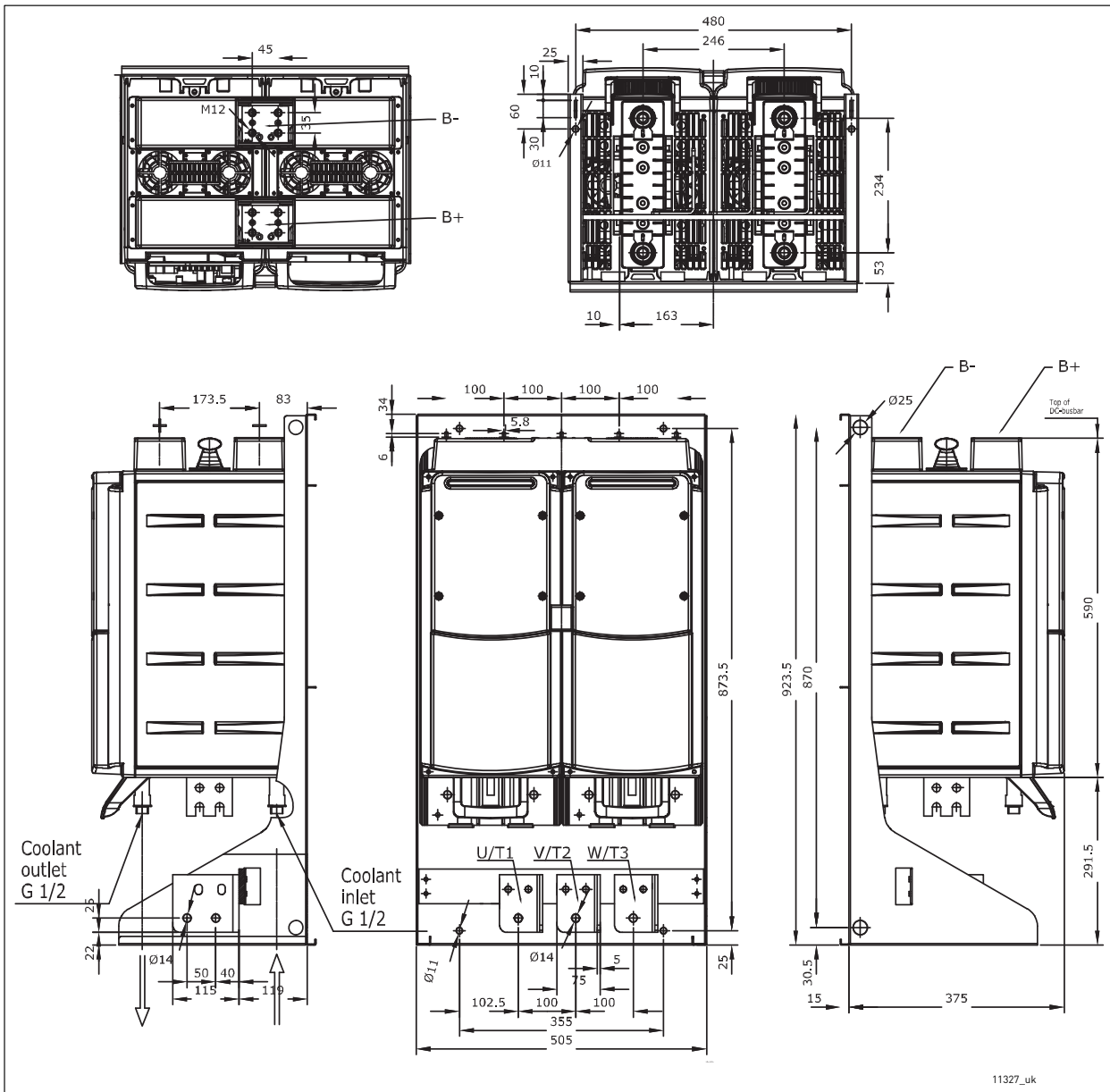

Figure 19. VACON[®] Liquid-Cooled inverter with mounting bracket, CH63

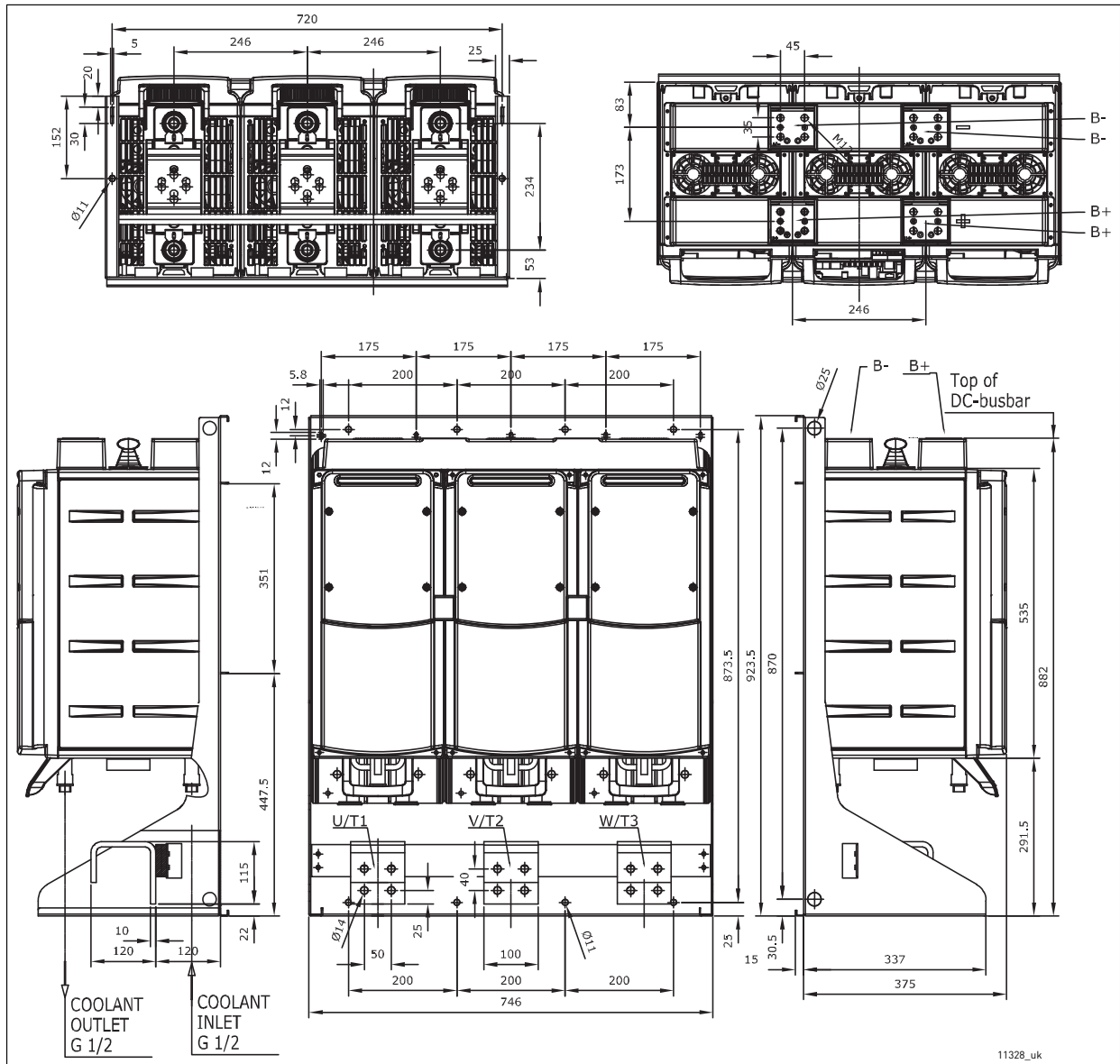

Figure 20. VACON[®] NX Liquid-Cooled inverter dimensions, CH64, IP00

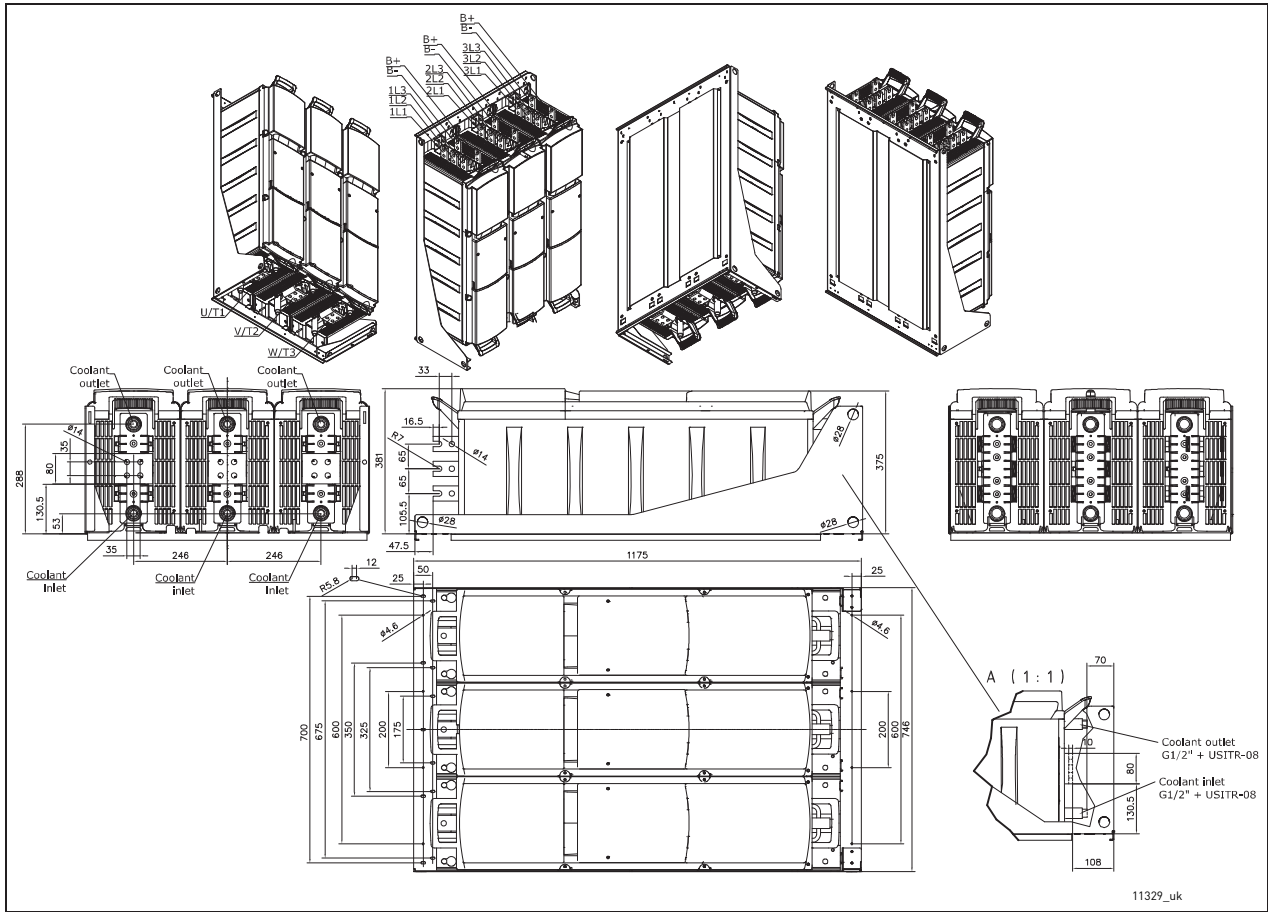

Figure 21. VACON® NX Liquid-Cooled AC drive (6-pulse) dimensions, CH74, IP00

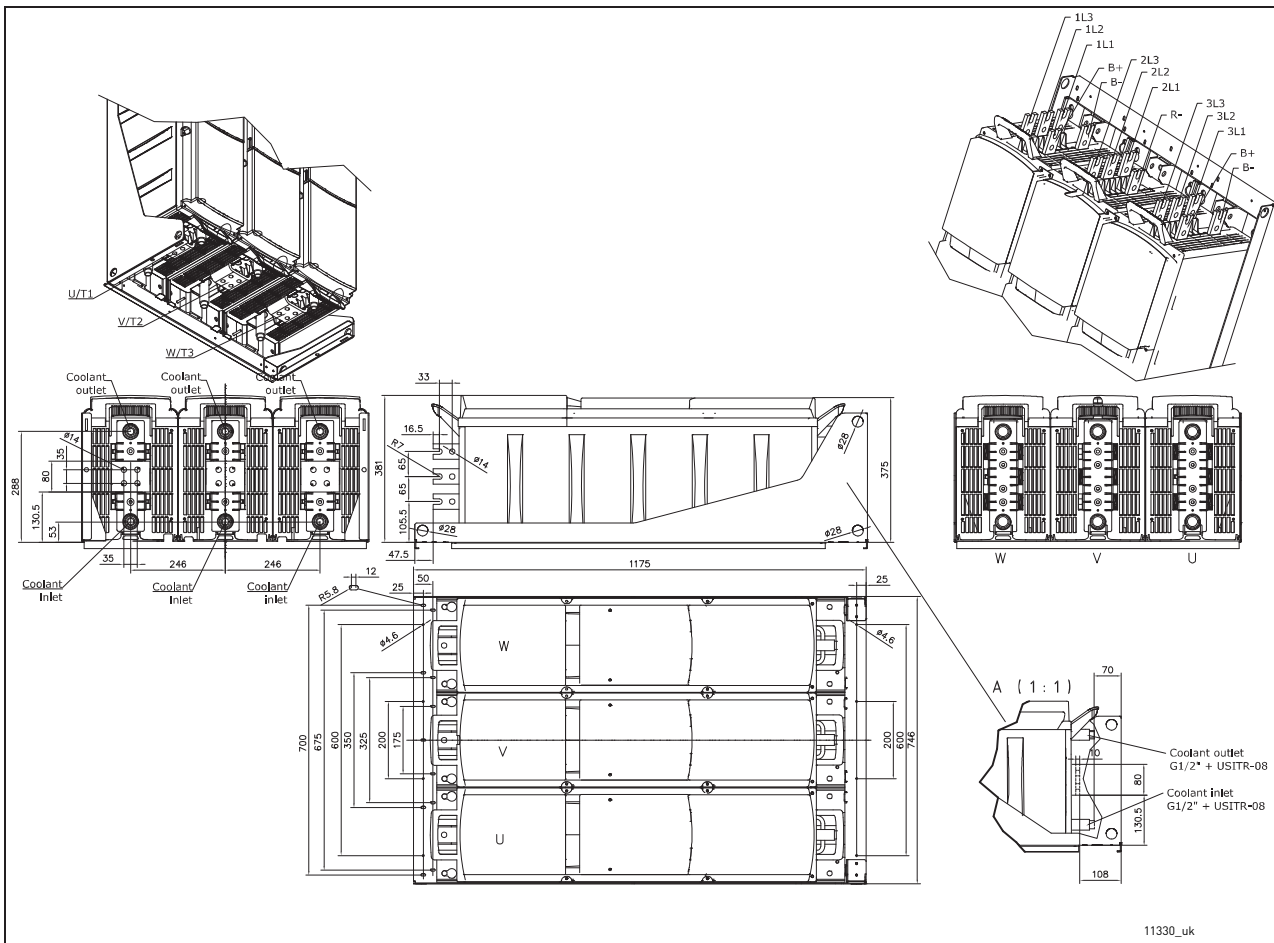
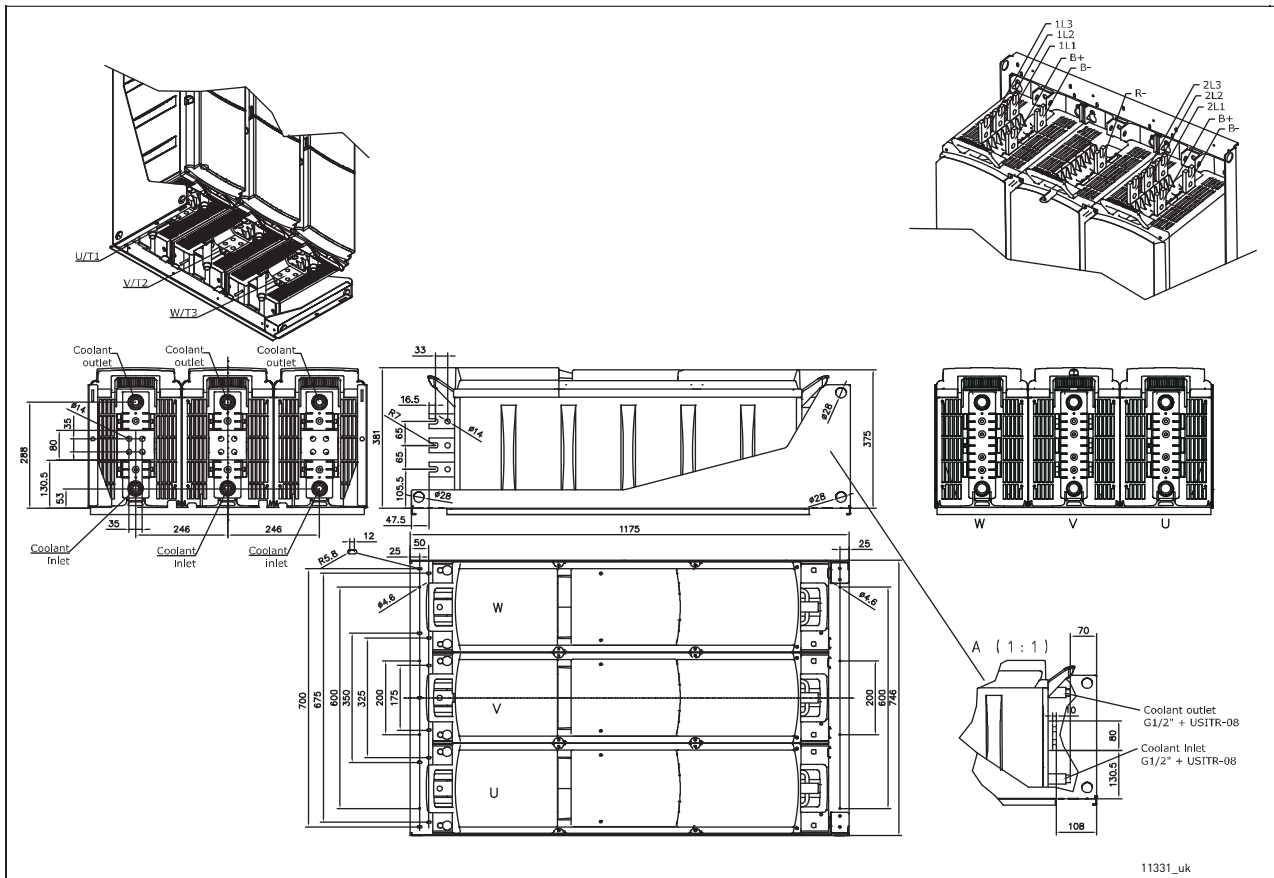

Figure 22. VACON[®] NX Liquid-Cooled AC drive (6-pulse) with internal brake chopper dimensions, CH74, IP00



11331_uk

Figure 23. VACON[®] NX Liquid-Cooled AC drive (12-pulse) with internal brake chopper dimensions, CH74, IP00

5.2 COOLING

Instead of using air for cooling, VACON® NX Liquid-Cooled drives are cooled with liquid. The liquid circulation of the drive is usually connected to a heat-exchanger (liquid-liquid/liquid-air) which cools down the liquid circulating in the cooling elements of the drive. Because the cooling elements are made of aluminium, the cooling agents allowed to be used are drinking water, demineralized water or a mixture of water and glycol.

There are two types of circulation system: open systems and closed systems.

An open system has no pressure, and allows free contact with air.

In a closed system, the piping is completely air-tight and there is pressure inside the pipes. The pipes must be made of metal, or specific plastic or rubber that includes an oxygen barrier. Preventing of oxygen diffusion in the coolant diminishes the risk of electrochemical corrosion of the metal parts, and generation of rust deposits. Always use a closed system with VACON® NX Liquid-Cooled drives.

In case there is no other option than using an open system, you must take several precautions.

1. Use glycol and inhibitor in the coolant.
2. Examine the water quality regularly, and add inhibitor accordingly.
3. Yearly check that the properties of the cooling liquid are in accordance with the specification in this manual.

In a closed circulation system, the following figures are recommended reference values. To avoid electrochemical corrosion, it is necessary to add an inhibitor (e.g. Cortec VpCl-649) in the cooling agent.

Add inhibitor to the cooling agent every 2 years and change the cooling agent every 6 years.

The addition of each 0.05% of VpCl-649 into the cooling agent increases the electrical conductivity with 75-100 µS. The maximum value depends on the added dosage rate.

The heat-exchanger delivered by VACON® (HX) consists of stainless steel materials. The good corrosion performance of stainless steel in district water systems is utilized and no disadvantage of divergent metal filler is included. Nevertheless, some precautions must be taken to reduce the corrosion risk on the stainless steel in high chloride waters, see Table 18. We recommend to use a VACON® HX heat exchanger whenever possible.

NOTE! If no heat-exchanger is used, actions must be taken to avoid electrochemical corrosion. Specifically no brass or copper elements may be used in the liquid circulation of the drive.

Copper and brass may be used in the liquid circulation in case the liquid-cooled drive is equipped with a nickel coated aluminum heatsink.

Specification: Drinking water

The attached table gives the chemical requirements for drinking water provided for by the Finnish Ministry of Social Affairs and Health. These values are indicative.

Table 16. Drinking water chemical specification

Quality	Unit	Value
Acrylamide	µg/l	0.10
Antimony	µg/l	5.0
Arsenic	µg/l	10
Benzene	µg/l	1.0

Table 16. Drinking water chemical specification

Quality	Unit	Value
Benzopyrene	µg/l	0.010
Boron	mg/l	1.0
Bromate	µg/l	10
Cadmium	µg/l	5.0
Chromium	µg/l	50
Copper	mg/l	2.0
Cyanides	µg/l	50
1,2-Dichloroethane	µg/l	3.0
Epichlorohydrin	µg/l	0.10
Fluoride	mg/l	1.5
Lead	µg/l	10
Mercury	µg/l	1.0
Nickel	µg/l	20
Nitrate (NO ₃ ⁻)	mg/l	50
Nitrate-Nitrogen (NO ₃ -N)	mg/l	11.0
Nitrite (NO ₂ ⁻)	mg/l	0.5
Nitrite-Nitrogen (NO ₂ -N)	mg/l	0.15
Bactericides	µg/l	0.10
Bactericides, total	µg/l	0.50
Polynuclear aromatic hydrocarbons	µg/l	0.10
Selenium	µg/l	10
Tetrachloroethylene and trichloroethylene tot.	µg/l	10
Trihalomethanes tot.	µg/l	100
Vinyl chloride	µg/l	0.50
Chlorophenols total	µg/l	10

Table 17. Drinking water quality recommendations

Quality	Unit	Max. value
Aluminium	µg/l	200
Ammonium (NH ₄ ⁺)	mg/l	0.50
Ammonium (NH ₄ -N)	mg/l	0.40
Chloride ¹⁾	mg/l	<100
Manganese	µg/l	50
Iron	µg/l	<0.5
Sulphate ^{1) 2)}	mg/l	250
Sodium	mg/l	200
Oxidizability (COD _{Mn} -O ₂)	mg/l	5.0
Quality	Unit	Desired value
Clostridium perfringens (including spores)	pmy/100 ml	0
Coliform bacteria	pmy/100 ml	0
Bacterial count (22 °C)		No unusual changes
pH ¹⁾	pH	6...8
Electrical conductivity ¹⁾	µS/cm	<100
Turbidity		To be approved by user and no unusual changes
Colour		No unusual changes
Smell and taste		No unusual changes
Total organic carbon (TOC)		No unusual changes
Tritium	beq/l	100
Indicative total dose	mSv/year	0.10
Water hardness	°dH	3...10
Max. particle size in coolant	µm	300

Notes:

1) No aggressive water allowed.

2) To avoid corrosion of piping, the sulphate content must not exceed 150 mg/l.

The cleanness of the heat exchanger, and therefore the heat exchanging capacity, depend on the purity of the process water. The more impure the water, the more frequently the heat exchanger needs cleaning. The following figures are reference values required of cooling circuit process water:

Specification: Process water*Table 18. Process water specification*

Quality	Unit	Value
pH		6...9
Water hardness	°dH	<20
Electrical conductivity	µS/cm	<100
Chlorides (Cl) *	mg/l	<100
Iron (Fe)	mg/l	<0.5

*. The allowed concentration of chloride ions (Cl⁻): <1000 ppm at 20 °C, < 300 ppm at 50 °C and < 100 ppm at 80 °C; the values are given as guidance to reduce the corrosion risk on stainless steel. The values are valid for pH=7. Lower pH value increases the risk.

The design temperature of the cooling agent entering the drive module(s) is 35 °C. While circulating inside the cooling element, the liquid transfers the heat produced by the power semiconductors (and the capacitors). The design temperature rise of the cooling agent during the circulation is less than 5 °C. Typically, 95% of the power losses is dissipated in the liquid. We advise you to equip the cooling agent circulation with temperature supervision.

The heat exchanging equipment can be located outside the electrical room in which the AC drives are. The connections between these two are made on site. In order to minimize the pressure drops, the pipings must be made as straight as possible. We further recommend that a regulating valve equipped with a measurement point is mounted. This makes the measurement and regulation of liquid circulation possible in the commissioning phase.

In order to prevent dirt particles from accumulating in the connections and thus gradually weakening the cooling effect, installation of filters is also recommended.

The highest point of the piping must be equipped with either an automatic or a manual venting device. The material of the piping must comply with at least AISI 304 (AISI 316 is recommended).

Prior to the actual connection of the pipes, the bores must be cleaned thoroughly. If cleaning with water is not possible, although recommended, pressured air must be used to remove all loose particles and dust.

To facilitate the cleaning and venting of the coolant circulation, we recommend you to install a bypass valve in the main line and valves at each AC drive inlet. Open the bypass valve and shut the valves to the AC drive when cleaning and airing the system. On commissioning the system, the bypass valve must be closed and the valves to the AC drives opened.

Below you will find a simplified example of the cooling system as well as an example of the connections between the AC drives and the cooling system.

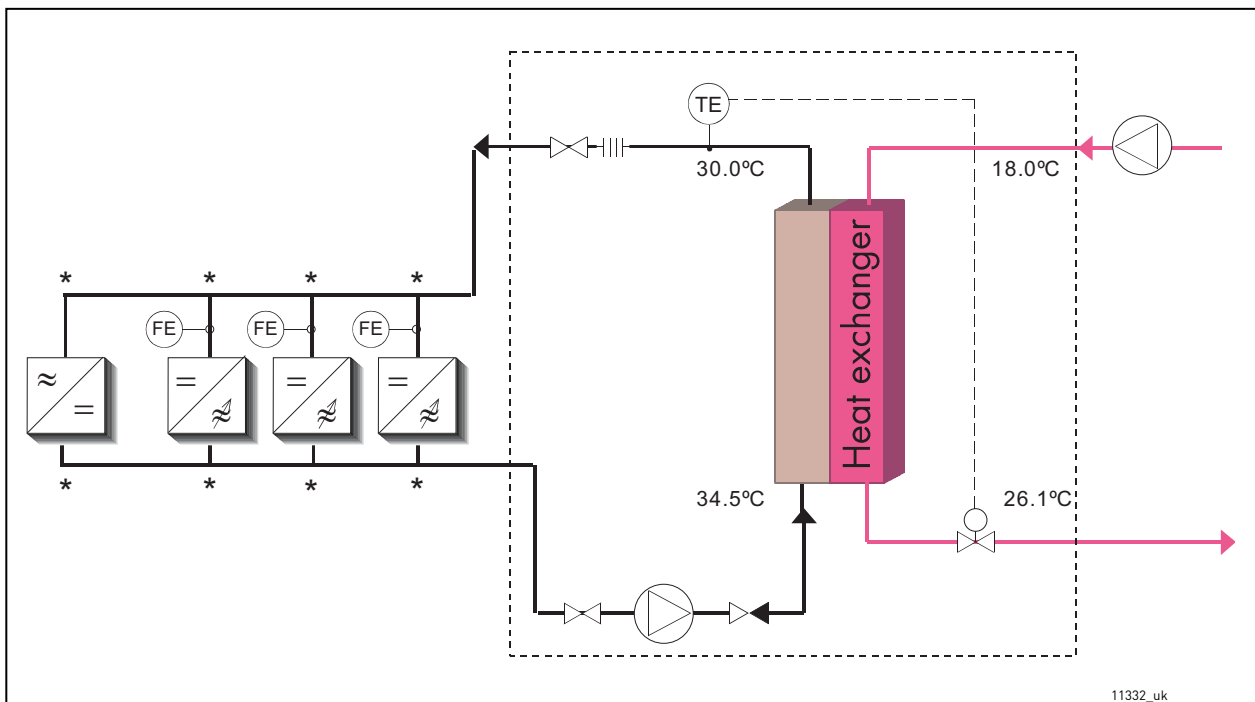

Figure 24. Example of cooling system

We recommend to equip the cooling system with pressure and flow supervision (FE). The flow supervision can be connected to digital input function External fault. If the coolant flow is found too low, the AC drive will be stopped.

The flow supervision and other actuators, e.g. a constant flow valve, are available as options. The options must be mounted at the junction of the main line and the branching line to the element, indicated with an asterisk (*) in the figure above.

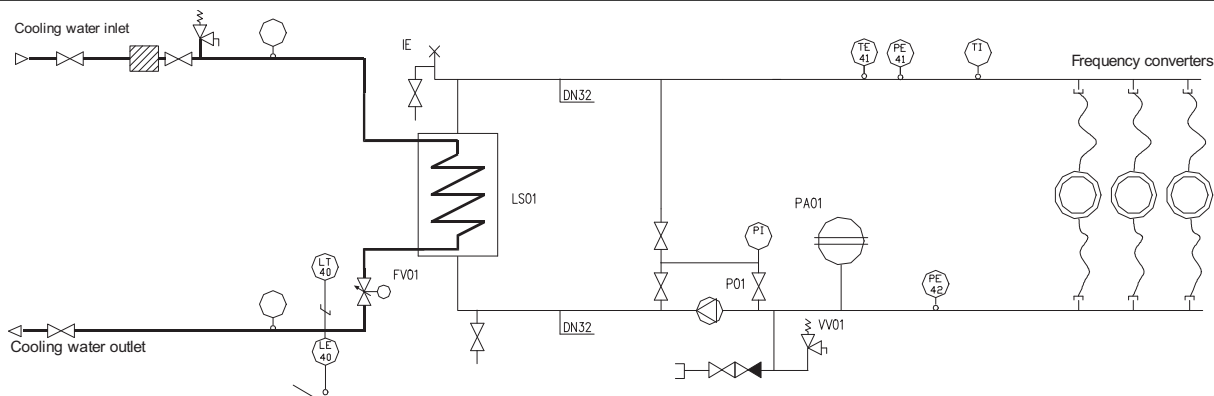

Figure 25. Example: PI-diagram of the cooling system and the connections

In tables below you will find the specifications related to the cooling agent and its circulation. See also Table 9 on page 25.

Table 19. Information about cooling agent and its circulation

Chassis	Min. liquid flow per element (drive) [dm ³ /min]	Nom. liquid flow per element (drive) [dm ³ /min]			Max. liquid flow per element (drive) [dm ³ /min]	Liquid volume/element [l]
	A	A	B	C	A	A
CH3	3 (3)	5 (5)	5.4 (5.4)	5.8 (5.8)	20 (20)	0.11
CH4	8 (8)	10 (10)	11 (11)	12 (12)	20 (20)	0.15
CH5	10 (10)	15 (15)	16 (16)	17 (17)	40 (40)	0.22
CH60	15 (15)	25 (25)	27 (27)	29 (29)	40 (40)	0.38
CH61	15 (15)	25 (25)	27 (27)	29 (29)	40 (40)	0.38
CH62	15 (15)	25 (25)	27 (27)	29 (29)	40 (40)	0.38
CH63	15 (30)	25 (50)	27 (54)	29 (58)	40 (80)	0.38
CH64	15 (45)	25 (75)	27 (80)	29 (86)	40 (120)	0.38
CH72	20 (20)	35 (35)	37 (37)	40 (40)	40 (40)	1.58
CH74	20 (60)	35 (105)	37 (112)	40 (121)	40 (120)	1.58

A = 100% water; B = Water/Glycol mixture 80:20; C = Water/Glycol mixture (60:40)

Min liquid flow = Minimum flow rate to ensure of total venting of the cooling element

Definitions: Nom liquid flow = Flow rate that allows running the drive at lth
 Max liquid flow = If flow rate exceeds max liquid flow, risk of cooling element erosion increases

Liquid ref temperature, input: 30 °C
 Max temperature rise during circulation: 5 °C

NOTE! Unless minimum liquid flow rate is ensured, air pockets may develop in the cooling elements. Automatic or manual de-airing of the cooling system must also be ensured.

The following table will help you to determine the appropriate flows of cooling agent (l/min) with given power losses (see Chapter 4.2).

Table 20. Cooling agent flow rates (l/min) in relation to power loss at certain glycol/water mixture

Power loss [kW]	Glycol/Water ratio					
	100/0	80/20	60/40	40/60	20/80	0/100
1	4.41	3.94	3.58	3.29	3.06	2.87
2	8.82	7.88	7.15	6.58	6.12	5.74
3	13.23	11.82	10.73	9.87	9.18	8.61
4	17.64	15.75	14.31	13.16	12.24	11.48
5	22.05	19.69	17.88	16.45	15.30	14.35

Table 20. Cooling agent flow rates (l/min) in relation to power loss at certain glycol/water mixture

Power loss [kW]	Glycol/Water ratio					
	100/0	80/20	60/40	40/60	20/80	0/100
6	26.46	23.63	21.46	19.74	18.36	17.22
7	30.86	27.57	25.03	23.03	21.42	20.10
8	35.27	31.51	28.61	26.32	24.48	22.97
9	39.68	35.45	32.19	29.61	27.54	25.84
10	44.09	39.38	35.76	32.90	30.60	28.71

5.2.1 CONDENSATION

Condensation on the cooling plate of the VACON® NX Liquid-Cooled drive must be avoided. Therefore, the temperature of the cooling liquid must be kept higher than the temperature of the electrical room. Use the graph below to determine if the drive operating conditions (combination of room temperature, humidity and cooling liquid temperature) are safe, or, to choose the allowed temperature for the cooling liquid.

The conditions are safe when the point is below the respective curve. If not, take adequate precautions by decreasing the room temperature and/or the relative humidity or increase the cooling liquid temperature. Note that increasing the temperature of the cooling liquid above figures in loadability charts decreases the nominal output current of the drive. The below curves are valid at sea level altitude (1013 mbar).

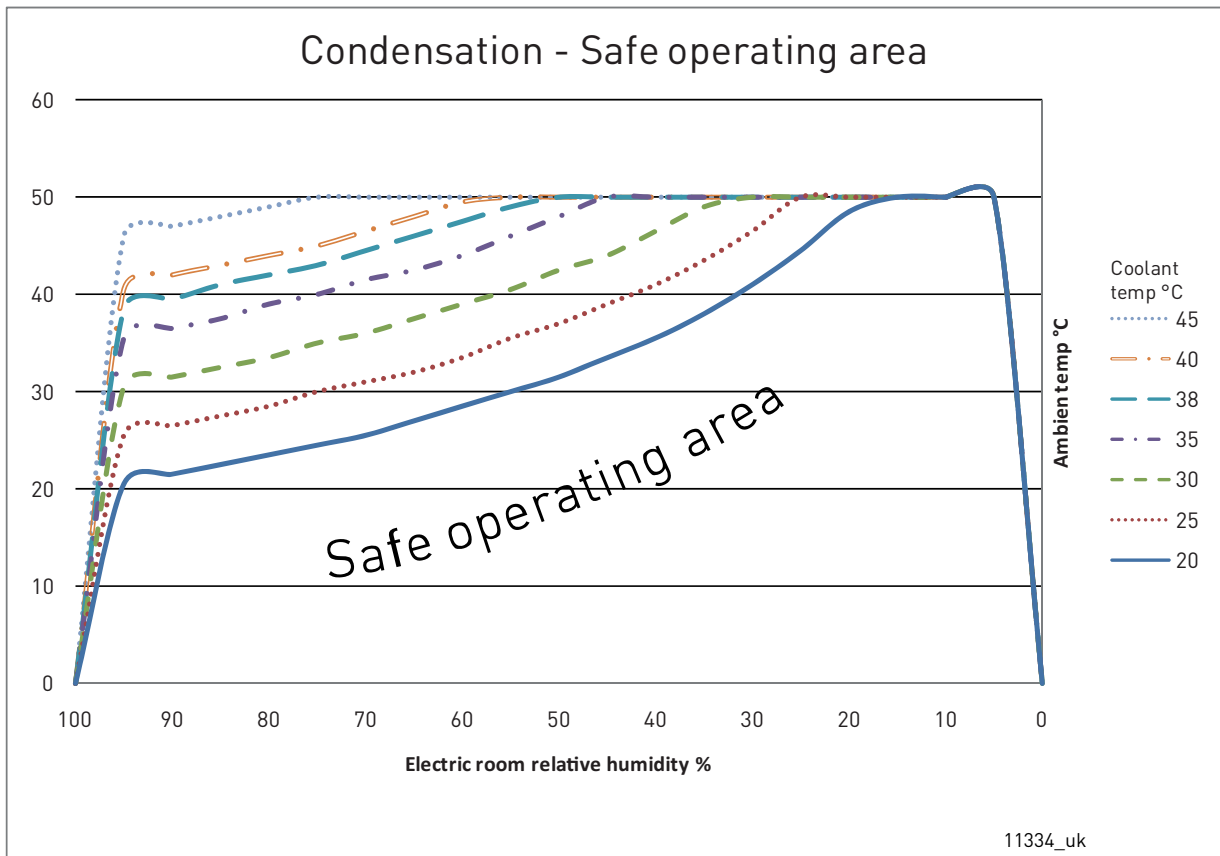

Figure 26. Safe operating conditions in relation to condensation

Example:

If the temperature of the electric room is 30 °C, the relative humidity is 40% and the temperature of the cooling liquid is 20 °C (the lowest curve in Figure 26), then the drive operating conditions are safe.

However, if the room temperature were to rise to 35 °C and the relative humidity to 60%, then the operating conditions of the drive would no longer be safe. In this case, to reach safe operating conditions, the air temperature should be cooled to 28 °C or lower. If it is not possible to lower the room temperature, then the temperature of the cooling liquid should be raised to at least 25 °C.

5.2.2 COOLING SYSTEM CONNECTIONS

The external cooling system must be connected to each one of the cooling elements of the inverter or AC drive.

NOTE! Do not connect the cooling elements in series.

The delivery comprises hoses (Technobel Noir Tricoflex, Art.no 135855) 1.5 m in length and 16 mm in diameter (CH5, CH6, CH7). The hoses are inserted in 1400-mm UL94V0 approved conduits (type HFX40). These hoses have screw type connectors with internal thread. The connection of the hoses is made on the aluminium adapter (external thread) of the cooling element. The customer end thread of the cooling hose is G1/2" male fixed including a Usit-R sealing. When you make the connection of the line hose, avoid any twisting of the hose on the element.



11335_00

Figure 27. Aluminium hose adapters



11336_00

Figure 28. External thread of hose adapter

For all other classes (CH3, CH4), the standard delivery includes fast connectors of type 'Tema', series 1300 or 1900. The fast connectors are available as option also for CH5, CH6, CH7.

Table 21. Liquid connector types (all pressure values at nominal flow)

Chassis	Thread on element (internal) BSPB ^{*)}	Connector type or hose type	Thread (cust.) BSPB ^{**.)}	Max. pressure (entire system)	Pressure loss, (fast connector + element)	Pressure loss, (hoses + element)
CH3	G3/8"	1300NE2 1/4"		6 bar	0.25 bar	
CH4	G3/8"	1300NE2 1/4"		6 bar	0.25 bar	
CH5	G3/4"	Technobel 16*23.5	G1/2"	6 bar		0.2 bar
CH6	G3/4"	Technobel 16*23.5	G1/2"	6 bar	See table below	See table below
CH7	G3/4"	Technobel 16*23.5	G1/2"	6 bar	See table below	See table below

*) Use sealing (e.g. Usit-R Metal washer-rubber sealing) for this type of connection according to ISO standard 228-1

**.) Use sealant or sealing tape for this type of connection

5.2.2.1 Pressure losses

Table 22. Pressure losses; CH6x

CH6x with standard 1.5m hoses and optional fast connectors TEMA							
Volume flow rate (l/min)	Pressure loss; Tema, inflow (bar)	Pressure loss; inflow hose (bar)	Pressure loss; element (bar)	Pressure loss; outflow hose: (bar)	Pressure loss; Tema, outflow (bar)	Pressure loss total (inflow hose, element and outflow hose) (bar)	Pressure loss total (Tema, inflow and outflow hoses and element) (bar)
40.0	0.59	0.30	0.28	0.29	0.51	0.87	1.96
30.0	0.30	0.17	0.16	0.16	0.25	0.49	1.04
20.0	0.10	0.09	0.08	0.07	0.09	0.24	0.43
17.0	0.06	0.07	0.06	0.03	0.07	0.16	0.29

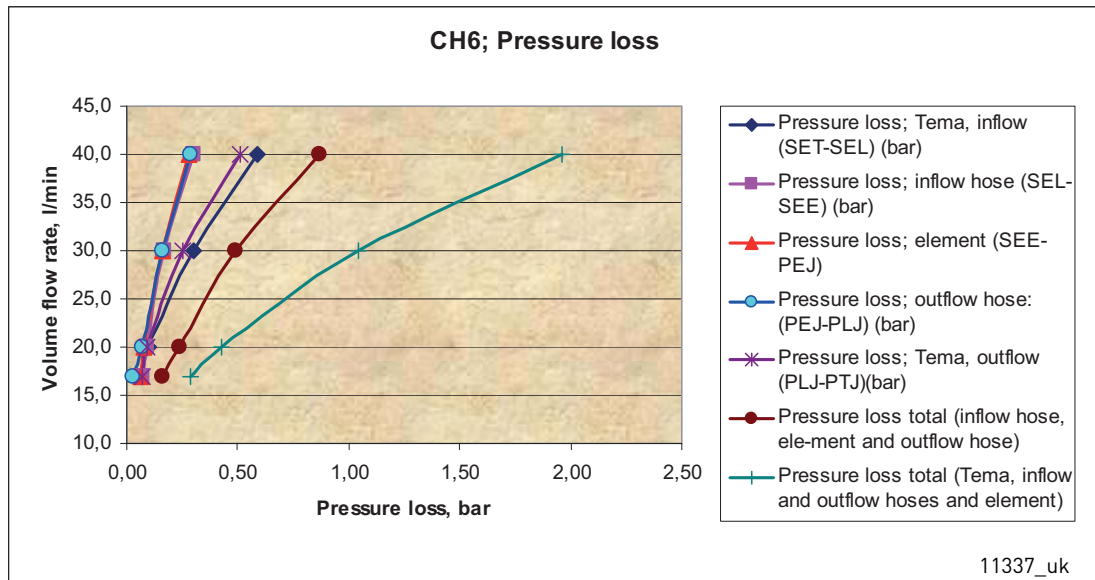

Figure 29. Pressure loss, CH6x

Table 23. Pressure losses; CH7x

CH7x (16) with standard 1.5m hoses and optional fast connectors TEMA							
Volume flow rate (l/min)	Pressure loss; Tema, inflow (bar)	Pressure loss; inflow hose (bar)	Pressure loss; element (bar)	Pressure loss; outflow hose: (bar)	Pressure loss; Tema, outflow (bar)	Pressure loss total (inflow hose, element and outflow hose) (bar)	Pressure loss total (Tema, inflow and outflow hoses and element) (bar)
40.0	0.61	0.30	0.28	0.28	0.50	0.87	1.97
30.0	0.31	0.17	0.17	0.16	0.26	0.50	1.07
20.0	0.11	0.09	0.08	0.07	0.10	0.24	0.44

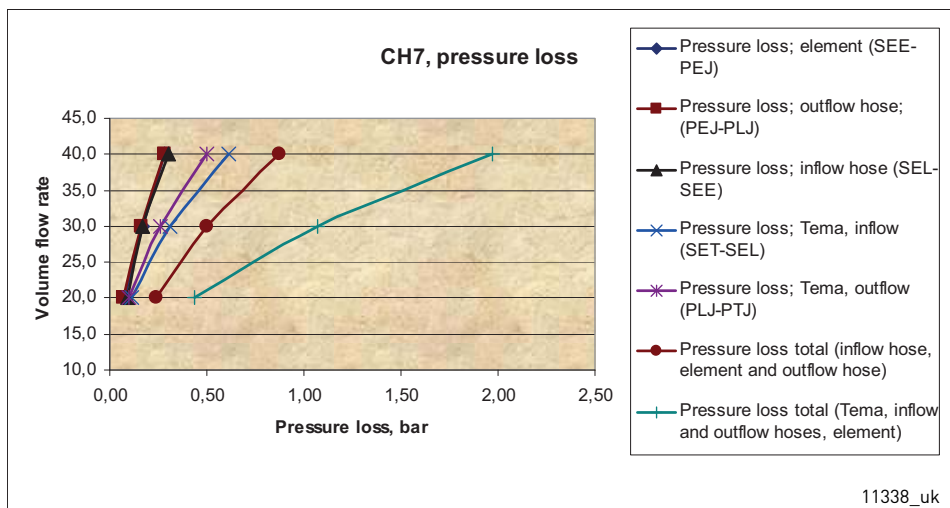

Figure 30. Pressure loss, CH7x

The liquid carrying hoses from the network to the cooling elements of the drive must not be electrically conductive. Risk of electrical shock and device damage! To avoid electrochemical corrosion, it is necessary to add an inhibitor (e.g. Cortec VpCI-649L in the cooling liquid).

The following main line hose materials are allowed for a liquid cooled drive including an aluminum heatsink:

- plastic (PVC)
- rubber (EPDM & NBR only)
- aluminium
- other stainless and acid-proof materials

The following main line hose materials are allowed for a liquid cooled drive including a nickel coated aluminum heatsink:

- plastic (PVC)
- rubber (EPDM & NBR only)
- copper
- aluminium
- brass
- other stainless and acid-proof material

The hoses must tolerate a peak pressure of 30 bar.

Connect the line hose to its counterpart (screw connector or fast connector) on the cooling element of the AC drive/inverter. The coolant inlet connector is the one closer to the mounting plate and the outlet connector the one closer to the face of the drive, see Figure 32. Due to high pressure in the line hose, it is recommended to equip the liquid line with a shut-off valve, which makes the connection easier. In order to prevent water from spraying in the installation room we also recommend to wrap e.g. linters around the connection on installing.

We also recommend to equip the pipe branches to the cooling elements with valves.

5.2.2.2 Installation of flow switch

As stated on page 57, we recommend the installation of flow supervision in the liquid cooling system. You can order the flow switch as an option. The specification of the flow switch as well as notes as concerns its installation are given below.

About the installation

We recommend to mount the flow switch on the inflow side of the system (see Figure 24). Pay attention to the direction of flow. The switch reaches the highest accuracy when it is mounted in horizontal position. If mounted vertically, the mechanical sensor is affected by the Earth’s gravity which reduces the accuracy according to the data given in Table 24.



11339_00

Figure 31. Flow switch: Hose connection, fast connector (electrical), fast connector lock screw, cable seal and clamp

Table 24. Flow switch data

Hose connection	G1/2" female, internal thread ISO228-1
Closing	The switch closes if the flow exceeds 20 l/min.
Switching accuracy: Horizontal installation Vertical installation	-5...+15% (19...23 l/min) ±5% (19...21 l/min)

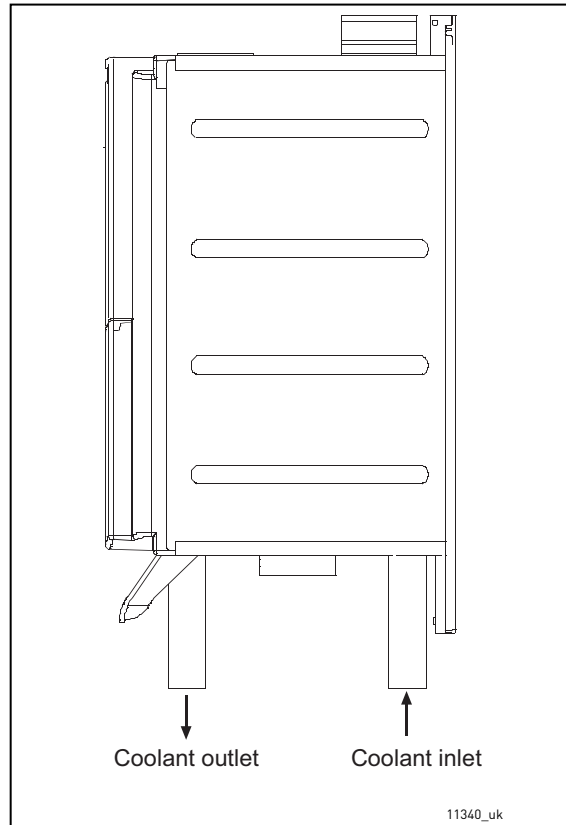

Figure 32. Direction of coolant circulation

5.3 DRIVE DERATING

The tables below state the maximum coolant temperatures for VACON® Liquid-Cooled drives at given switching frequencies. Drive derating is required if the maximum temperatures are exceeded.

NOTE! If the heatsink is nickel-coated you must allow for a 2-degree C derating of values in the tables below.¹⁾ (Temperatures given in parenthesis). This applies only to the two biggest drive sizes of each chassis!

Table 25. Max temperatures of coolant at switching frequency of 3.6 kHz

Supply voltage 400-500 VAC, switching frequency 3.6 kHz			
Chassis	Type	Max coolant temperature [°C] Supply voltage 400 V	Max coolant temperature [°C] Supply voltage 500 V
CH 61	NXP0385_5	47 (45) ¹⁾	43 (41) ¹⁾
CH62	NXP0730_5	40 (38) ¹⁾	37 (35) ¹⁾
CH63	NXP1150_5	38 (36) ¹⁾	36 (34) ¹⁾
CH64	NXP2060_5	44 (42) ¹⁾	42 (40) ¹⁾
CH64	NXP2300_5	42 (40) ¹⁾	40 (38) ¹⁾
CH72	NXP0730_5	42 (40) ¹⁾	40 (38) ¹⁾
CH74	NXP2060_5	37 (35) ¹⁾	34 (32) ¹⁾
CH74	NXP2300_5	37 (35) ¹⁾	34 (32) ¹⁾

Table 26. Max temperatures of coolant at switching frequency of 1.5 kHz

Supply voltage 400-500 VAC, switching frequency 1.5 kHz			
Chassis	Type	Max coolant temperature [°C] Supply voltage 400 V	Max coolant temperature [°C] Supply voltage 500 V
CH61	NXP0385_5	52 (50) ¹⁾	49 (47) ¹⁾
CH62	NXP0730_5	47 (45) ¹⁾	45 (43) ¹⁾
CH63	NXP1150_5	44 (42) ¹⁾	42 (40) ¹⁾
CH64	NXP2060_5	49 (47) ¹⁾	47 (45) ¹⁾
CH64	NXP2300_5	44 (42) ¹⁾	42 (40) ¹⁾
CH72	NXP0730_5	45 (43) ¹⁾	43 (41) ¹⁾
CH74	NXP2060_5	49 (47) ¹⁾	47 (45) ¹⁾
CH74	NXP2300_5	44 (42) ¹⁾	43 (41) ¹⁾

Table 27. Max temperatures of coolant at switching frequency of 3.6 kHz

Supply voltage 525-690 VAC, switching frequency 3.6 kHz			
Chassis	Type	Max coolant temperature [°C] Supply voltage 525 V	Max coolant temperature [°C] Supply voltage 690 V
CH61	NXP0261_6	45 (43) ¹⁾	39 (37) ¹⁾
CH62	NXP0502_6	41 (39) ¹⁾	33 (31) ¹⁾
CH63	NXP0750_6	42 (40) ¹⁾	36 (34) ¹⁾
CH64	NXP1500_6	41 (39) ¹⁾	34 (32) ¹⁾
CH72	NXP0502_6	38 (36) ¹⁾	32 (30) ¹⁾
CH74	NXP1500_6	41 (39) ¹⁾	34 (32) ¹⁾

Table 28. Max temperatures of coolant at switching frequency of 1.5 kHz

Supply voltage 525-690 VAC, switching frequency 1.5 kHz			
Chassis	Type	Max coolant temperature [°C] Supply voltage 525 V	Max coolant temperature [°C] Supply voltage 690 V
CH61	NXP0261_6	54 (52) ¹⁾	51 (49) ¹⁾
CH62	NXP0502_6	52 (50) ¹⁾	47 (45) ¹⁾
CH63	NXP0750_6	53 (51) ¹⁾	50 (48) ¹⁾
CH64	NXP1500_6	52 (50) ¹⁾	47 (45) ¹⁾
CH72	NXP0502_6	51 (49) ¹⁾	46 (44) ¹⁾
CH74	NXP1500_6	52 (50) ¹⁾	48 (46) ¹⁾

Table 29. Max temperatures of coolant

Supply voltage 400-690 VAC			
Chassis	Type	Max coolant temperature [°C] Supply voltage 400 V	Max coolant temperature [°C] Supply voltage 690 V
CH 60	NXN2000_6	43	43

5.4 INPUT CHOKES

The input choke carries out several functions in the VACON® NX Liquid-Cooled AC drive. Connection of the input choke is necessary except if you have a component in your system that performs the same tasks (e.g. a transformer). The input choke is needed as an essential component for motor control, to protect the input and DC-link components against abrupt changes of current and voltage as well as to function as a protection against harmonics. In chasses with multiple parallel line rectifiers (CH74) AC-chokes are required to balance the line current between the rectifiers.

The input chokes are included in the standard delivery of VACON® Liquid-Cooled AC drives (not inverters). However, you can also order your AC drive without the choke.

The VACON® chokes listed below are meant for supply voltages of 400-500 V and 525-690 V.

Table 30. Input choke dimensioning, 6-pulse supply

AC drive types (400—500 VAC)	AC drive types (690 VAC)	Choke type	Thermal current [A]	Nominal inductance [0H] A/B*	Calculated loss [W]
0016...0022	0012...0023	CHK0023N6A0	23	1900	145
0031...0038	0031...0038	CHK0038N6A0	38	1100	170
0045...0061	0046...0062	CHK0062N6A0	62	700	210
0072...0087	0072...0087	CHK0087N6A0	87	480	250
0105...0140	0105...0140	CHK0145N6A0	145	290	380
0168...0261	0170...0261	CHK0261N6A0	261	139/187	460
0300...0385	0325...0385 0820...1180 1850...2340	CHK0400N6A0	400	90/126	610
0460...0520 1370 (CH74)	0416...0502 1300...1500 2700...3100	CHK0520N6A0	520	65/95	810
0590...0650 1640	0590...0650 1700	CHK0650N6A0	650	51/71	890
0730 2060	0750	CHK0750N6A0	750	45/61	970
0820 2300	-	CHK0820N6A0	820	39/53	1020
0920...1030	-	CHK1030N6A0	1030	30/41	1170
1150	-	CHK1150N6A0	1150	26/36	1420
2470...2950		CHK0520N6A0	520	65/95	810
3710		CHK0650N6A0	650	51/71	890
4140		CHK0750N6A0	750	45/61	970
AC drive types written bold italic require three (3) chokes of the designated kind <u>per unit</u> with 6-pulse supply.					

Table 31. Input choke dimensioning, 12-pulse supply

AC drive types (400—500 VAC)	AC drive types (690 VAC)	Choke type (2 chokes needed)	Thermal current [A]	Nominal inductance [OH] A/B*	Calculated loss [W]
0460...0520	0325...0502	CHK0261N6A0	261	139/187	460
0590...0730	0590...0750	CHK0400N6A0	400	90/120	610
0820...1030	0820...1030 1850	CHK0520N6A0	520	65/95	810
1150 2300 2470	1180...1300 2120...2340	CHK0650N6A0	650	51/71	890
1370 2950	1370 2700	CHK0750N6A0	750	45/61	970
1640	1500 3100	CHK0820N6A0	820	39/53	1020
2060 3710	1700	CHK1030N6A0	1030	30/41	1170
4140	-	CHK1150N6A0	1150	26/36	1420

AC drive types written bold italic require two (2) chokes of the designated kind per unit (totally 4).

*Inductances for different supply voltages; A = 400...480 Vac, B = 500...690 Vac.
See page 72.

5.4.1 INSTALLATION OF INPUT CHOKES

There are two types of input choke connection in VACON® NX Liquid-Cooled drives. The two smallest sizes (CH31, CH32; up to 61 A) have terminal block connection whereas bigger sizes use busbar connection. Examples of both connections and the choke dimensions below.

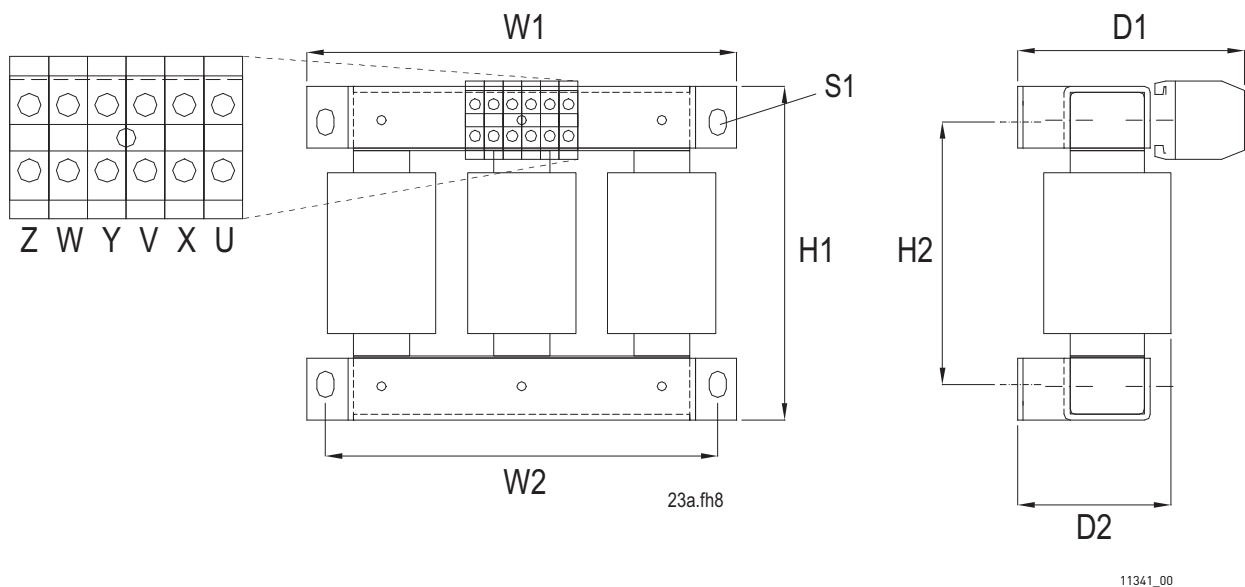
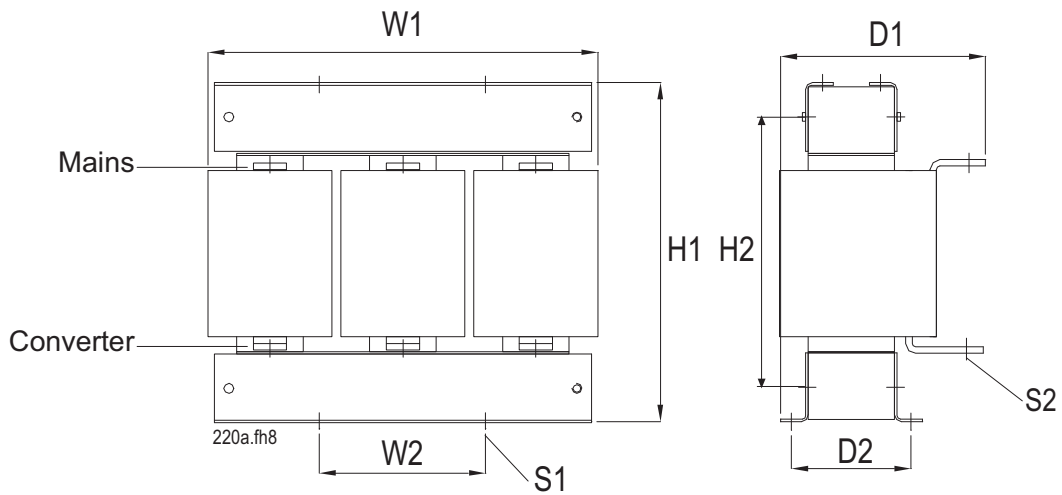

Figure 33. Example of input chokes for VACON® NX Liquid-Cooled. Sizes up to 62 A



11342_uk

Figure 34. Example of input chokes for VACON® NX Liquid-Cooled. Sizes 87 A... 145 A and 590 A

Table 32. Choke dimensions; Sizes 23 A... 145 A and 590 A

Choke type	H1 [mm]	H2 [mm]	W1 [mm]	W2 [mm]	D1 [mm]	D2 [mm]	S1 [mm]	S2 [mm]	Weight [kg]
CHK0023N6A0	178	140	230	210	121	82	9*14 (4pcs)		10
CHK0038N6A0	209	163	270	250	NA	NA	9*14 (6pcs)		15
CHK0062N6A0	213	155	300	280	NA	NA	9*14 (4pcs)		20
CHK0087N6A0	232	174	300	280	170		9*14 (4pcs)	Ø9 (6 pcs)	26
CHK0145N6A0	292	234	300	280	185		9*14 (4pcs)	Ø9 (6 pcs)	37
CHK0590N6A0	519		394	316	272	165	10*35 (4pcs)	Ø11 (6 pcs)	125

Always connect the supply cables to the choke terminals marked with #1 (see Figure 35). Choose the AC drive connection according to the table below:

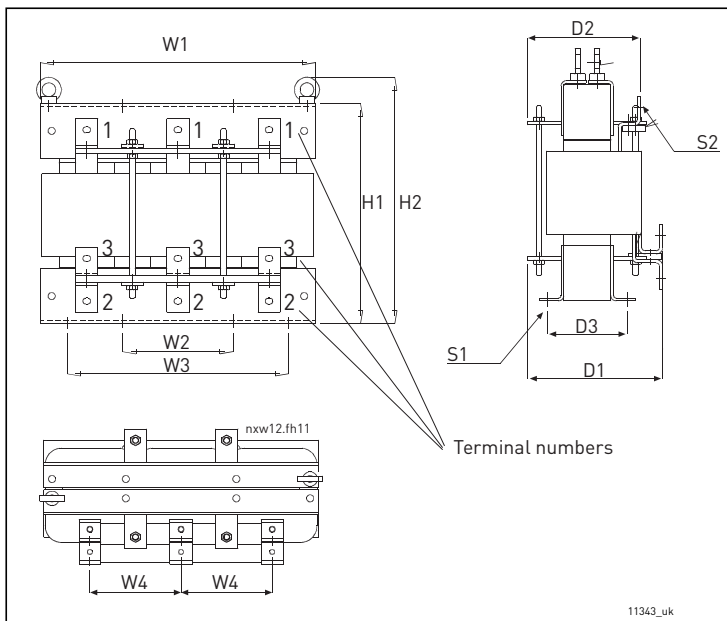

Table 33.

Supply voltage	AC drive connection (terminal no.)
400-480 Vac	2
500 Vac	3
525-690 Vac	3

Figure 35. Example of input chokes for VACON® NX Liquid-Cooled. Sizes 261 A... 1150 A

Table 34. Choke dimensions; Sizes 261 A... 1150 A

Choke type	H1 [mm]	H2 [mm]	W1 [mm]	W2 [mm]	W3 [mm]	W4 [mm]	D1 [mm]	D2 [mm]	D3 [mm]	S1	S2 Ø	Weight [kg]
CHK0261N6A0	319	357	354	150	275	120	230	206	108	9*14 (8 pcs)	9*14 (9 pcs)	53
CHK0400N6A0	383	421	350	150	275	120	262	238	140	9*14 (8 pcs)	11*15 (9 pcs)	84
CHK0520N6A0	399	446	497	200	400	165	244	204	145	Ø13 (8 pcs)	11*15 (9 pcs)	115
CHK0650N6A0	449	496	497	200	400	165	244	206	145	Ø13 (8 pcs)	11*15 (9 pcs)	130
CHK0750N6A0	489	527	497	200	400	165	273	231	170	Ø13 (8 pcs)	13*18 (9 pcs)	170
CHK0820N6A0	491	529	497	200	400	165	273	231	170	Ø13 (8 pcs)	13*18 (9 pcs)	170
CHK1030N6A0	630	677	497	200	400	165	307	241	170	Ø13 (8 pcs)	13*18 (36 pcs)	213
CHK1150N6A0	630	677	497	200	400	165	307	241	170	Ø13 (8 pcs)	13*18 (36 pcs)	213

If you have ordered the input chokes for VACON® NX Liquid-Cooled separately pay attention to the following instructions:

1. Protect the chokes from dripping water. You may even need to use plexiglass for protection because jets of water may occur when working with the connections.
2. Connection of cables:

Types CHK0023N6A0, CHK0038N6A0, CHK0062N6A0 (chokes with terminal blocks)

The terminals are marked with letters U,V, W and X,Y and Z in such an order, however, that terminals U and X, V and Y as well as W and Z form pairs of which one is an input and the other an output. Furthermore, terminals U,V and W must all be used as either input or output. The same applies to terminals X, Y and Z. See Figure 33.

Example: If you connect the mains cable of one phase to terminal X, the other two phases must be connected to Y and Z. Accordingly, the choke output cables are connected to their corresponding input pairs: phase 1 → U, phase 2 → V and phase 3 → W.

Other types (chokes with busbar connection)

Connect the mains cables to the upper busbar connectors (see Figure 34 and Figure 35) with bolts. The cables to the AC drive are bolted to the lower connectors. See Table 32 and Table 34 for bolt sizes.

6. ELECTRICAL CABLING AND CONNECTIONS

6.1 POWER UNIT

How the power connections of VACON[®] NX Liquid-Cooled units are implemented depends on the size of the unit. The smallest VACON[®] NX Liquid-Cooled unit (CH3) has terminal blocks for the connections. In all other units, the connection is established using cables and cable clips or bolting the busbars together.

The main circuit diagrams of each VACON[®] NX Liquid-Cooled drive chassis you will find in Appendix 2 on page 194.

6.1.1 POWER CONNECTIONS

Use cables with heat resistance of at least +90 °C. The cables and the fuses must be sized according to the drive nominal OUTPUT current that you can find on the rating plate. Sizing according to the output current is recommended because the drive input current never significantly exceeds the output current. Installation of cables according to UL regulations is presented in Chapter 6.1.6.

In chassis CH5 and greater, the field cables (both motor and mains) must be connected to a specific cable connection block (optional equipment). However, inside a switchgear, the cable connection can be made directly to the drive.

VACON[®] Liquid-Cooled NX_8 inverter units must be equipped with a du/dt- or sine-filter.

Table 41 shows the minimum sizes of the Cu-cables and the corresponding aR fuse sizes.

If the motor temperature protection of the drive (see VACON[®] NX All in One Application Manual) is used as an overload protection, the cable must be chosen accordingly. If three or more cables are used in parallel each cable requires a separate overload protection.

These instructions apply only to cases with one motor and one cable connection from the AC drive or inverter to the motor. In any other case, ask the factory for more information.

6.1.1.1 Mains cable

The mains cables of the size CH31 are connected to terminal blocks [see Figure 6] whereas busbar connection is used for greater sizes, see drawings in Chapter 5.1.2.2. Mains cable type for EMC level N in Table 35.

6.1.1.2 Motor cable

In order to avoid current sharing disbalance it is imperative to use symmetrical motor cables. We also recommends to always use shielded cable whenever possible.

The motor cables of the size CH31 are connected to terminal blocks (see Figure 6) whereas busbar connection is used for greater sizes, see drawings on on Chapter 5.1.2.2. Motor cable type for EMC level N in Table 35. Ask factory for more information on the use of ferrite cores with the motor cable in order to protect the motor bearings against motor bearing currents.

For information on control cables see Chapter 6.2.2.1 and Table 35.

Table 35. Cable types required to meet standards

Cable type	Level N/T
Mains cable	1
Motor cable	1
Control cable	4

- Power cable intended for fixed installation and the specific
- 1 = mains voltage. Symmetrical shielded cable recommended. (NKCABLES/MCMK or similar recommended)
- 4 = Screened cable equipped with compact low-impedance shield (NKCABLES /JAMAK, SAB/ÖZCuY-O or similar).

6.1.1.3 Motor cable data

Table 36. Motor cable sizes, 400–500 V

Chassis	Type	I _{th}	Motor cable Cu [mm ²]	Terminal cable size		Max. number of cables/ Bolt size
				Main terminal [mm ²], max.	Earth terminal [mm ²]	
CH3	0016_5	16	3*2.5+2.5	50	1–10	(Terminal block)
CH3	0022_5	22	3*4+4	50	1–10	(Terminal block)
CH3	0031	31	3*6+6	50	1–10	(Terminal block)
CH3	0038_5 0045_5	38–45	3*10+10	50 Cu 50 Al	6–35	(Terminal block)
CH3	0061_5	61	3*16+16	50 Cu 50 Al	6–35	(Terminal block)
CH4	0072_5	72	3*25+16	50 Cu 50 Al	6–70	1/M8
CH4	0087_5	87	3*35+16	50 Cu 50 Al	6–70	1/M8
CH4	0105_5	105	3*50+25	50 Cu 50 Al	6–70	1/M8
CH4	0140_5	140	3*70+35	95 Cu/Al	25–95	1/M8
CH5	0168_5	168	3*95+50	185 Cu/Al	25–95	2/M10
CH5	0205_5	205	3*150+70	185 Cu/Al	25–95	2/M10
CH5	0261_5	261	3*185+95	185 Cu/Al	25–95	2/M10
CH61	0300_5	300	2*(3*120+70)	*	25–185	2/M12
CH61	0385_5	385	2*(3*120+70)	*	25–185	2/M12
CH62/72	0460_5	460	2*(3*150+70)	**	25–185	4/M12
CH62/72	0520_5	520	2*(3*185+95)	**	25–185	4/M12

Table 36. Motor cable sizes, 400–500 V

Chassis	Type	I _{th}	Motor cable Cu [mm ²]	Terminal cable size		Max. number of cables/ Bolt size
				Main terminal [mm ²], max.	Earth terminal [mm ²]	
CH62/72	0590_5 0650_5	590 650	3*(3*150+70)	**	25–185	4/M12
CH62/72	0730_5	730	3*(3*150+70)	**	25–185	4/M12
CH63	0820_5	820	3*(3*185+95)	**	****	8/M12
CH63	0920_5	920	4*(3*185+95)	**	****	8/M12
CH63	1030_5	1030	4*(3*185+95)	**	****	8/M12
CH63	1150_5	1150	5*(3*185+95)	**	***	8/M12
CH64	1370_5	1370	5*(3*185+95)	**	***	8/M12
CH64	1640_5	1640	6*(3*185+95)	**	***	8/M12
CH64	2060_5	2060	7*(3*185+95)	**	***	8/M12
CH64	2300_5	2300	8*(3*185+95)	**	***	8/M12
CH74 ¹⁾	1370_5	1370	5*(3*185+95)	**	***	4/M12
CH74 ¹⁾	1640_5	1640	6*(3*185+95)	**	***	4/M12
CH74 ¹⁾	2060_5	2060	7*(3*185+95)	**	***	4/M12
CH74 ¹⁾	2300_5	2300	8*(3*185+95)	**	***	4/M12

¹⁾ Due to insufficient number of terminal bolt connections for required amount of cables, the cabinet must be equipped with an external flexible cable connection block at both mains and motor ends if stiff cable type is used.

Units with 6-pulse supply

Note that all other sizes have 3 input terminals except for size CH74, which has 9 input terminals.

Units with 12-pulse supply

12-pulse supply can be used with drives of sizes CH72 and CH74. The number of input terminals for both is 6.

If 12-pulse supply is used, pay also attention to the fuse selection, see page 82 and page 83.

See the tightening torques of bolts in Table 40.

Table 37. Motor cable sizes, 525–690 V

Chassis	Type	I _{th}	Motor cable Cu [mm ²]	Terminal cable size		Max. number of cables/ Bolt size
				Main terminal [mm ²], max	Earth terminal [mm ²]	
CH61	0170_6	170	3*95+50	185 Cu/Al	25–95	2/M12
CH61	0208_6	208	3*150+70	185 Cu/Al	25–95	2/M12
CH61	0261_6	261	3*185+95	185 Cu/Al 2	25–95	2/M12

Table 37. Motor cable sizes, 525—690 V

Chassis	Type	I _{th}	Motor cable Cu [mm ²]	Terminal cable size		Max. number of cables/ Bolt size
				Main terminal [mm ²], max	Earth terminal [mm ²]	
CH62/72	0325_6	325	2*(3*95+50)	**	25—185	4/M12
CH62/72	0385_6	385	2*(3*120+70)	**	25—185	4/M12
CH62/72	0416_6	416	2*(3*150+70)	**	25—185	4/M12
CH62/72	0460_6	460	2*(3*185+95)	**	25—185	4/M12
CH62/72	0502_6	502	2*(3*185+95)	**	25—185	4/M12
CH63	0590_6	590	3*(3*150+70)	**	***	8/M12
CH63	0650_6	650	3*(3*150+70)	**	***	8/M12
CH63	0750_6	750	3*(3*185+95)	**	***	8/M12
CH74 ¹⁾	0820_6	820	4*(3*150+70)	**	***	4/M12
CH74 ¹⁾	0920_6	920	4*(3*185+95)	**	***	4/M12
CH74 ¹⁾	1030_6	1030	4*(3*185+95)	**	***	4/M12
CH74 ¹⁾	1180_6	1180	5*(3*185+95)	**	***	4/M12
CH74 ¹⁾	1300_6	1300	5*(3*185+95)	**	***	4/M12
CH74 ¹⁾	1500_6	1500	6*(3*185+95)	**	***	4/M12
CH74 ¹⁾	1700_6	1700	6*(3*240+120)	**	***	4/M12

¹⁾Due to insufficient number of terminal bolt connections for required amount of cables, the cabinet must be equipped with an external flexible cable connection block at both mains and motor ends if stiff cable type is used.

* = Number of bolt connections 2

** = Number of bolt connections 4

*** = Three grounding terminals per mounting plate, see Chapter 6.1.7.

**** = Two grounding terminals per mounting plate, see Chapter 6.1.7.

See the tightening torques of bolts in Table 40.

6.1.1.4 Mains cable data for AC drives

Table 38. Mains cable sizes for AC drives, 400–500 V

Chassis	Type	I _{th}	Mains cable Cu [mm ²]	Terminal cable size		Max. number of cables/ Bolt size
				Main terminal [mm ²], max	Earth terminal [mm ²]	
CH3	0016_5	16	3*2.5+2.5	50	1–10	(Terminal block)
CH3	0022_5	22	3*4+4	50	1–10	(Terminal block)
CH3	0031	31	3*6+6	50	1–10	(Terminal block)
CH3	0038_5 0045_5	38–45	3*10+10	50 Cu 50 Al	6–35	(Terminal block)
CH3	0061_5	61	3*16+16	50 Cu 50 Al	6–35	(Terminal block)
CH4	0072_5	72	3*25+16	50 Cu 50 Al	6–70	1/M8
CH4	0087_5	87	3*35+16	50 Cu 50 Al	6–70	1/M8
CH4	0105_5	105	3*50+25	50 Cu 50 Al	6–70	1/M8
CH4	0140_5	140	3*70+35	95 Cu/Al	25–95	1/M8
CH5	0168_5	168	3*95+50	185 Cu/Al	25–95	2/M10
CH5	0205_5	205	3*150+70	185 Cu/Al	25–95	2/M10
CH5	0261_5	261	3*185+95	185 Cu/Al	25–95	2/M10
CH61	0300_5	300	2*(3*120+70)	300 Cu/Al	25–185	2/M12
CH61	0385_5	385	2*(3*120+70)	300 Cu/Al	25–185	2/M12
CH72/CH72	0460_5	460	2*(3*150+70)	300 Cu/Al	25–185	2 (or 4)/M12
CH72/CH72	0520_5	520	2*(3*185+95)	300 Cu/Al	25–185	2 (or 4)/M12
CH72	0590_5 0650_5	590 650	2*(3*240+120)	300 Cu/Al	25–185	2/M12
CH72	0590_5 0650_5 0730_5	590 650 730	4*(3*95+50)	300 Cu/Al	25–185	4/M12
CH72 ¹⁾	0730_5	730	3*(3*150+70)	300 Cu/Al	25–185	2/M12
CH63 ¹⁾	0820_5	820	3*(3*185+95)	300 Cu/Al	***	2/M12
CH63 ¹⁾	0920_5 1030_5	920 1030	4*(3*185+95)	300 Cu/Al	***	2/M12
CH63 ¹⁾	1150_5	1150	4*(3*240+120)	300 Cu/Al	***	2/M12
CH74/ CH74 ¹⁾	1370_5	1370	6*(3*150+70)	300 Cu/Al	***	6 (or 4)/M12
CH74/ CH74 ¹⁾	1640_5	1640	6*(3*185+95)	300 Cu/Al	***	6 (or 4)/M12
CH74 ¹⁾	2060_5	2060	9*(3*150+70)	300 Cu/Al	***	6/M12

Table 38. Mains cable sizes for AC drives, 400—500 V

Chassis	Type	I _{th}	Mains cable Cu [mm ²]	Terminal cable size		Max. number of cables/ Bolt size
				Main terminal [mm ²], max	Earth terminal [mm ²]	
CH74 ¹⁾	2060_5	2060	8*(3*185+95)	300 Cu/Al	***	4/M12
CH74 ¹⁾	2300_5	2300	9*(3*185+95)	300 Cu/Al	***	6/M12

¹⁾Due to insufficient number of terminal bolt connections for required amount of cables, the cabinet must be equipped with an external flexible cable connection block at both mains and motor ends if stiff cable type is used.

Data in *Italic* refer to drives with 12-pulse supply.

Units with 6-pulse supply

Note that all other sizes have 3 input terminals except for size CH74, which has 9 input terminals. CH74 cables must be connected symmetrically between 3 parallel connected rectifiers in each phase.

Units with 12-pulse supply

12-pulse supply can be used with drives of sizes CH72 and CH74. The number of input terminals for both is 6.

If 12-pulse supply is used, pay also attention to the fuse selection, see page 82 and page 83.

See the tightening torques of bolts in Table 40.

Table 39. Mains cable sizes, 525—690 V

Chassis	Type	I _{th}	Mains cable Cu [mm ²]	Terminal cable size		Max. number of cables/ Bolt size
				Main terminal [mm ²], max.	Earth terminal [mm ²]	
CH61	0170_6	170	3*95+50	185 Cu/Al	25—95	2/M12
CH61	0208_6	208	3*150+70	185 Cu/Al	25—95	2/M12
CH61	0261_6	261	3*185+95	185 Cu/Al 2	25—95	2/M12
CH72/CH72	0325_6	325	2*(3*95+50)	300 Cu/Al	25—185	2 (or 4)/M12
CH72/CH72	0385_6	385	2*(3*120+70)	300 Cu/Al	25—185	2 (or 4)/M12
CH72/CH72	0416_6	416	2*(3*150+70)	300 Cu/Al	25—185	2 (or 4)/M12
CH72/CH72	0460_6	460	2*(3*185+95)	300 Cu/Al	25—185	2 (or 4)/M12
CH72/CH72	0502_6	502	2*(3*185+95)	300 Cu/Al	25—185	2 (or 4)/M12
CH63	0590_6 0650_6	590 650	2*(3*240+120)	300 Cu/Al	****	2/M12
CH63 ¹⁾	0750_6	750	3*(3*185+95)	300 Cu/Al	****	2/M12
CH74	0820_6	820	3*(3*185+95)	300 Cu/Al	***	6/M12
CH74	0820_6	820	4*(3*150+70)	300 Cu/Al	***	4/M12
CH74	0920_6	920	3*(3*240+120)	300 Cu/Al	***	6/M12
CH74	0920_6	920	4*(3*185+95)	300 Cu/Al	***	4/M12
CH74	1030_6	1030	6*(3*95+50)	300 Cu/Al	***	6/M12

Table 39. Mains cable sizes, 525—690 V

Chassis	Type	I _{th}	Mains cable Cu [mm ²]	Terminal cable size		Max. number of cables/ Bolt size
				Main terminal [mm ²], max.	Earth terminal [mm ²]	
CH74	1030_6	1030	4*(3*185+95)	300 Cu/Al	***	4/M12
CH74	1180_6	1180	6*(3*120+95)	300 Cu/Al	***	6/M12
CH74	1180_6 1300_6	1180 1300	4*(3*240+120)	300 Cu/Al	***	4/M12
CH74	1300_6	1300	6*(3*150+95)	300 Cu/Al	***	6/M12
CH74	1500_6	1500	6*(3*185+95)	300 Cu/Al	***	6/M12
CH74 ¹⁾	1500_6	1500	6*(3*185+95)	300 Cu/Al	***	4/M12
CH74	1700_6	1700	6*(3*240+120)	300 Cu/Al	***	6/M12
CH74 ¹⁾	1700_6	1700	6*(3*240+120)	300 Cu/Al	***	4/M12

¹⁾Due to insufficient number of terminal bolt connections for required amount of cables, the cabinet must be equipped with an external flexible cable connection block at both mains and motor ends if stiff cable type is used.

Data in *Italic* refer to drives with 12-pulse supply.

Units with 6-pulse supply

Note that all other sizes have 3 input terminals except for size CH74, which has 9 input terminals.

Units with 12-pulse supply

12-pulse supply can be used with drives of sizes CH72 and CH74. The number of input terminals for both is 6.

If 12-pulse supply is used, pay also attention to the fuse selection, see page 82 and page 83.

See the tightening torques of bolts in Table 40.

Table 40. Tightening torques of bolts

Bolt	Tightening torque [Nm]	Max. inward thread length [mm]
M8	20	10
M10	40	22
M12	70	22
Grounding bolt (see page 91)	13.5	-

We recommend a low-impedance grounding of the motor cable shield for better performance.

Because of several possible cable installations and environmental conditions, it is very important to consider local regulations and the IEC/EN standards.

6.1.1.5 Cable selection and unit installation in accordance with the UL standards

To meet the UL (Underwriters Laboratories) regulations, use a UL-approved copper cable with a minimum heat-resistance of +90 °C to meet the requirements.

Use Class 1 wire only.

The units are suitable for use on a circuit capable of delivering not more than 100,000 rms symmetrical amperes, 600 V maximum, when protected by J, L or T Class fuses.

Integral solid state short circuit protection does not provide branch circuit protection. Branch circuit protection must be provided in accordance with the National Electric Code and any additional local codes. Branch circuit protection provided by fuses only.

6.1.2 DRIVE PROTECTION – FUSES

In order to protect the drive from short-circuits and excessive loads, input line fuses must be used. The warranty becomes void if the drive is not equipped with appropriate fuses.

Depending on the drive configuration, the following types of fuse protection are recommended:

AC drive with AC supply:

Always protect the drive with fast-acting input line fuses for short-circuit protection. Also pay attention to protection of cables!

Common DC bus:

- Inverter units: Choose fuse protection according to Table 43 and Table 44.
- Active Front End (AFE) units: Choose DC fuses according to Table 43 and Table 44; Appropriate fuses for the AC supply are listed in Table 62 and Table 63, see Chapter 10.
- Inverter units connected to AFE units: Choose fuses for AC supply according to Table 62 and Table 63; **NOTE!** Protect each inverter unit with fuses according to Table 43 and Table 44.

DC links interconnected (e.g. 2*CH74)

In case interconnection of DC links is required, contact the manufacturer.

Brake chopper unit

See Chapter 11.

6.1.3 FUSE SIZES

The fuse sizing in the tables below is based on Ferraz aR fuses. We primarily recommend you to use these fuses or corresponding Bussman aR fuses (see Appendix 3 on page 196). Sufficient protection against short-circuit cannot be guaranteed if other fuse types are used. Furthermore, equation of the fuse values given in the tables below with those of other fuse manufacturers is not allowed. In case you wish to use fuses of other fuse manufacturers, contact your nearest distributor.



6.1.3.1 AC drives

Table 41. Fuse sizes for VACON® NX Liquid-Cooled (500 V) AC drives

Chassis	Type	I _{th} [A]	Fuse size	DIN43620	DIN43653	TTF	Fuse U _n [V]	Fuse I _n [A]	Qty. of fuses per drive 3~/6~
				aR fuse catalog nr.	aR fuse catalog nr.	aR fuse catalog nr.			
CH3	0016	16	DIN000	NH000UD69V40PV	DN00UB69V40L	PC30UD69V50TF	690	40/50 ¹	3
CH3	0022	22	DIN000	NH000UD69V40PV	DN00UB69V40L	PC30UD69V50TF	690	40/50 ¹	3
CH3	0031	31	DIN000	NH000UD69V63PV	DN00UB69V63L	PC30UD69V63TF	690	63	3
CH3	0038	38	DIN000	NH000UD69V100PV	DN00UB69V100L	PC30UD69V100TF	690	63	3
CH3	0045	45	DIN000	NH000UD69V100PV	DN00UB69V100L	PC30UD69V100TF	690	100	3
CH3	0061	61	DIN00	NH00UD69V125PV	DN00UB69V125L	PC30UD69V125TF	690	100	3
CH4	0072	72	DIN00	NH00UD69V200PV	DN00UB69V200L	PC30UD69V200TF	690	200	3
CH4	0087	87	DIN00	NH00UD69V200PV	DN00UB69V200L	PC30UD69V200TF	690	200	3
CH4	0105	105	DIN00	NH00UD69V200PV	DN00UB69V200L	PC30UD69V200TF	690	200	3
CH4	0140	140	DIN1	NH1UD69V315PV	PC30UD69V315A	PC30UD69V315TF	690	200	3
CH5	0168	168	DIN1	NH1UD69V315PV	PC30UD69V315A	PC30UD69V315TF	690	400	3
CH5	0205	205	DIN1	NH1UD69V400PV	PC30UD69V400A	PC30UD69V400TF	690	400	3
CH5	0261	261	DIN2	NH2UD69V500PV	PC31UD69V500A	PC31UD69V500TF	690	400	3
CH61	0300	300	DIN2	NH2UD69V700PV	PC31UD69V700A	PC31UD69V700TF	690	700	3
CH61	0385	385	DIN2	NH2UD69V700PV	PC31UD69V700A	PC31UD69V700TF	690	700	3
CH72	0460	460	DIN3	NH3UD69V1000PV	PC33UD69V1000A	PC33UD69V1000TF	690	1000	3
<i>CH72²</i>	<i>0460</i>	<i>460</i>	<i>DIN2</i>	<i>NH2UD69V500PV</i>	<i>PC31UD69V500A</i>	<i>PC31UD69V500TF</i>	<i>690</i>	<i>700</i>	<i>6</i>
CH72	0520	520	DIN3	NH3UD69V1000PV	PC33UD69V1000A	PC33UD69V1000TF	690	1000	3
<i>CH72²</i>	<i>0520</i>	<i>520</i>	<i>DIN2</i>	<i>NH2UD69V500PV</i>	<i>PC31UD69V500A</i>	<i>PC31UD69V500TF</i>	<i>690</i>	<i>700</i>	<i>6</i>
CH72	0590	590	DIN3	PC73UB69V1100PA	PC33UD69V1100A	PC33UD69V1100TF	690	1000	3
<i>CH72²</i>	<i>0590</i>	<i>590</i>	<i>DIN2</i>	<i>NH2UD69V700PV</i>	<i>PC31UD69V700A</i>	<i>PC31UD69V700TF</i>	<i>690</i>	<i>700</i>	<i>6</i>
CH72	0650	650	DIN3	PC73UB69V1250PA	PC33UD69V1250A	PC33UD69V1250TF	690	1250	3
<i>CH72²</i>	<i>0650</i>	<i>650</i>	<i>DIN2</i>	<i>NH2UD69V700PV</i>	<i>PC31UD69V700A</i>	<i>PC31UD69V700TF</i>	<i>690</i>	<i>700</i>	<i>6</i>
CH72	0730	730	DIN3	PC73UB69V1250PA	PC33UD69V1250A	PC33UD69V1250TF	690	1250	3
<i>CH72²</i>	<i>0730</i>	<i>730</i>	<i>DIN2</i>	<i>NH2UD69V700PV</i>	<i>PC31UD69V700A</i>	<i>PC31UD69V700TF</i>	<i>690</i>	<i>700</i>	<i>6</i>
CH63	0820	820	DIN3	NH3UD69V800PV	PC32UD69V800A	PC32UD69V800TF	690	800	6
CH63	0920	920	DIN3	NH3UD69V1000PV	PC33UD69V1000A	PC33UD69V1000TF	690	800	6
CH63	1030	1030	DIN3	NH3UD69V1000PV	PC33UD69V1000A	PC33UD69V1000TF	690	1000	6
CH63	1150	1150	DIN3	PC73UB69V1100PA	PC33UD69V1100A	PC33UD69V1100TF	690	1000	6
CH74	1370	1370	DIN3	NH3UD69V1000PV	PC33UD69V1000A	PC33UD69V1000TF	690	1000	9
<i>CH74²</i>	<i>1370</i>	<i>1370</i>	<i>DIN3</i>	<i>PC73UB69V1250PA</i>	<i>PC33UD69V1250A</i>	<i>PC73UB69V13CTF</i>	<i>690</i>	<i>800</i>	<i>6</i>
CH74	1640	1640	DIN3	NH3UD69V1000PV	PC33UD69V1000A	PC33UD69V1000TF	690	1000	9
<i>CH74²</i>	<i>1640</i>	<i>1640</i>	<i>DIN3</i>	<i>NH3UD69V800PV</i>	<i>PC32UD69V800A</i>	<i>PC32UD69V800TF</i>	<i>690</i>	<i>800</i>	<i>12</i>
CH74	2060	2060	DIN3	PC73UB69V1250PA	PC33UD69V1250A	PC33UD69V1250TF	690	1250	9
<i>CH74²</i>	<i>2060</i>	<i>2060</i>	<i>DIN3</i>	<i>NH3UD69V1000PV</i>	<i>PC33UD69V1000A</i>	<i>PC33UD69V1000TF</i>	<i>690</i>	<i>1000</i>	<i>12</i>
CH74	2300	2300	DIN3	PC73UB69V1250PA	PC33UD69V1250A	PC33UD69V1250TF	690	1250	9
<i>CH74²</i>	<i>2300</i>	<i>2300</i>	<i>DIN3</i>	<i>PC73UB69V1100PA</i>	<i>PC33UD69V1100A</i>	<i>PC33UD69V1100TF</i>	<i>690</i>	<i>1000</i>	<i>12</i>

¹ Fuse current (I_n) 50A for TTF aR fuse.

² Data in *Italic* refer to drives with 12-pulse supply

Table 42. Fuse sizes for VACON® NX Liquid-Cooled (690 V) AC drives

Chassis	Type	I _{th} [A]	Fuse size	DIN43620	DIN43653	TTF	Fuse U _n [V]	Fuse I _n [A]	Qty. of fuses per drive 3~/6~
				aR fuse part nr.	aR fuse part nr.	aR fuse part nr.			
CH61	0170	170	DIN1	NH1UD69V315PV	PC30UD69V315A	PC30UD69V315TF	690	315	3
CH61	0208	208	DIN1	NH1UD69V400PV	PC30UD69V400A	PC30UD69V400TF	690	400	3
CH61	0261	261	DIN2	NH2UD69V500PV	PC31UD69V500A	PC31UD69V500TF	690	500	3
CH72	0325	325	DIN2	NH2UD69V700PV	PC31UD69V700A	PC31UD69V700TF	690	700	3
<i>CH72¹</i>	<i>0325</i>	<i>325</i>	<i>DIN1</i>	<i>NH1UD69V315PV</i>	<i>PC30UD69V315A</i>	<i>PC30UD69V315TF</i>	<i>690</i>	<i>315</i>	<i>6</i>
CH72	0385	385	DIN2	NH2UD69V700PV	PC31UD69V700A	PC31UD69V700TF	690	700	3
<i>CH72¹</i>	<i>0385</i>	<i>385</i>	<i>DIN1</i>	<i>NH1UD69V400PV</i>	<i>PC30UD69V400A</i>	<i>PC30UD69V400TF</i>	<i>690</i>	<i>400</i>	<i>6</i>
CH72	0416	416	DIN3	NH3UD69V800PV	PC32UD69V800A	PC32UD69V800TF	690	800	3
<i>CH72¹</i>	<i>0416</i>	<i>416</i>	<i>DIN1</i>	<i>NH1UD69V400PV</i>	<i>PC30UD69V400A</i>	<i>PC30UD69V400TF</i>	<i>690</i>	<i>400</i>	<i>6</i>
CH72	0460	460	DIN3	NH3UD69V1000PV	PC33UD69V1000A	PC33UD69V1000TF	690	1000	3
<i>CH72¹</i>	<i>0460</i>	<i>460</i>	<i>DIN1</i>	<i>NH1UD69V400PV</i>	<i>PC30UD69V400A</i>	<i>PC30UD69V400TF</i>	<i>690</i>	<i>400</i>	<i>6</i>
CH72	0502	502	DIN3	NH3UD69V1000PV	PC33UD69V1000A	PC33UD69V1000TF	690	1000	3
<i>CH72¹</i>	<i>0502</i>	<i>502</i>	<i>DIN2</i>	<i>NH2UD69V500PV</i>	<i>PC31UD69V500A</i>	<i>PC31UD69V500TF</i>	<i>690</i>	<i>500</i>	<i>6</i>
CH63	0590	590	DIN3	PC73UB69V1100PA	PC33UD69V1100A	PC33UD69V1100TF	690	1100	3
CH63	0650	650	DIN3	PC73UB69V1250PA	PC33UD69V1250A	PC33UD69V1250TF	690	1250	3
CH63	0750	750	DIN3	PC73UB69V1250PA	PC33UD69V1250A	PC33UD69V1250TF	690	1250	3
CH74	0820	820	DIN2	NH2UD69V500PV	PC31UD69V500A	PC31UD69V500TF	690	500	9
<i>CH74¹</i>	<i>0820</i>	<i>820</i>	<i>DIN3</i>	<i>NH3UD69V800PV</i>	<i>PC32UD69V800A</i>	<i>PC32UD69V800TF</i>	<i>690</i>	<i>800</i>	<i>6</i>
CH74	0920	920	DIN2	NH2UD69V700PV	PC31UD69V700A	PC31UD69V700TF	690	700	9
<i>CH74¹</i>	<i>0920</i>	<i>920</i>	<i>DIN3</i>	<i>NH3UD69V800PV</i>	<i>PC32UD69V800A</i>	<i>PC32UD69V800TF</i>	<i>690</i>	<i>800</i>	<i>6</i>
CH74	1030	1030	DIN2	NH2UD69V700PV	PC31UD69V700A	PC31UD69V700TF	690	700	9
<i>CH74¹</i>	<i>1030</i>	<i>1030</i>	<i>DIN3</i>	<i>NH3UD69V1000PV</i>	<i>PC33UD69V1000A</i>	<i>PC33UD69V1000TF</i>	<i>690</i>	<i>1000</i>	<i>6</i>
CH74	1180	1180	DIN3	NH3UD69V800PV	PC32UD69V800A	PC32UD69V800TF	690	800	9
<i>CH74¹</i>	<i>1180</i>	<i>1180</i>	<i>DIN3</i>	<i>PC73UB69V1100PA</i>	<i>PC33UD69V1100A</i>	<i>PC33UD69V1100TF</i>	<i>690</i>	<i>1100</i>	<i>6</i>
CH74	1300	1300	DIN3	NH3UD69V800PV	PC32UD69V800A	PC32UD69V800TF	690	800	9
<i>CH74¹</i>	<i>1300</i>	<i>1300</i>	<i>DIN3</i>	<i>PC73UB69V1250PA</i>	<i>PC33UD69V1250A</i>	<i>PC33UD69V1250TF</i>	<i>690</i>	<i>1250</i>	<i>6</i>
CH74	1500	1500	DIN3	NH3UD69V1000PV	PC33UD69V1000A	PC33UD69V1000TF	690	1000	9
<i>CH74¹</i>	<i>1500</i>	<i>1500</i>	<i>DIN3</i>	<i>PC73UB69V1250PA</i>	<i>PC33UD69V1250A</i>	<i>PC33UD69V1250TF</i>	<i>690</i>	<i>1250</i>	<i>6</i>
CH74	1700	1700	DIN3	NH3UD69V1000PV	PC33UD69V1000A	PC33UD69V1000TF	690	1000	9
<i>CH74¹</i>	<i>1700</i>	<i>1700</i>	<i>DIN3</i>	<i>NH3UD69V800PV</i>	<i>PC32UD69V800A</i>	<i>PC32UD69V800TF</i>	<i>690</i>	<i>800</i>	<i>12</i>

¹ Data in *Italic* refer to drives with 12-pulse supply

Fuse information

The values in tables are based on max ambient temperature of +50 °C.

Fuse sizes can differ in the same chassis. Make sure that the I_{sc} of the supply transformer is high enough to burn fuses fast enough.

Check the current rating of the fuse bases according to the input current of the drive.

The physical size of the fuse is chosen on the basis of the fuse current: Current > 400 amps (size 2 fuse or smaller), current < 400 amps (size 3 fuse). The aR fuses are thermally rated into switch fuse in 50 degrees ambient temperature.

6.1.3.2 Fuse sizes, inverters

Each DC supply line must be equipped with an aR fuse according to the tables below.

Table 43. Fuse sizes for VACON® NX Liquid-Cooled (450–800 V) inverters

Chassis	Type	I _{th} [A]	DIN43620			"TTF" threaded end "7X" or size 83 with end contacts		"TTQF" threaded end size 84 or "PLAF" 2x84 with end contacts		Fuse I _n [A]
			Fuse size	aR fuse part nr.	Fuses needed per drive	aR fuse part nr.	Fuses needed per drive	aR fuse part nr.	Fuses needed per drive	
CH3	0016	16	DIN0	PC70UD13C50PA	2	PC70UD13C50TF	2	-	-	50
CH3	0022	22	DIN0	PC70UD13C50PA	2	PC70UD13C50TF	2	-	-	50
CH3	0031	31	DIN0	PC70UD13C80PA	2	PC70UD13C63TF	2	-	-	80/63
CH3	0038	38	DIN0	PC70UD13C80PA	2	PC70UD13C80TF	2	-	-	125
CH3	0045	45	DIN0	PC70UD13C125PA	2	PC70UD13C125TF	2	-	-	125
CH3	0061	61	DIN0	PC70UD13C125PA	2	PC70UD13C125TF	2	-	-	125
CH4	72	72	DIN0	PC70UD13C200PA	2	PC70UD13C200TF	2	-	-	200
CH4	0087	87	DIN0	PC70UD13C200PA	2	PC70UD13C200TF	2	-	-	200
CH4	0105	105	DIN0	PC70UD13C200PA	2	PC70UD13C200TF	2	-	-	200
CH4	0140	140	DIN1	PC71UD13C315PA	2	PC71UD13C315TF	2	-	-	315
CH5	0168	168	DIN1	PC71UD13C315PA	2	PC71UD13C315TF	2	-	-	315
CH5	0205	205	DIN1	PC71UD13C400PA	2	PC71UD13C400TF	2	-	-	400
CH5	0261	261	DIN3	PC73UD13C500PA	2	PC73UD13C500TF	2	-	-	500
CH61	0300	300	DIN3	PC73UD13C630PA	2	PC73UD13C630TF	2	-	-	630
CH61	0385	385	DIN3	PC73UD11C800PA	2	PC73UD13C800TF	2	-	-	800
CH62	460	460	DIN3	PC73UD90V11CPA	2	PC73UD95V11CTF	2	-	-	1100
CH62	520	520	DIN3	PC73UD90V11CPA	2	PC73UD95V11CTF	2	-	-	1100
CH62	590	590	DIN3	PC73UD13C630PA	4	PC73UD95V11CTF	2	-	-	630/1100
CH62	650	650	DIN3	PC73UD13C630PA	4	PC83UD11C13CTF	2	-	-	630/1300
CH62	730	730	DIN3	PC73UD11C800PA	4	PC83UD11C13CTF	2	-	-	800/1300
CH63	0820	820	DIN3	PC73UD11C800PA	4	PC73UD13C800TF	4	PC84UD13C15CTQ	2	800/1500
CH63	0920	920	DIN3	PC73UD90V11CPA	4	PC73UD95V11CTF	4	PC84UD12C18CTQ	2	1100/1800
CH63	1030	1030	DIN3	PC73UD90V11CPA	4	PC73UD13C800TF	4	PC84UD11C20CTQ	2	1100/800/2000
CH63	1150	1150	-	-	-	PC83UD11C13CTF	4	PC84UD11C22CTQ	2	1300/2200
CH64	1370	1370	-	-	-	PC83UD11C14CTF	4	PC84UD10C27CTQ	2	1400/2700

Table 43. Fuse sizes for VACON® NX Liquid-Cooled (450–800 V) inverters

Chassis	Type	I _{th} [A]	DIN43620			"TTF" threaded end "7X" or size 83 with end contacts	"TTQF" threaded end size84 or "PLAF" 2x84 with end contacts		Fuse I _n [A]	
			Fuse size	aR fuse part nr.	Fuses needed per drive	aR fuse part nr.	Fuses needed per drive	aR fuse part nr.		Fuses needed per drive
CH64	1640	1640	-	-	-	PC73UD13C800TF	8	PC87UD12C30CP50	2	800/3000
CH64	2060	2060	-	-	-	PC73UD95V11CTF	8	PC87UD11C38CP50	2	1100/3800
CH64	2300	2300	-	-	-	PC73UD95V11CTF	8	PC87UD10C44CP50	2	1100/4400

Table 44. Fuse sizes for VACON® NX Liquid-Cooled (640–1100 V) inverters

Chassis	Type	I _{th} [A]	DIN43620			"TTF" threaded end "7X" or size 83 with end contacts	"TTQF" threaded end size84 or "PLAF" 2x84 with end contacts		Fuse I _n [A]	
			Fuse size	aR fuse part nr.	Fuses needed per drive	aR fuse part nr.	Fuses needed per drive	aR fuse part nr.		Fuses needed per drive
CH61	0170	170	DIN1	PC71UD13C400PA	2	PC71UD13C400TF	2	-	-	400
CH61	0208	208	DIN1	PC71UD13C400PA	2	PC71UD13C400TF	2	-	-	400
CH61	0261	261	DIN1	PC73UD13C500PA	2	PC73UD13C500TF	2	-	-	500
CH62	0325	325	DIN3	PC73UD13C630PA	2	PC73UD13C630TF	2	-	-	630
CH62	0385	385	DIN3	PC73UD11C800PA	2	PC73UD13C800TF	2	-	-	800
CH62	0416	416	DIN3	PC73UD11C800PA	2	PC73UD13C800TF	2	-	-	800
CH62	0460	460	DIN3	PC73UD10C900PA	2	PC73UD12C900TF	2	-	-	900
CH62	0502	502	DIN3	PC73UD10C900PA	2	PC73UD12C900TF	2	-	-	900
CH63	0590	590	DIN3	PC73UD13C630PA	4	PC83UD12C11CTF	2	-	-	630/1100
CH63	0650	650	DIN3	PC73UD13C630PA	4	PC83UD11C13CTF	2	-	-	630/1300
CH63	0750	750	DIN3	PC73UD11C800PA	4	PC83UD11C14CTF	2	-	-	800/1400
CH64	0820	820	DIN3	PC73UD11C800PA	4	PC73UD13C800TF	4	PC84UD13C15CTQ	2	800/1500
CH64	0920	920	DIN3	PC73UD10C900PA	4	PC73UD12C900TF	4	PC84UD12C18CTQ	2	900/1800
CH64	1030	1030	-	-	-	PC83UD12C11CTF	4	PC84UD11C20CTQ	2	1100/2000

Table 44. Fuse sizes for VACON® NX Liquid-Cooled (640–1100 V) inverters

Chassis	Type	I _{th} [A]	DIN43620			"TTF" threaded end "7X" or size 83 with end contacts		"TTQF" threaded end size84 or "PLAF" 2x84 with end contacts		Fuse I _n [A]
			Fuse size	aR fuse part nr.	Fuses needed per drive	aR fuse part nr.	Fuses needed per drive	aR fuse part nr.	Fuses needed per drive	
CH64	1180	1180	-	-	-	PC83UD12C11CTF	4	PC84UD11C22CTQ	2	1100/2200
CH64	1300	1300	-	-	-	PC83UD11C13CTF	4	PC84UD11C24CTQ	2	1300/2400
CH64	1500	1500	-	-	-	PC83UD11C14CTF	4	PC87UD12C30CP50	2	1400/3000
CH64	1700	1700	-	-	-	PC73UD12C900TF	8	PC87UD11C34CP50	2	900/3400
CH64	1900	1900	-	-	-	PC73UD12C900TF	8	PC87UD11C34CP50	2	900/3400

Fuse information

The values in tables are based on max ambient temperature of +50 °C.

Fuse sizes can differ in the same chassis. Fuses can be chosen according to the biggest current rating of the chassis to minimize fuse variants. Make sure that the I_{sc} of the supply transformer is high enough to burn fuses fast enough.

Check the current rating of the fuse bases according to the input current of the drive.

The physical size of the fuse is chosen on the basis of the fuse current: Current < 250 amps (size 1 fuse), current > 250 amps (size 3 fuse).

The aR fuses are thermally rated into switch fuse in 50 degree ambient temperature.

6.1.4 CABLE INSTALLATION INSTRUCTIONS

1	Before starting the installation, check that none of the components of the AC drive is live.
2	VACON® NX Liquid-Cooled drive must always be installed in an enclosure, a separate cubicle or an electrical room. Always use a jib crane or similar lifting device to lift the drive. For safe and appropriate lifting, see Chapter 5.1.1.

3	<p>Place the motor cables far enough from other cables:</p> <ul style="list-style-type: none"> • Avoid placing the motor cables in long parallel lines with other cables • If the motor cables run in parallel with other cables, note the minimum distances between the motor cables and other cables given in table below. • The given distances also apply between the motor cables and signal cables of other systems. <table border="1" style="margin-left: auto; margin-right: auto;"> <thead> <tr> <th style="background-color: black; color: white;">Distance between parallelly running cables [m]</th> <th style="background-color: black; color: white;">Shielded cable [m]</th> </tr> </thead> <tbody> <tr> <td style="text-align: center;">0.3</td> <td style="text-align: center;">≤ 50</td> </tr> <tr> <td style="text-align: center;">1.0</td> <td style="text-align: center;">≤ 200</td> </tr> </tbody> </table> <ul style="list-style-type: none"> • The maximum length of the motor cables is 300 m. • The motor cables should cross other cables at an angle of 90 degrees. 	Distance between parallelly running cables [m]	Shielded cable [m]	0.3	≤ 50	1.0	≤ 200
Distance between parallelly running cables [m]	Shielded cable [m]						
0.3	≤ 50						
1.0	≤ 200						
4	If cable insulation checks are needed, see Chapter 6.1.10.						
5	<p>Connect the cables/busbars:</p> <ul style="list-style-type: none"> • For chassis CH5 and greater, an external flexible cable connection block must be used at both mains and motor ends if stiff cable type (EMCMK, MCMK) is used. See Chapter 6.1.1. • Strip the cables at a sufficient distance if needed. • Connect the mains, motor and control cables to their respective terminals (see Chapter 5.1.2). If busbar connection is used, bolt the bars and the terminals together. See bolt sizes on page 33 to page 44. • Take the maximum terminal stresses shown in Figure 37 into account. • For information on cable installation according to UL regulations see Chapter 6.1.9. • Make sure that the control cable wires do not come in contact with the electronic components of the unit. • If an external brake resistor (option) is used, connect its cable to the appropriate terminal. • Check the connection of the earth cable to the motor and the AC drive terminals marked with . • Connect the separate shield of the power cable to the earth terminals of the AC drive, motor and the supply centre. 						
6	Clamp the motor cables to the cabinet frame as instructed in Figure 36.						
7	<p>Liquid cooling connection:</p> <p>The standard delivery of the VACON® NX Liquid-Cooled drive includes hoses on the cooling element 1.5 m in length and 15 mm in diameter. The hoses are inserted in 1400-mm UL94V0 approved conduits. Connect the line hose branch to its counterpart (screw or fast connector) on the of the VACON® Liquid-Cooled drive.</p> <p>Due to high pressure in the line hose, it is recommended to equip the liquid line with a shut-off valve, which makes the connection easier. In order to prevent water from spraying in the installation room we also recommend to wrap e.g. lintners around the connection on installing. For more information on the liquid connection, see Chapter 5.2.2.</p> <p>When the installation in the enclosure is completed the liquid pump can be started. See Commissioning of the AC drive on page 137.</p> <p>NOTE! Do not switch on the power before ensuring the proper functioning of the liquid cooling system.</p>						

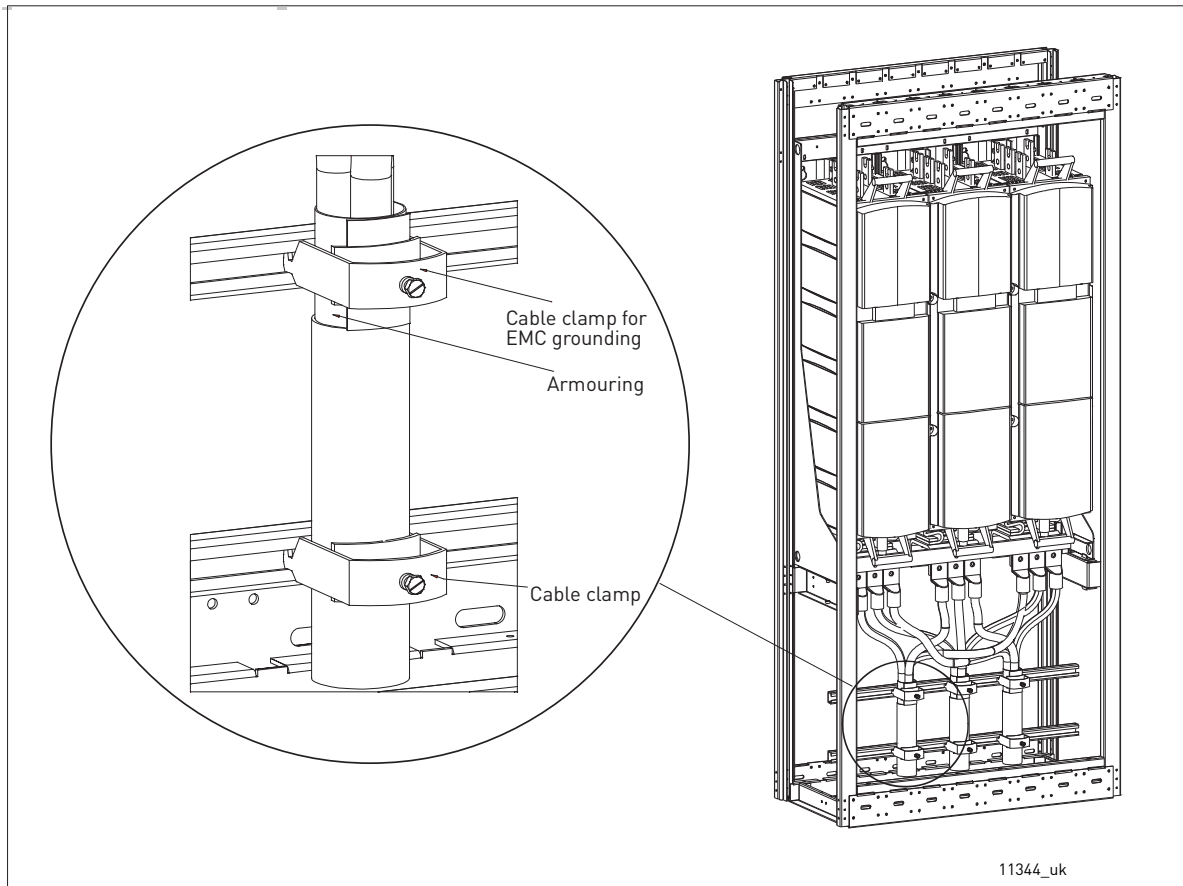

Figure 36. Clamping the motor cables to cabinet frame

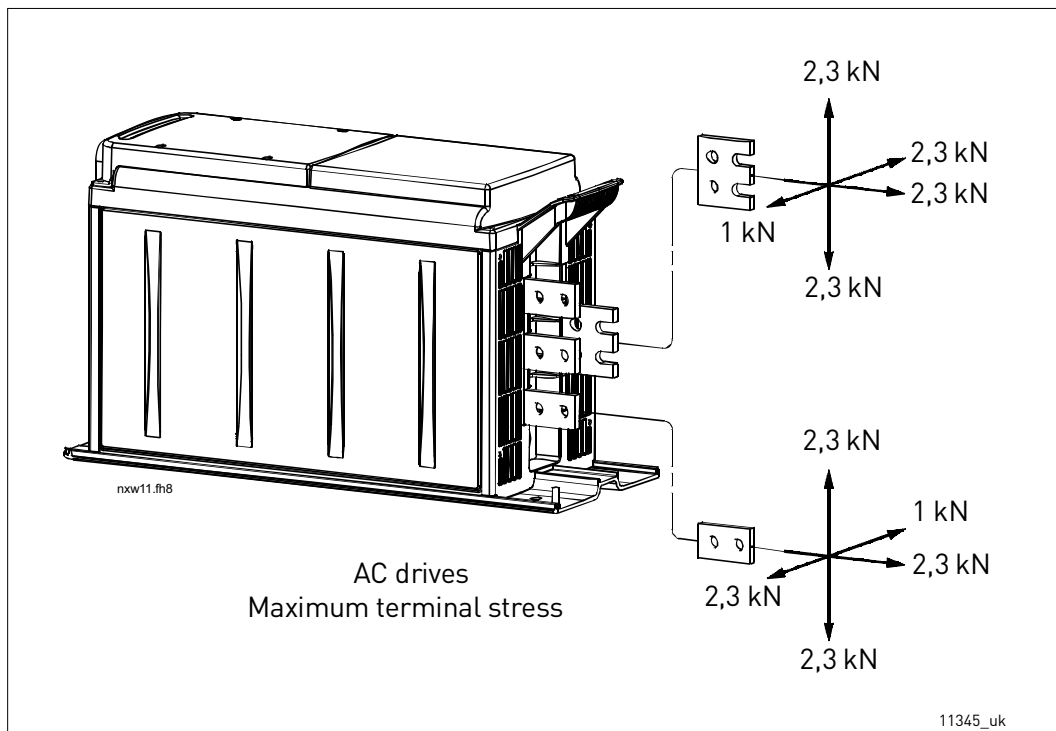

Figure 37. Maximum terminal stresses

6.1.5 SUPPLY BUSBARS FOR INVERTER UNITS

In order to avoid excessive terminal stresses on busbar terminals on inverter units with DC-supply on top (CH61...CH64), use flexible busbar connection. See figure below. The maximum terminal stresses are shown in Figure 37.

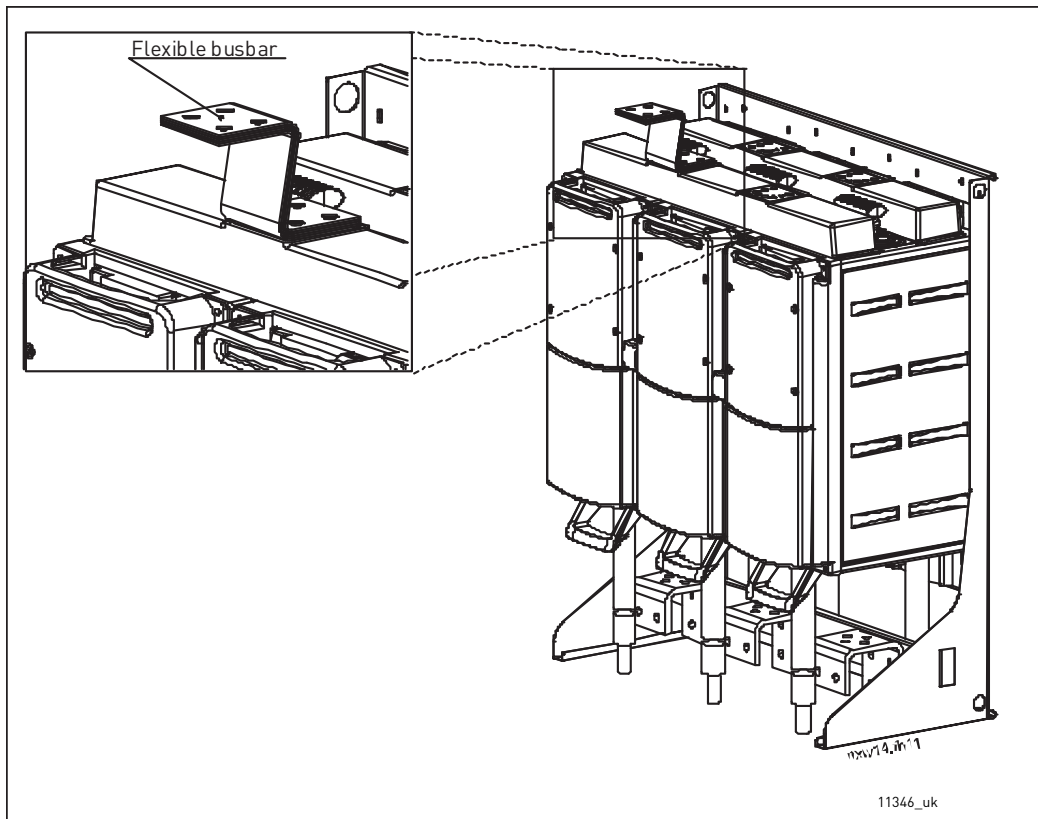

Figure 38. Mounting of flexible busbar

6.1.6 INSTALLATION SPACE

Enough free space must be left above and below the AC drive/inverter to ensure practical and appropriate electrical and cooling connections. The minimum dimensions are given in the table below. The space left and right to the drive may be 0 mm.

Table 45. Installation space

Chassis	A [mm]	B [mm]
CH3	100	150
CH4	100	200
CH5	100	200
CH61	100	300
CH62	100	400*
CH63	200	400*
CH64	200	500*
CH72	200	400*
CH74	200	500*

*Distance to the cable connection block. Additional space must be reserved for possibly used ferrite rings. See Chapter 6.1.1.2.

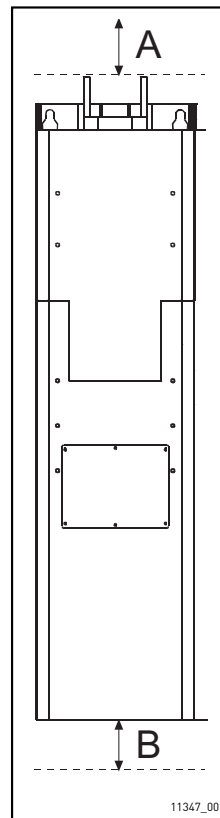

6.1.7 GROUNDING OF POWER UNIT

The mains cables are connected to the protective earth of the switchgear enclosure.

We recommend to connect the motor cables to the common PE of the cabinet/cabinet system.

For grounding of the drive itself, use the grounding terminal on the drive mounting plate (see Figure 39) and tighten the grounding bolt to 13.5 Nm.

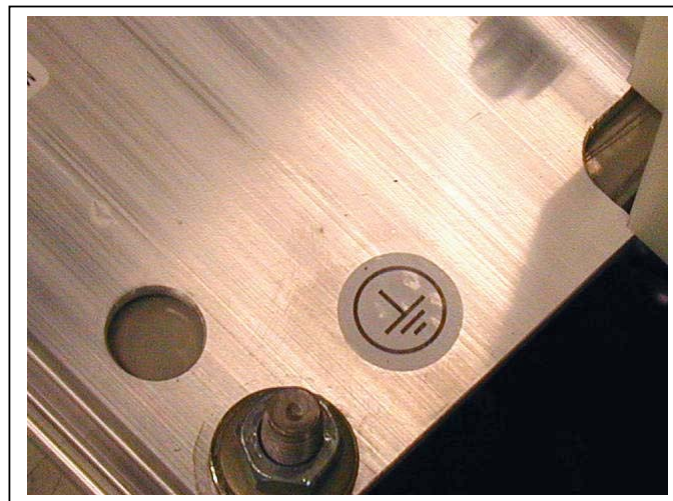

11348 00

Figure 39. Grounding terminal on mounting plate

6.1.8 INSTALLATION OF FERRITE RINGS (OPTION) ON THE MOTOR CABLE

Slip only the phase conductors through the window; leave the cable screen below and outside the rings, see Figure 40. Separate the PE conductor. In case of parallel motor cables, reserve an equal amount of ferrite rings for each cable and feed all the phase conductors of one cable through one set of rings. The delivery includes fixed sets of ferrite rings.

When ferrite rings are used to attenuate the risk of bearing damages, the number of ferrites has to be 6...10 for a single motor cable and 10 per cable when the motor is supplied with parallel cables.

NOTE! The ferrite rings are only additional protection. The basic protection against bearing currents is an insulated bearing.

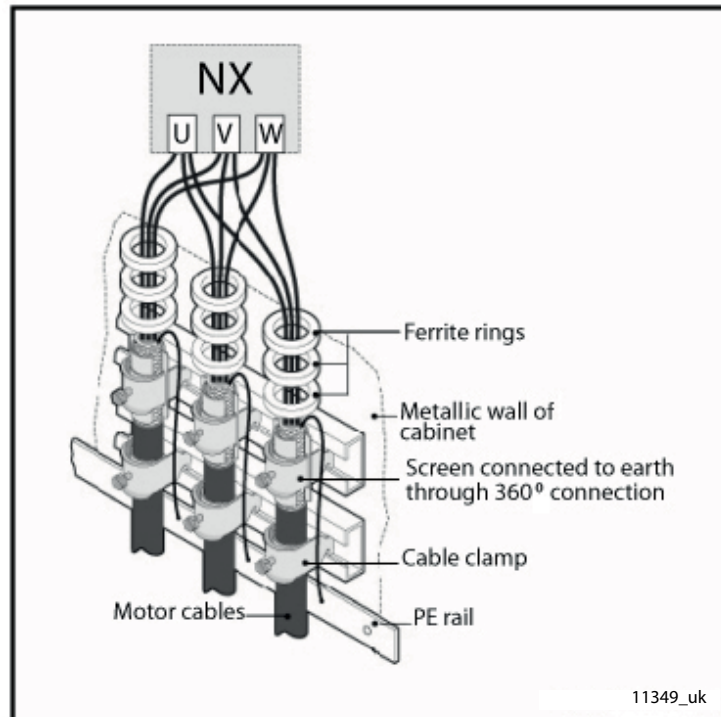

Figure 40.

Installation of ferrite rings

6.1.9 CABLE INSTALLATION AND THE UL STANDARDS

To meet the UL (Underwriters Laboratories) regulations, a UL-approved copper cable with a minimum heat-resistance of 90 °C must be used.

Use Class 1 wire only.

The units are suitable for use on a circuit capable of delivering not more than 100,000 rms symmetrical amperes, 600 V maximum.

The tightening torques of the terminals are given in Table 40.

6.1.10 CABLE AND MOTOR INSULATION CHECKS

Motor cable insulation checks

1. Disconnect the motor cable from terminals U, V and W of the AC drive and from the motor. Measure the insulation resistance of the motor cable between each phase conductor as well as between each phase conductor and the protective ground conductor.

Mains cable insulation checks

2. Disconnect the mains cable from terminals L1, L2 and L3 of the AC drive and from the mains. Measure the insulation resistance of the mains cable between each phase conductor as well as between each phase conductor and the protective ground conductor.

The insulation resistance must be at least 1...2 M Ω .

Motor insulation checks

3. Disconnect the motor cable from the motor and open the bridging connections in the motor connection box. Measure the insulation resistance of each motor winding. The measurement voltage must equal at least the motor nominal voltage but not exceed 1000 V. The insulation resistance must be at least 1...2 M Ω .

6.2 CONTROL UNIT

The control unit of VACON® NX Liquid-Cooled AC drive/inverter is installed into a mounting box. It contains the control board and additional boards (see Figure 41 and Figure 42) connected to the five slot connectors (A to E) of the control board. The control unit and the ASIC of the power unit are connected through cables (and an adapter board). For more information, see page 108.

The mounting box with the control unit is mounted inside an enclosure. See the mounting instructions on page 103.

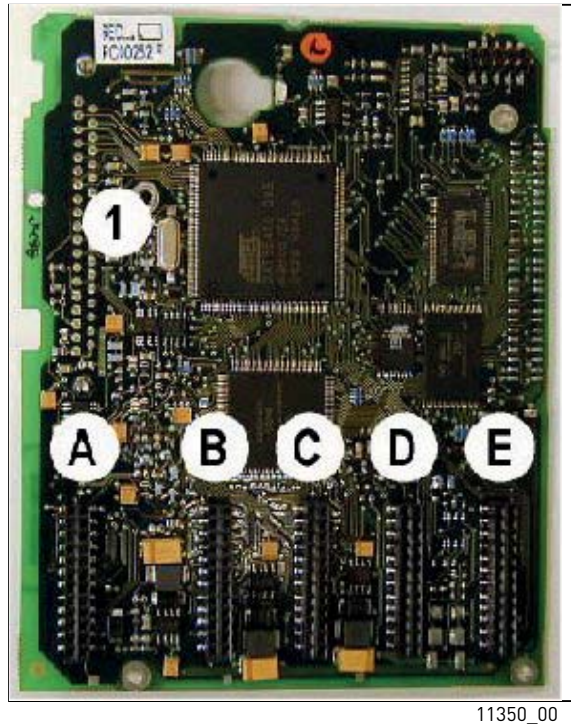

11350_00

Figure 41. VACON® NX control board

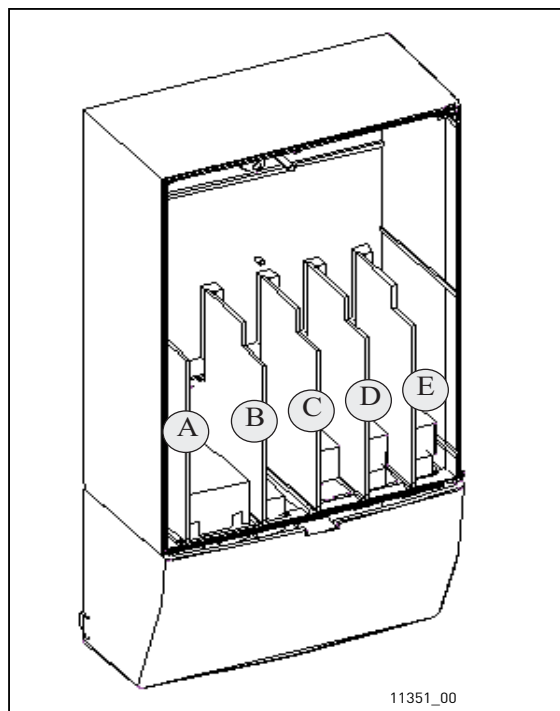

11351_00

Figure 42. Basic and option board connections on the control board

Usually, when the AC drive is delivered from the factory, the control unit includes at least the standard compilation of two basic boards (I/O board and relay board) which are normally installed in slots A and B. On the next pages you will find the arrangement of the control I/O and the relay terminals of the two basic boards, the general wiring diagram and the control signal descriptions. The I/O boards mounted at the factory are indicated in the type code.

The control board can be powered externally (+24 VDC, $\pm 10\%$) by connecting the external power source to the control unit. This voltage is sufficient for parameter setting and for keeping the fieldbus active.

NOTE! The control board of NX_8 (voltage class 8) AFE, INU or BCU units must always be powered externally with a +24 VDC $\pm 10\%$ power source.

The preferred solution is to connect the external +24 VDC power supply to the fiber adapter board terminals X3:1 (24 VDC) & X3:2 (GND) or star coupler board terminals X4:25 (24VDC) & X4:26 (GND), see pictures below.

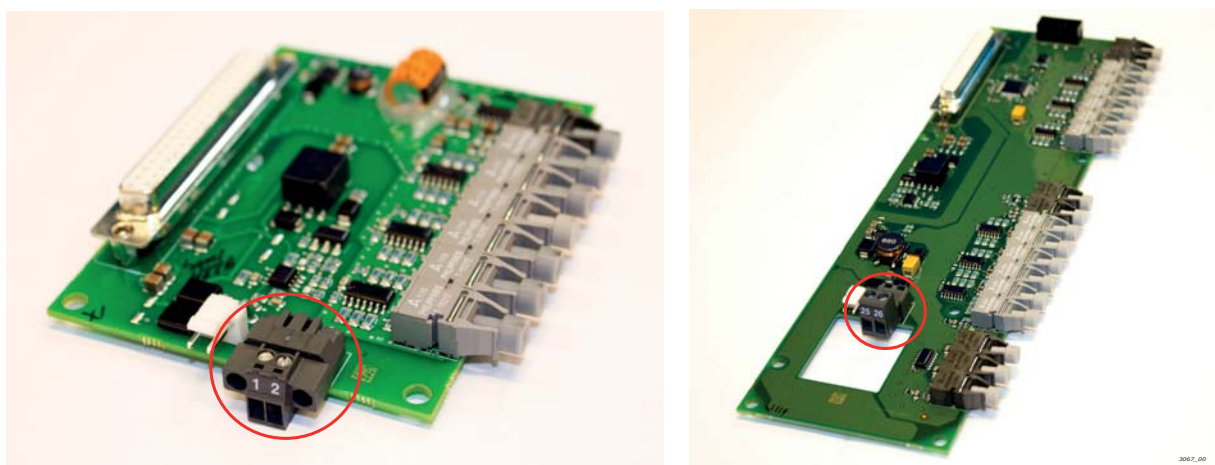

The control board can also be powered externally (+24 V, $\pm 10\%$) by connecting the external power source to either of the bidirectional terminal #6 or #12, see page 98.

NOTE! If the 24 V inputs of several AC drives are parallelly connected we recommend to use a diode in terminal #6 (or #12) in order to avoid the current to flow in opposite direction. This might damage the control board. See picture below.

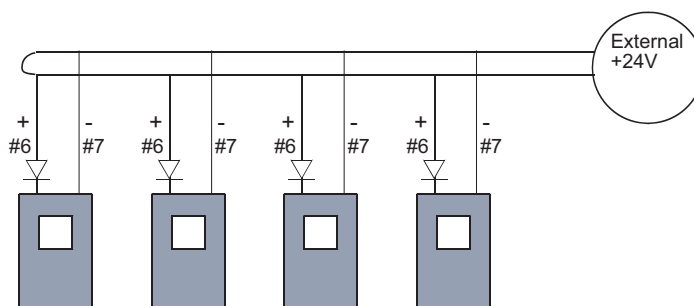

11352_uk

6.2.1 CONTROL BOARD POWER-UP

The control board can be powered (+24 V) in two different ways: either 1) directly from the power board ASIC, terminal X10 or/and 2) externally using the customer’s own power source. The two ways of supplying the board can be used simultaneously. This voltage is sufficient for parameter setting and for keeping the fieldbus active.

By factory default, the control unit is powered using the terminal X10 on the power board. However, if an external supply is used to power up the control unit, a load resistor must be connected to terminal X10 on the power board. This applies to all chassis ≥ CH61.

6.2.2 CONTROL CONNECTIONS

The basic control connections for boards A1 and A2 are shown in Chapter 6.2.3.

The signal descriptions are presented in VACON® NX All in One Application Manual.

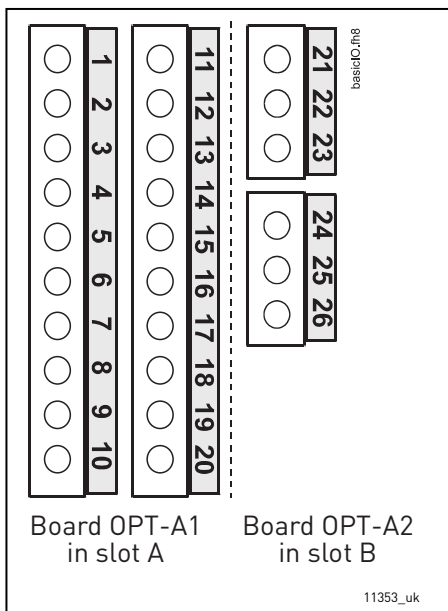

Figure 43. The I/O terminals of the two basic boards

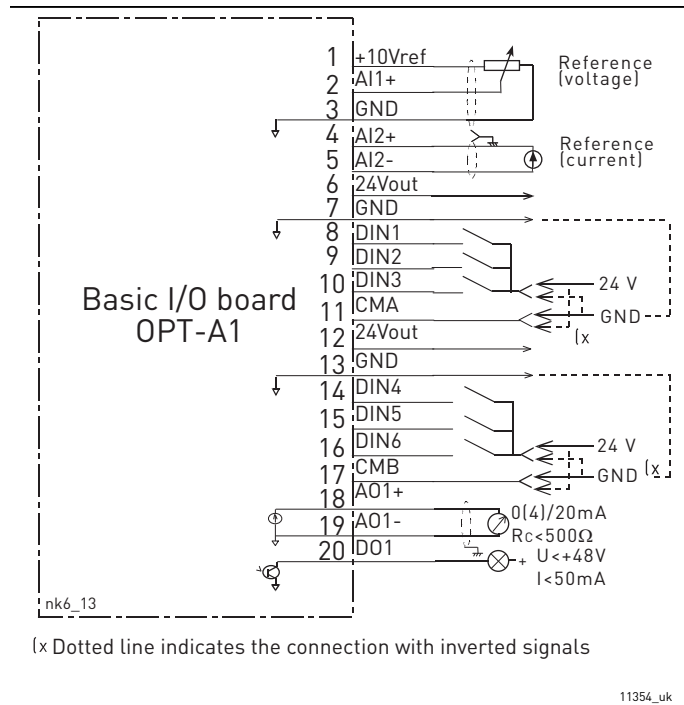

Figure 44. General wiring diagram of the basic I/O board (OPT-A1)

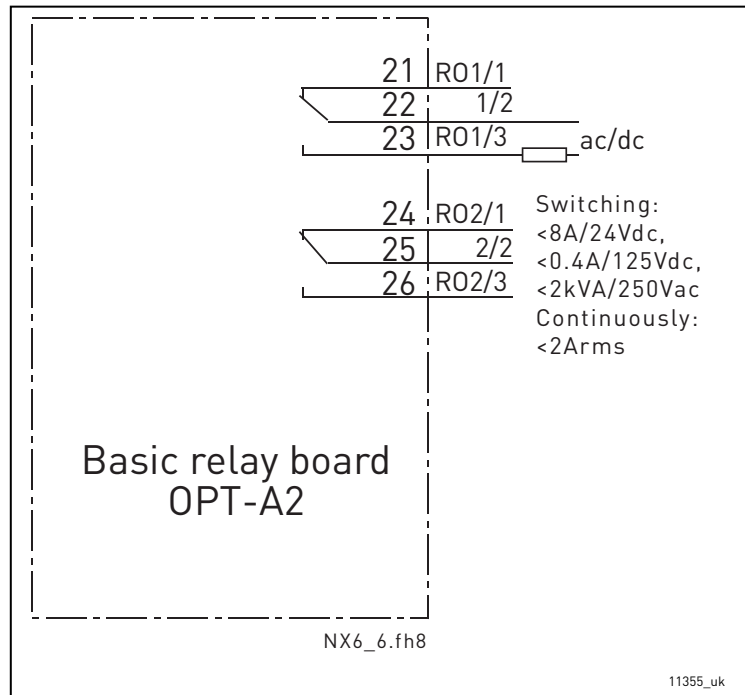

Figure 45. General wiring diagram of the basic relay board (OPT-A2)

6.2.2.1 Control cables

The control cables must be at least 0.5 mm^2 screened multicore cables, see Table 35. The maximum terminal wire size is 2.5 mm^2 for the relay terminals and 1.5 mm^2 for other terminals.

6.2.2.2 Galvanic isolation barriers

The control connections are isolated from the mains potential and the GND terminals are permanently connected to ground. See Figure 46.

The digital inputs are galvanically isolated from the I/O ground. The relay outputs are additionally double-isolated from each other at 300 VAC (EN-50178).

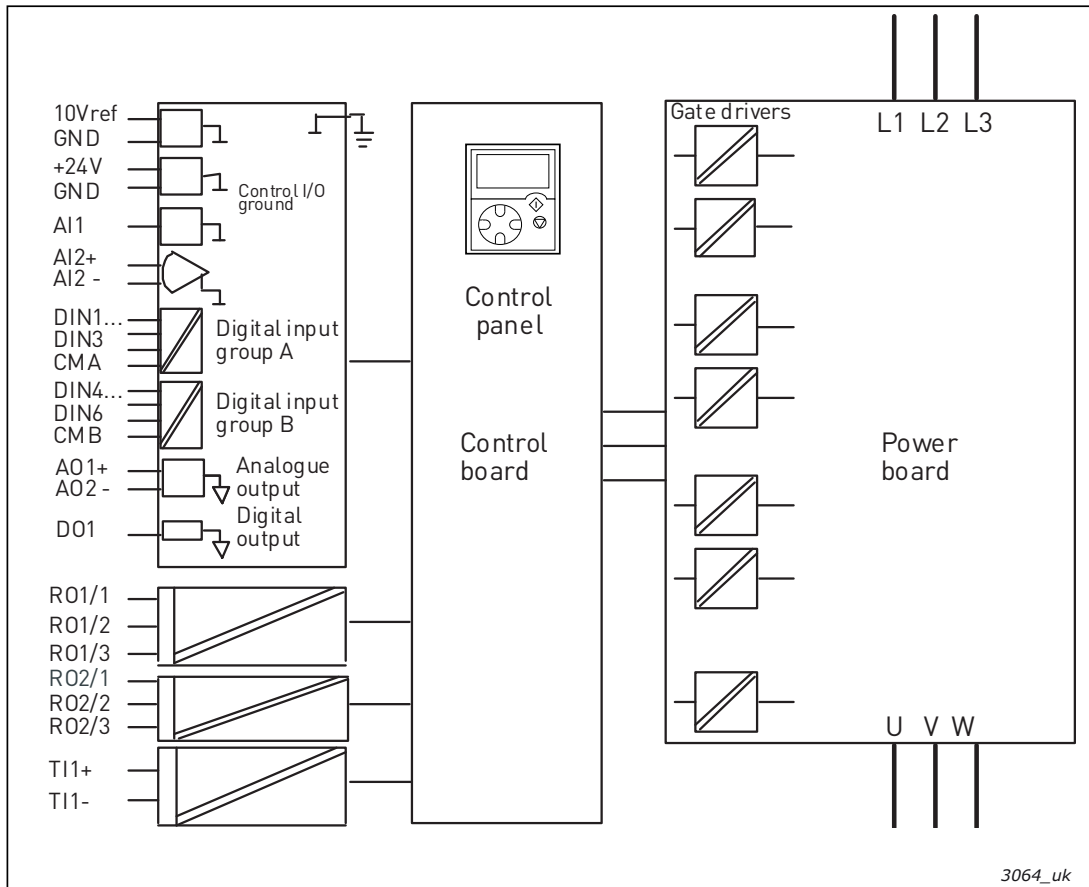

Figure 46. Galvanic isolation barriers

6.2.3 CONTROL TERMINAL SIGNALS

Table 46. Control I/O terminal signals

Terminal	Signal	Technical information
OPT-A1		
1	+10 Vref	Reference voltage Maximum current 10 mA
2	AI1+	Analogue input, voltage or current Selection V or mA with jumper block X1 (see page 102): Default: 0– +10 V (Ri = 200 kΩ) (–10 V.....+10 V Joy-stick control, selected with a jumper) 0– 20 mA (Ri = 250 Ω)
3	GND/AI1–	Analogue input common Differential input if not connected to ground; Allows ±20 V differential mode voltage to GND
4	AI2+	Analogue input, voltage or current Selection V or mA with jumper block X2 (see page 102): Default: 0– 20 mA (Ri = 250 Ω) 0– +10 V (Ri = 200 kΩ) (–10 V.....+10 V Joy-stick control, selected with a jumper)

Table 46. Control I/O terminal signals

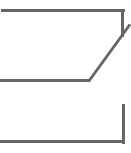
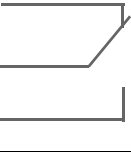
Terminal		Signal	Technical information	
5	GND/AI2-	Analogue input common	Differential input if not connected to ground; Allows ± 20 V differential mode voltage to GND	
6	24 V _{out} (bidirectional)	24 V auxiliary voltage	$\pm 15\%$, maximum current 250 mA Can also be used as external power backup for the control unit (and fieldbus)	
7	GND	I/O ground	Ground for reference and controls	
8	DIN1	Digital input 1	$R_i = \text{min. } 5 \text{ k}\Omega$ 18...30 V = "1"	
9	DIN2	Digital input 2		
10	DIN3	Digital input 3		
11	CMA	Digital input common A for DIN1, DIN2 and DIN3.	Must be connected to GND or 24 V of I/O terminal or to external 24 V or GND Selection with jumper block X3 (see page 102):	
12	24 V _{out} (bidirectional)	24 V auxiliary voltage	Same as terminal #6	
13	GND	I/O ground	Same as terminal #7	
14	DIB4	Digital input 4	$R_i = \text{min. } 5 \text{ k}\Omega$	
15	DIB5	Digital input 5		
16	DIB6	Digital input 6		
17	CMB	Digital input common B for DIB4, DIB5 and DIB6	Must be connected to GND or 24V of I/O terminal or to external 24 V or GND Selection with jumper block X3 (see page 102):	
18	A01+	Analogue signal (+output)	Output signal range: Current 0(4)–20 mA, $R_L \text{ max } 500 \Omega$ or Voltage 0–10 V, $R_L > 1 \text{ k}\Omega$	
19	A01-	Analogue output common	Selection with jumper block X6 (see page 102):	
20	DO1	Open collector output	Maximum $U_{in} = 48 \text{ VDC}$ Maximum current = 50 mA	
OPT-A2				
21	R01/1	 Relay output 1	Max. switching voltage	250 VAC, 125 VDC
22	R01/2		Max. switching current	8 A/24 VDC, 0.4 A/250 VDC
23	R01/3		Min. switching load	5 V/10 mA
24	R02/1	 Relay output 2	Max. switching voltage	250 VAC, 125 VDC
25	R02/2		Max. switching current	8 A/24 VDC, 0.4 A/250 VDC
26	R02/3		Min. switching load	5 V/10 mA

6.2.3.1 Digital input signal inversions

The active signal level depends on which potential the common inputs CMA and CMB (terminals 11 and 17) are connected to. The alternatives are either +24 V or ground (0 V). See Figure 47.

The 24-volt control voltage and the ground for the digital inputs and the common inputs (CMA, CMB) can be either internal or external.

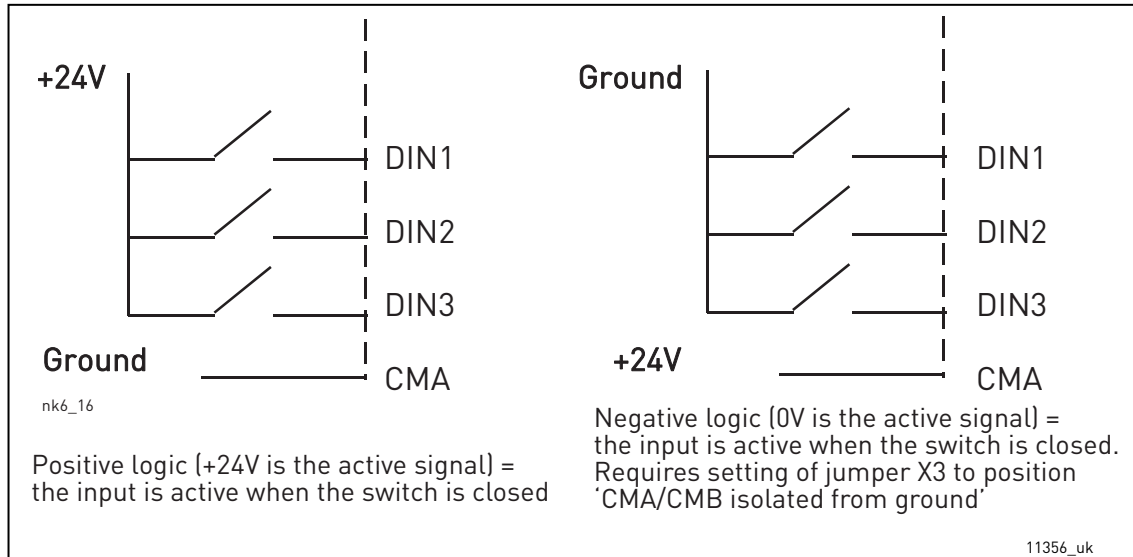
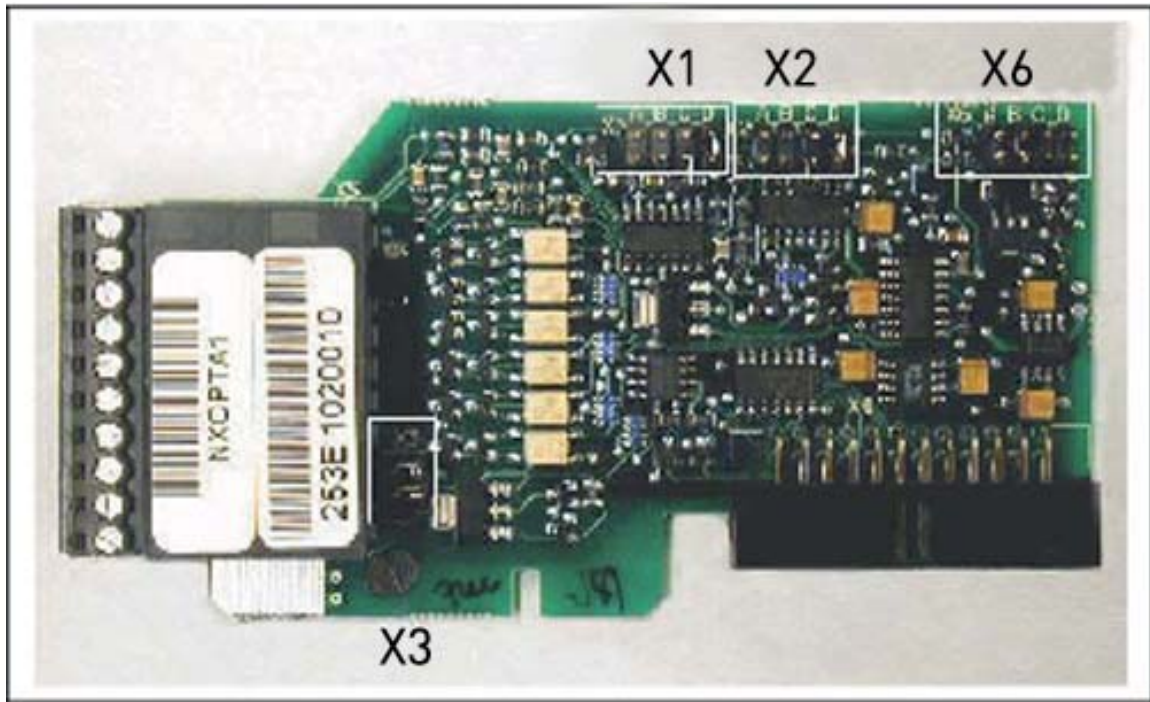

Figure 47. Positive/Negative logic

6.2.3.2 Jumper selections on the OPT-A1 basic board

The user is able to customise the functions of the AC drive to better suit his needs by selecting certain positions for the jumpers on the OPT-A1 board. The positions of the jumpers determine the signal type of analogue and digital inputs.

On the A1 basic board, there are four jumper blocks X1, X2, X3 and X6 each containing eight pins and two jumpers. The selectable positions of the jumpers are shown in Figure 49.



11357_00

Figure 48. Jumper blocks on OPT-A1

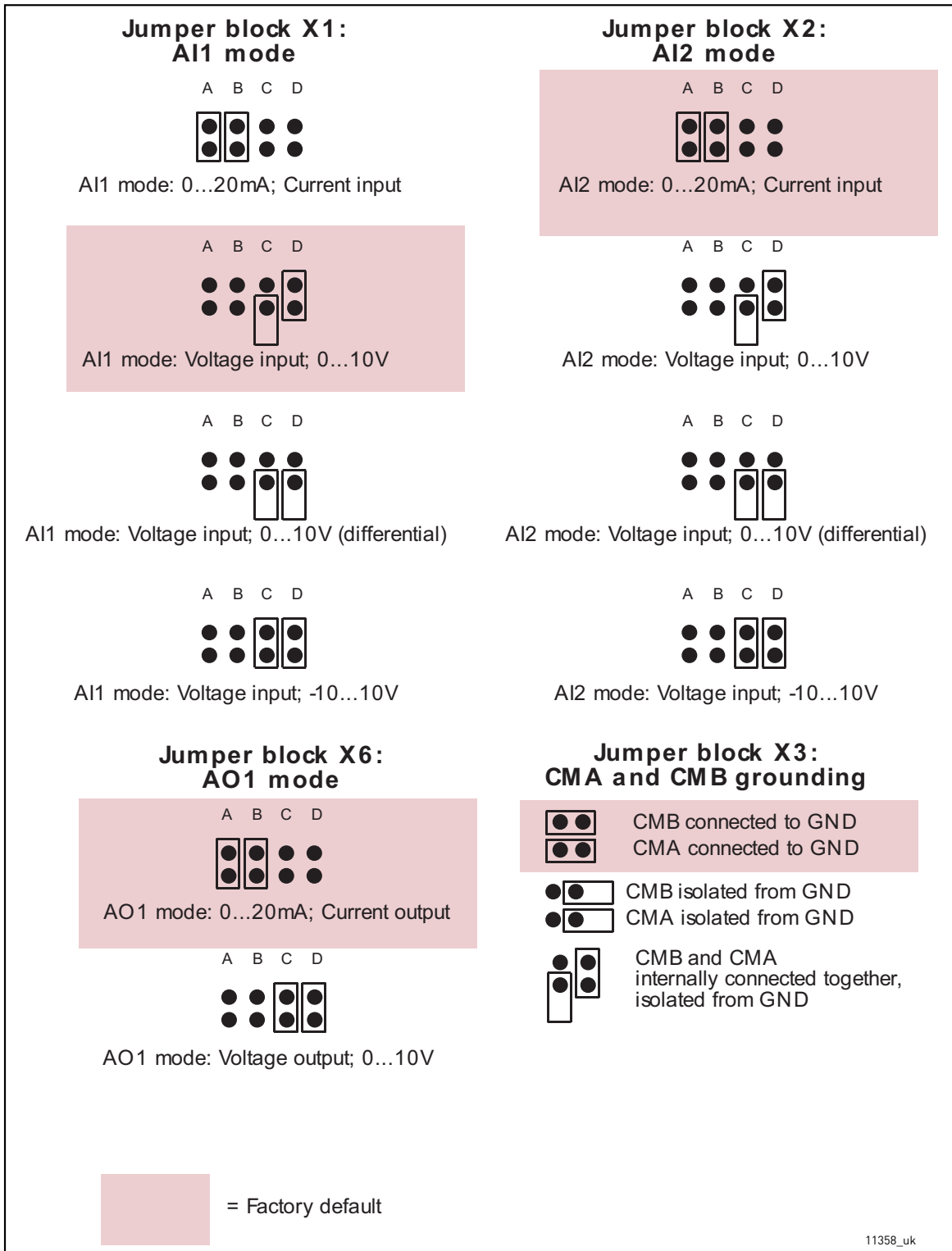

11358_uk

Figure 49. Jumper selection for OPT-A1

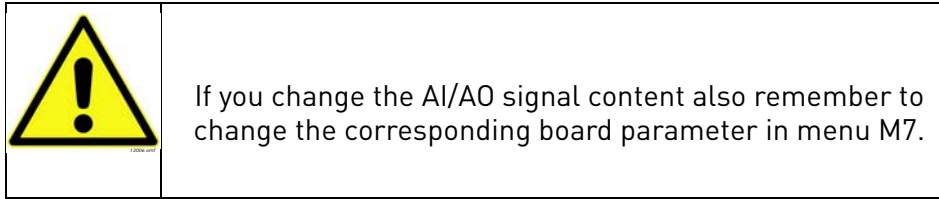

6.2.4 CONTROL UNIT MOUNTING BOX

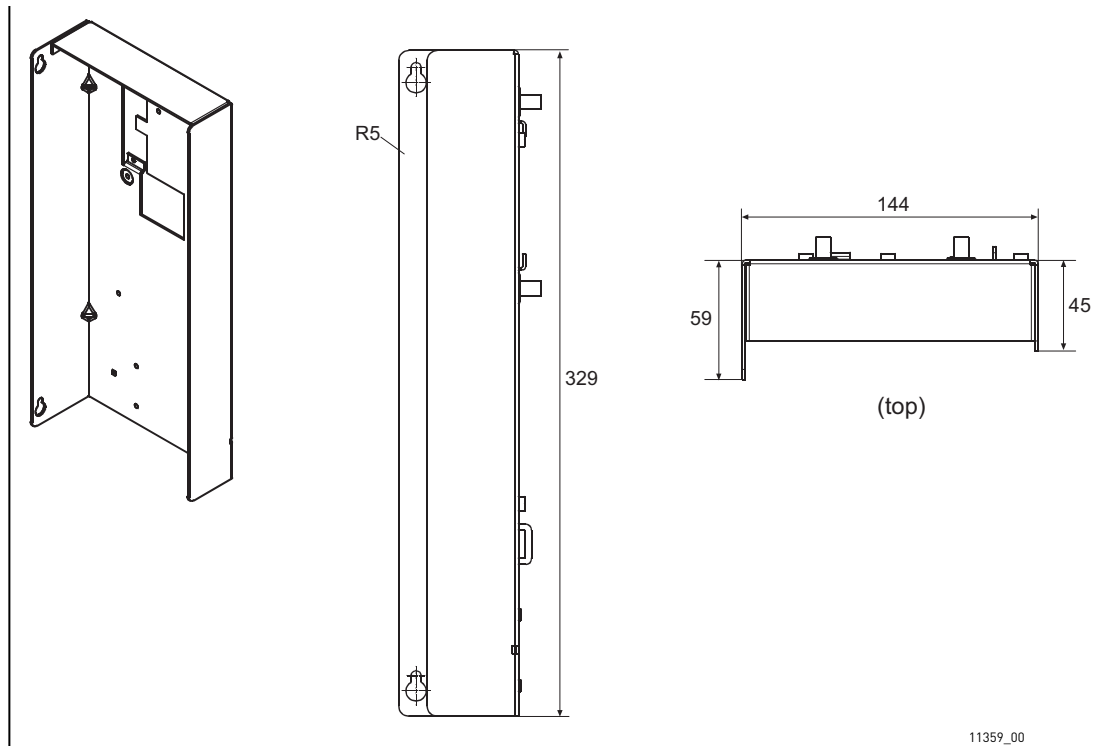
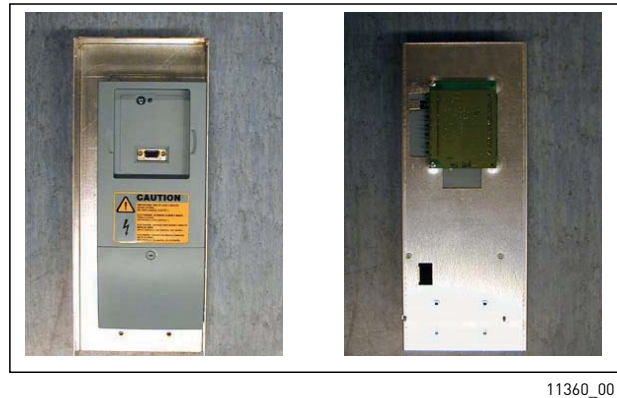

Figure 50. Control unit mounting box dimensions

6.2.4.1 Installing the control unit mounting box

The control unit of VACON[®] NX Liquid-Cooled drive is mounted into a metal box which then can be placed inside the enclosure. VACON[®] alpha-numeric or graphical keypad can be used to control the

drive. The keypad is connected to the control unit with an RS232 cable and mounted on the enclosure door. Pay special attention to the grounding of the cable, see instructions below.



11360_00

Figure 51. Control unit installed into the mounting box; Left: front; Right: back

1. If the keypad sits in its place on the control unit, remove the keypad.
2. Connect the male end of the keypad cable to the D-connector of the control unit. Use VACON® RS232 cable included in the delivery. Figure 1.
3. Run the cable over the top of the box and secure with plastic band on the backside. Figure 2.
4. Grounding of keypad cable: Earth the keypad cable in the mounting box frame by fixing the branch cable with a screw underneath the control unit. See Figures 3 and 4.

Mount the control unit mounting box in the front-left corner of the enclosure using two screws as shown in Figure 5. **NOTE!** Do not install the mounting box floating (with e.g. plastic screws). To ensure a proper grounding of the control unit box assembly, we recommend that

5. an additional grounding cable be drawn from the mounting box and connected to the cabinet frame. Use a braided copper cable designed for high-frequency signals. Remember to remove the paint from the enclosure grounding point to ensure proper connection for the grounding cable.
6. Connect the optical cables (or the flat cable) to the power unit. See Chapter 6.3.2 and Figures 6 and 7.
7. Connect the female end of the keypad cable to keypad on the enclosure door, Figure 8. Use a cable channel for the cable run, Figure 9.



11361_00

Figure. 1



11362_00

Figure. 2



11363_00

Figure. 3



11363_00

Figure. 4



11364_00

Figure. 5



11365_00

Figure. 6

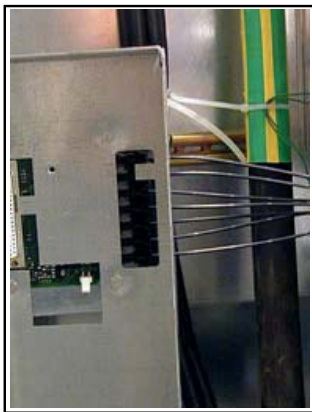

11366_00

Figure. 7



11367_00

Figure. 8

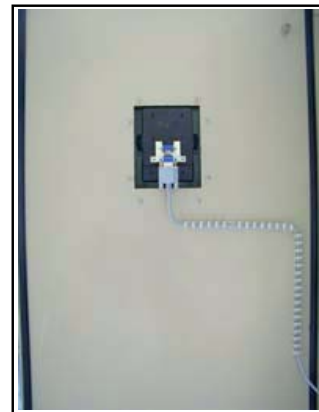

11368_00

Figure. 9

6.3 INTERNAL CONNECTIONS

As a general rule, all internal electrical and communications connections are made at the factory. However, if modules have to be moved, for example, and the connections therefore removed, you will have to re-establish the connections between 1) the Power Unit ASIC and the Driver Board(s) on the one hand and 2) the Power Unit ASIC and the Optical Cable Adapter Board on the other.

6.3.1 CONNECTIONS BETWEEN POWER UNIT ASIC AND DRIVER BOARDS

See the figures and tables on the following pages for the correct connection of internal electrical and communications connections.

NOTE! The minimum optical cable bending radius is 50 mm.

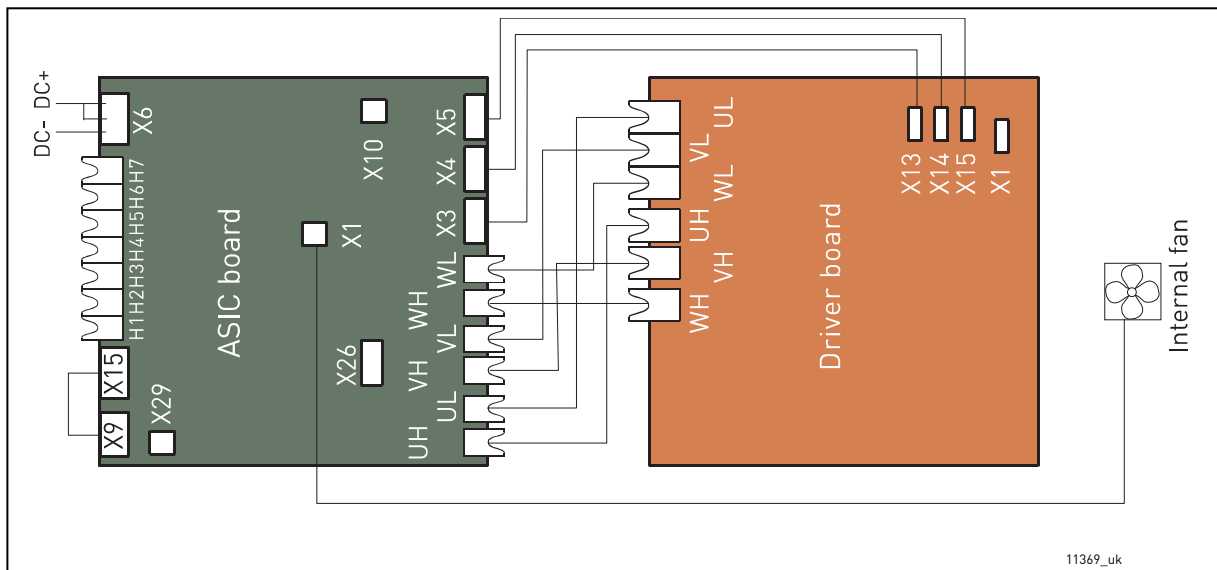

Figure 52. Terminals and connections between ASIC and driver board (CH61, CH62 and CH72)

Terminals on ASIC board	
X9	Charge feedback
X15	Charging relay output
X6	Connect to DC-link on AC drive
X29	Flow supervision input
X26	Star Coupler terminal for drives greater than CH61
X10	+24 V supply voltage to control board
X3	Connect to terminal X13 on driver board
X4	Connect to terminal X14 on driver board
X5	Connect to terminal X15 on driver board
X1	Driver board fan power connection

Gate driver signals from ASIC to driver board	
UH	Connect to UH on driver board
UL	Connect to UL on driver board
VH	Connect to VH on driver board
VL	Connect to VL on driver board
WH	Connect to WH on driver board
WL	Connect to WL on driver board
Terminal X1 on driver board	
X1	Connect to DC-link on AC drive

NOTE! Terminals X9 and X15 are connected by default. The cable can be removed if the signal is received from other source.

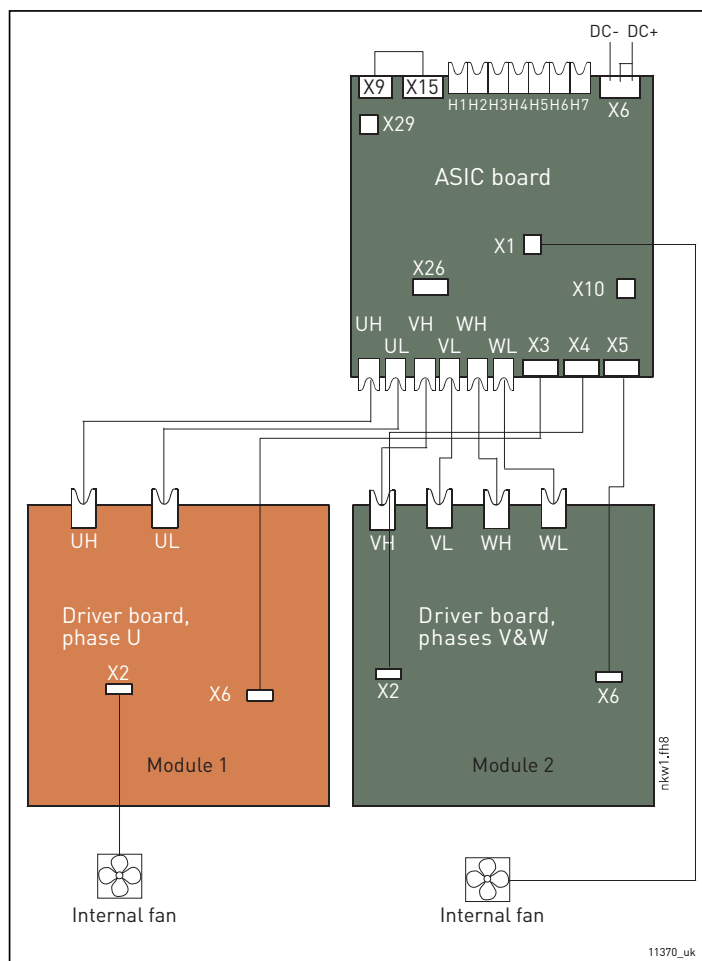

Figure 53. Terminals and connections between ASIC and driver boards (CH63)

Terminals on ASIC board		Gate driver signals from ASIC to driver board	
X9	Charge feedback	UH	Connect to UH on Phase U driver board
X15	Charging relay output	UL	Connect to UL on Phase U driver board
X6	Connect to DC-link on AC drive	VH	Connect to VH on Phase V/W driver board
X29	Flow supervision input	VL	Connect to VL on Phase V/W driver board
X26	Star Coupler terminal for drives greater than CH61	WH	Connect to WH on Phase V/W driver board
X10	+24 V supply voltage to control board	WL	Connect to WL on Phase V/W driver board
X3	Connect to terminal X6 on phase U driver board	Terminal X2 on Phase U driver board	
X4	Connect to terminal X2 on phase V/W driver board	X2	Internal fan power connection for Mod. 1

Terminals on ASIC board	
X5	Connect to terminal X6 on phase V/W driver board
X1	Internal fan power connection for Mod. 2

Gate driver signals from ASIC to driver board

NOTE! Terminals X9 and X15 are connected by default. The cable can be removed if the signal is received from other source.

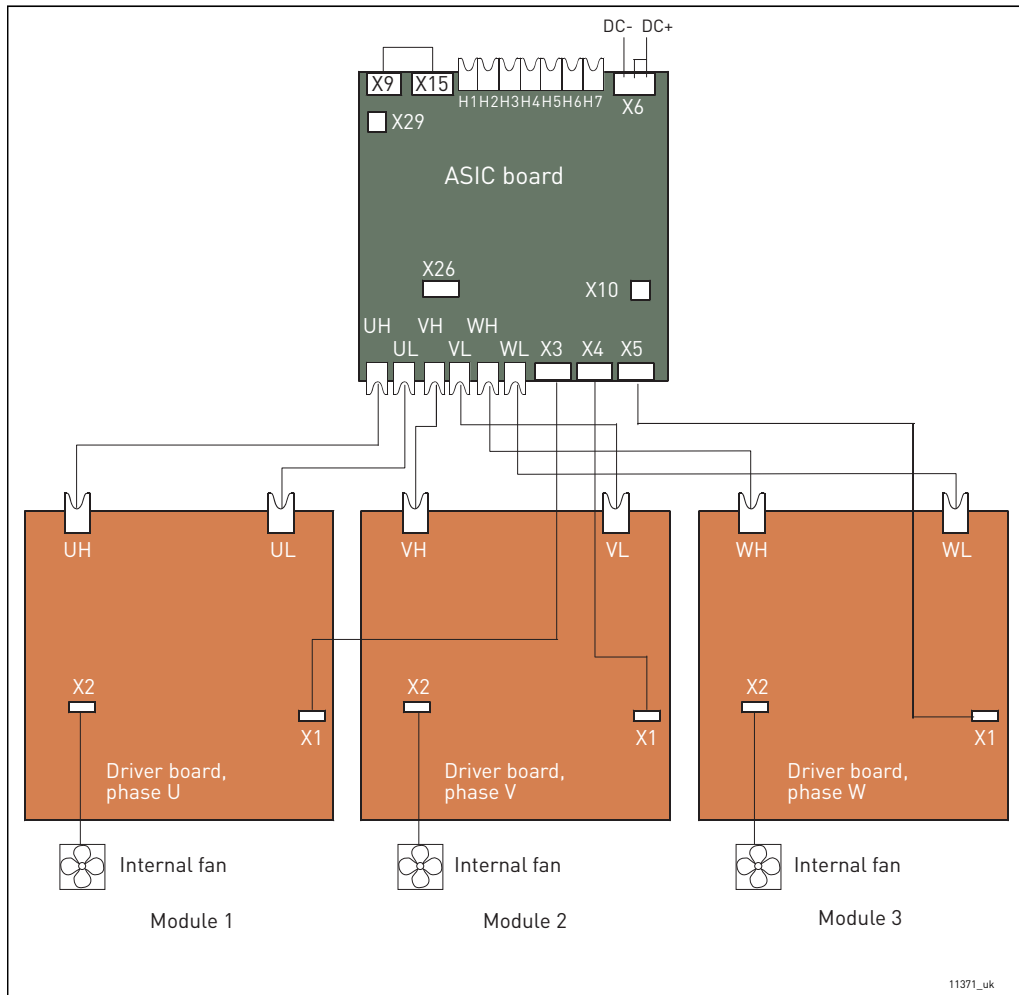

Figure 54. Terminals and connections between ASIC and driver boards (CH64 and CH74)

Terminals on ASIC board	
X9	Charge feedback
X15	Charging relay output
X6	Connect to DC-link on AC drive
X29	Flow supervision input
X26	Star Coupler terminal for drives greater than CH61

Gate driver signals from ASIC to driver board	
UH	Connect to UH on Phase U driver board
UL	Connect to UL on Phase U driver board
VH	Connect to VH on Phase V driver board
VL	Connect to VL on Phase V driver board
WH	Connect to WH on Phase W driver board

Terminals on ASIC board		Gate driver signals from ASIC to driver board	
X10	+24 V supply voltage to control board	WL	Connect to WL on Phase W driver board
X3	Connect to terminal X1 on phase U driver board	Terminal X2 on Phase driver board	
X4	Connect to terminal X1 on phase V driver board	X2	Internal fan power connection
X5	Connect to terminal X1 on phase W driver board		

NOTE! Terminals X9 and X15 are connected by default. The cable can be removed if the signal is received from other source.

6.3.2 CONNECTIONS BETWEEN POWER UNIT ASIC AND THE CONTROL UNIT

The communication connections between the VACON® NX Liquid-Cooled drive power unit and the control unit (see Chapter 6.2) can be established using either the conventional round cable (standard in chassis CH3, CH4 and CH5) or optical cable (all chassis). Note that for chassis CH61 and greater, only optical cables can be used.

6.3.2.1 Connections with round cable (Chassis CH3, CH4 and CH5)

The communication connection between the drive power unit and the control unit in chassis CH3, CH4 and CH5 are primarily made with conventional round cable and D-connectors at both ends.

Remove the protective cover to reveal the D-connector on the power unit. Connect the one end of the communication cable to the D-connector of the power unit and the other end to the control unit. If the Optical Cable Adapter Board (see below) sits on the D-connector of the control unit you have to remove it first. See Figure 55 below.

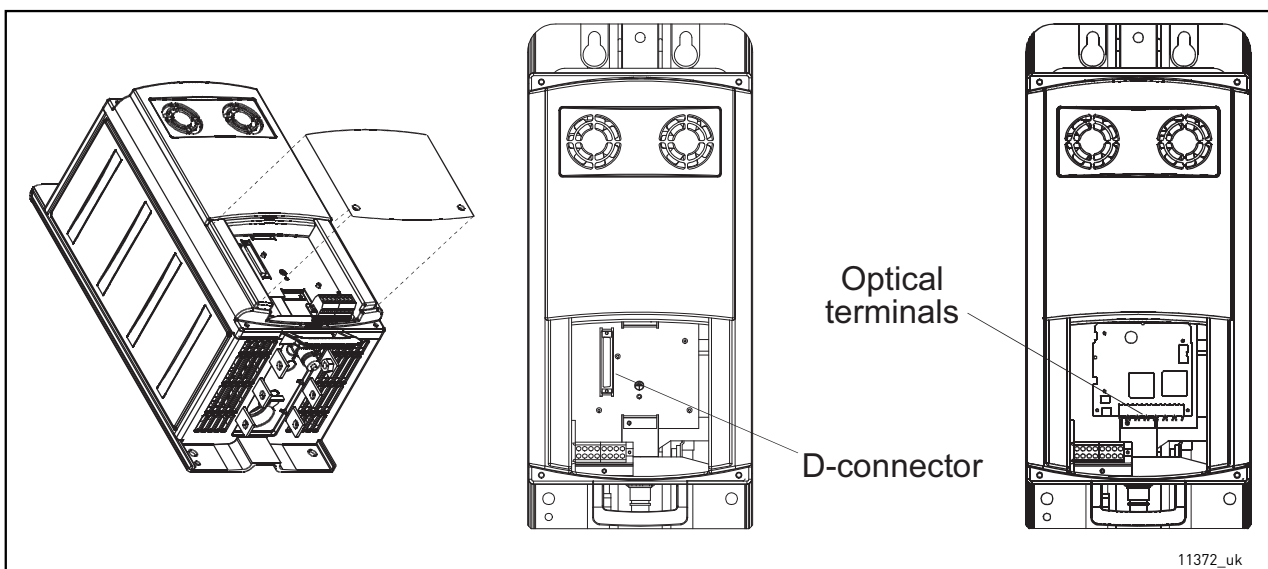

Figure 55.

6.3.2.2 Connections with optical cable (Chassis CH3, CH4, CH5, CH6x and CH7x)

If optical cables are used to link the power unit and the control board, a special Optical Cable Adapter Board connected to the control board D-connector must be used. To connect the optical cables to the power unit, you will have to remove the protective cover first. Connect the optical cables as shown in Figure 55 and Figure 56. See also Chapter 6.2.4.

The maximum length of the optical cable is 8 m.

The control unit uses 24 VDC supplied from the ASIC board, the location of which can be seen in the figures below. To access the board, remove the protective cover in front of the module. Connect the power supply cable to the X10 connector on the ASIC board and to the X2 connector on the rear side of the control unit.

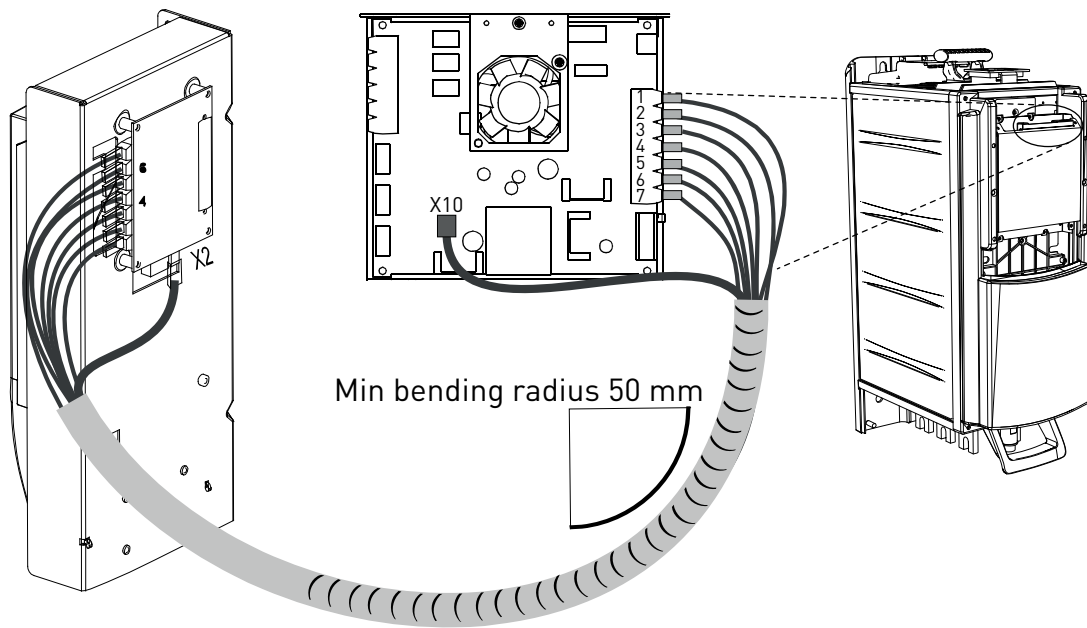

11310_uk

Figure 56. Connecting the power supply and control cables to the control unit, Ch6x

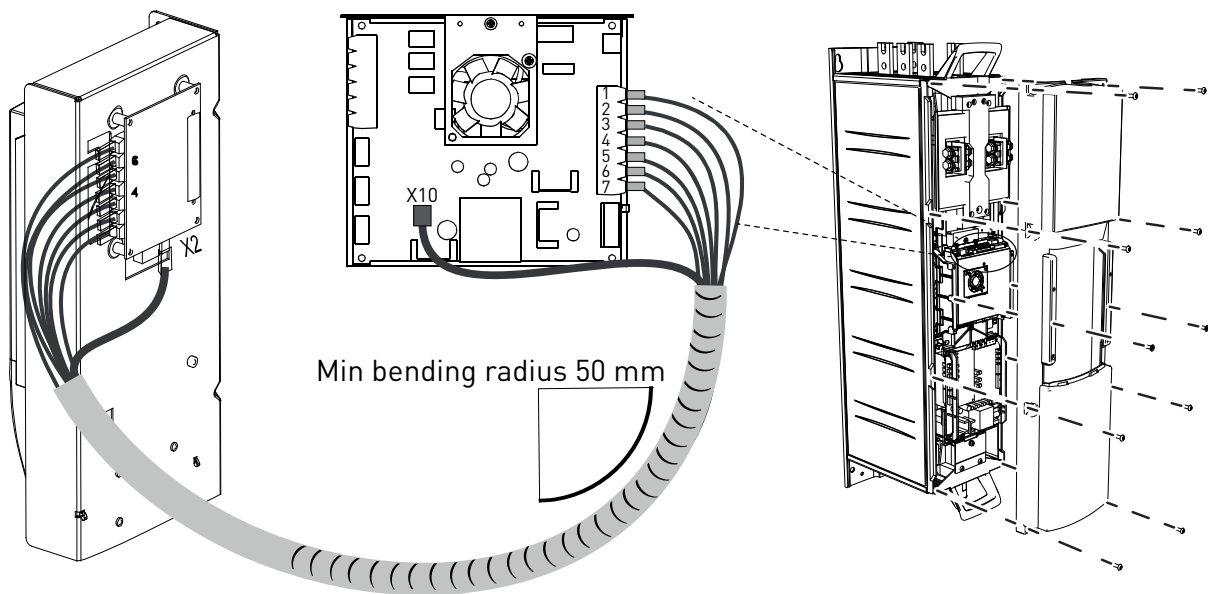

11297_uk

Figure 57. Connecting the power supply and control cables to the control unit, Ch7x

Each fibre optic cable has a number 1...7 marked on the cable shield at both cable ends. Connect each cable to the connectors marked with the same number 1...7 on the ASIC board and on the rear side of the control unit.

Optical terminals on Optical cable adapter board:

H1	Gate control enable
H2	Phase U control
H3	Phase V control
H4	Phase W control
H5	ADC synchronization
H6	VaconBus data from control board to ASIC
H7	VaconBus data from ASIC to control board

Other terminals on adapter board:

X1	Control board connection
X2	Supply voltage 24Vin (from power unit ASIC)
X3	Supply voltage 24Vin (customer); - Max. current 1A - Terminal #1: + - Terminal #2: -



CAUTION! Be careful when connecting the fibre optic cables!
Connecting the wires incorrectly
may damage power electronic components.

NOTE! The minimum optical cable bending radius is 50 mm.

NOTE! Terminals X2 and X3 can be in use simultaneously. However, if the +24 V supply from the control I/O terminals (e.g. from board OPT-A1) is used, this terminal must be protected with a diode.

Fix the cable bundle at two or more points, at least one at each end, to prevent damages to the cables.

Fasten the removed cover(s) on the inverter module when the work is finished.

6.3.2.3 Connections with optical cable (Chassis 2xCH64 and 2xCH74)

If optical cables are used to link the power unit and the control board, a special Optical Cable Adapter Board connected to the control board D-connector must be used. To connect the optical cables to the power unit, you will have to remove the protective cover first. Connect the optical cables as shown in Figure 59 and Figure 59. See also Chapter 6.2.4.

The maximum length of the optical cable is 8 m.

The control unit uses 24 VDC supplied from the ASIC board, which is located on the left side of the power unit 1. To access the board, remove the protective cover in front of the power module. Connect the power supply cable to the X10 connector on the ASIC board and to the X2 connector on the rear side of the control unit.

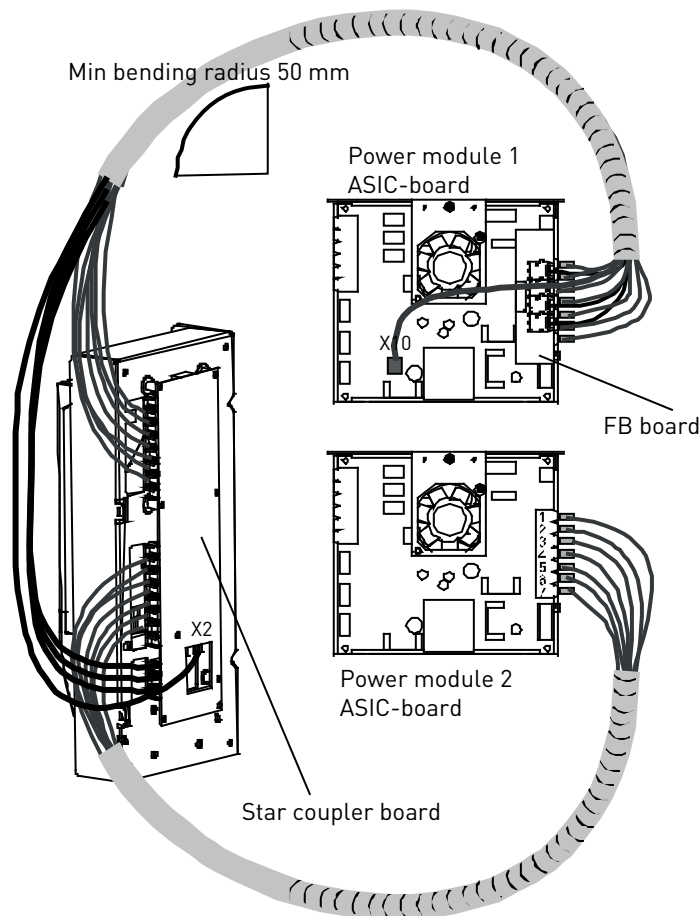

Figure 58. Connecting the power supply and control cables to the control unit, 2xCh64 and 2xCH74

Each fibre optic cable has a number 1...8 and 11...18 marked on the cable shield at both cable ends. Connect each cable to the connectors marked with the same number on the ASIC board and on the rear side of the control unit. Additionally, you may have to connect the 4 fibre cables from the feedback board to the star coupler board. The list of the optic signals can be found in Figure 59.

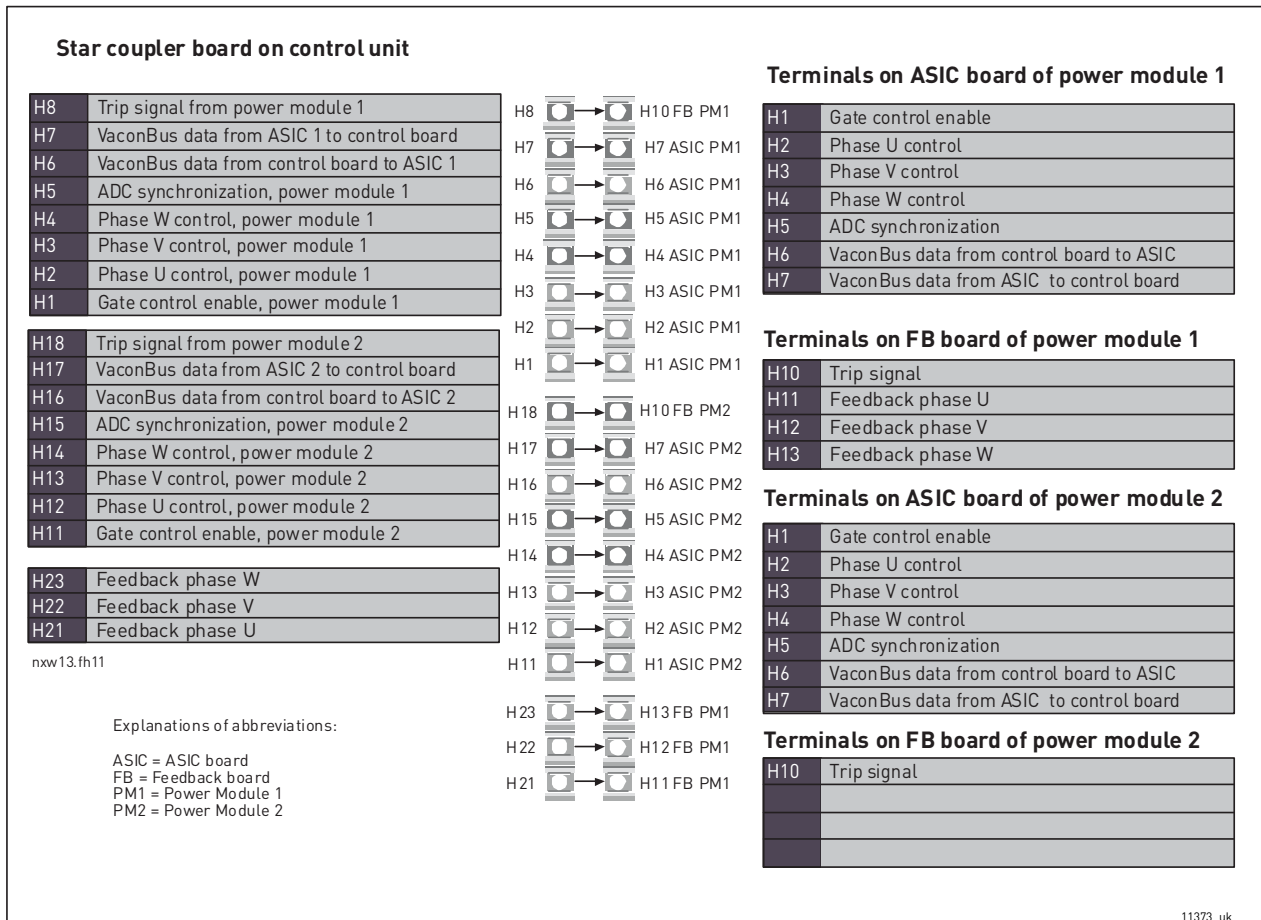

Figure 59. Terminals and connections between the star-coupler board, ASIC boards and feedback boards (CH64 and CH74)



Be careful when connecting the fibre optic cables! Connecting the wires incorrectly may damage power electronic components.

NOTE! The minimum optical cable bending radius is 50 mm.

NOTE! Terminals X2 and X3 can be in use simultaneously. However, if the +24 V supply from the control I/O terminals (e.g. from board OPT-A1) is used, this terminal must be protected with a diode.

Fix the cable bundle at two or more points, at least one at each end, to prevent damages to the cables.

Fasten the removed cover(s) on the inverter module when the work is finished.

6.3.3 CONNECTIONS BETWEEN MAINS DEVICE AND INVERTER POWER MODULE

The dimensions in the table below must be taken into account if some kind of mains device (e.g. fuse, switch fuse, contactor) is used in the input line between the mains and the VACON® Liquid-Cooled inverter.

Table 47. Connections from mains device to drive

Chassis	Type	Connection		
		Conductor cross section [mm ²]	Busbar size (flexible connection)	Busbar size (bare Cu)
CH3	0016_5	6		
	0022_5			
	0031_5			
CH3	0038_5	10		
	0045_5			
	0061_5			
CH4	0072_5	25		
	0087_5			
	0105_5			
CH4	0140_5	50		
CH5	0168_5	70	2*24*1	
CH5	0205_5	95		
CH5	0261_5	120		
CH61	0300_5	2*70	5*32*1	1*50*5
CH61	0385_5			
CH72	0460_5			
CH72	0520_5	2*120		
CH72	0590_5	2*150		
CH72	0650_5		2*(6*40*1)	1*80*5
CH72	0730_5			
CH63	0820_5			
CH63	0920_5			1*100*5
CH63	1030_5			
CH63	1150_5			
CH74	1370_5			2*100*5
CH74	1640_5			
CH74	2060_5			
CH74	2300_5			3*100*5

Table 48. Connections from mains device to drive

Chassis	Type	Connection		
		Conductor cross section [mm ²]	Busbar size (flexible connection)	Busbar size (bare Cu)
CH61	0170_6	70	2*24*1	
	0208_6	95		
	0261_6	120		
CH62	0325_6	2*70	5*32*1	1*50*5
	0385_6			
	0416_6	2*95		
	0460_6			
	0502_6	2*120		
CH63	0590_6	2*150	2*(6*40*1)	1*80*5
	0650_6			
	0750_6			
CH64	0820_6			1*100*5
	0920_6			
	1030_6			
	1180_6			
	1300_6			
	1500_6			

7. CONTROL KEYPAD

The control keypad is the link between the VACON® AC drive and the user. The VACON® NX control keypad features an alphanumeric display with seven indicators for the Run status (RUN, , READY, STOP, ALARM, FAULT) and three indicators for the control place (I/O term/ Keypad/ BusComm). There are also three Status Indicator LEDs (green - green - red), see below.

The control information, i.e. the number of menu, description of menu or the displayed value and the numeric information are presented on three text lines.

The AC drive is operable through the nine push-buttons of the control keypad. Furthermore, the buttons serve the purposes of parameter setting and value monitoring.

The keypad is detachable and isolated from the input line potential.

7.1 INDICATIONS ON THE KEYPAD DISPLAY

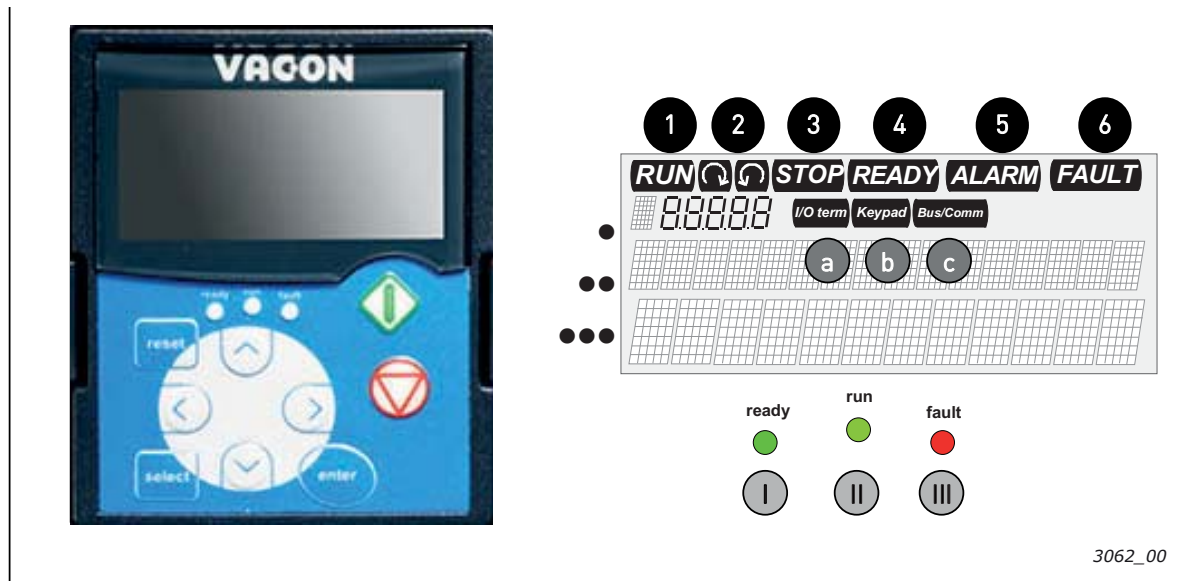



Figure 60. VACON® control keypad and drive status indications

7.1.1 DRIVE STATUS INDICATIONS

The drive status indications tell the user what the status of the motor and the drive is and whether the motor control software has detected irregularities in motor or AC drive functions.

- 1 RUN = Motor is running; Blinks when the stop command has been given but the frequency is still ramping down.
- 2  = Indicates the direction of motor rotation.
- 3 STOP = Indicates that the drive is not running.
- 4 READY = Lights when AC power is on. In case of a trip, the symbol will not light up.
- 5 ALARM = Indicates that the drive is running outside a certain limit and a warning is given.
- 6 FAULT = Indicates that unsafe operating conditions were encountered due to which the drive was stopped.

7.1.2 CONTROL PLACE INDICATIONS

The symbols I/O term, Keypad and Bus/Comm (see Figure 60) indicate the choice of control place made in the Keypad Control Menu (see Chapter 7.3.3).

- a** I/O term = I/O terminals are the selected control place; i.e. START/STOP commands or reference values etc. are given through the I/O terminals.
- b** Keypad = Control keypad is the selected control place; i.e. the motor can be started or stopped, or its reference values etc. altered from the keypad.
- c** Bus/Comm = The AC drive is controlled through a fieldbus.

7.1.3 STATUS LEDs (GREEN – GREEN – RED)

The status LEDs light up in connection with the READY, RUN and FAULT drive status indicators.

- I** ● = Illuminates with the AC power connected to the drive and no faults are active. Simultaneously, the drive status indicator READY is lit up.
- II** ● = Illuminates when the drive is running. Blinks when the STOP button has been pushed and the drive is ramping down.
- III** ● = Blinks when unsafe operating conditions were encountered due to which the drive was stopped (Fault Trip). Simultaneously, the drive status indicator FAULT blinks on the display and the fault description can be seen, see Chapter 7.3.4, Active Faults.

7.1.4 TEXT LINES

The three text lines (●, ●●, ●●●) provide the user with information on his present location in the keypad menu structure as well as with information related to the operation of the drive.

- = Location indication; displays the symbol and number of menu, parameter etc.
Example: M2 = Menu 2 (Parameters); P2.1.3 = Acceleration time
- = Description line; Displays the description of menu, value or fault.
- = Value line; Displays the numerical and textual values of references, parameters etc. and the number of submenus available in each menu.

7.2 KEYPAD PUSH-BUTTONS



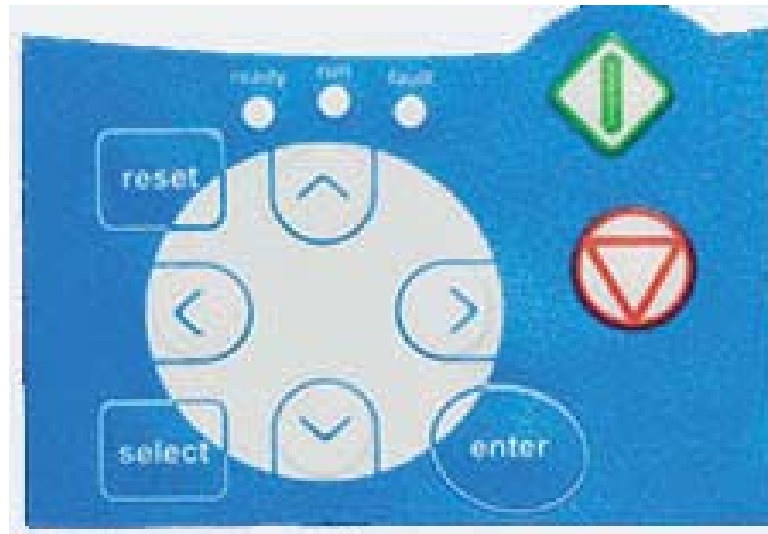







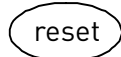

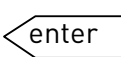



The VACON® alphanumeric control keypad features 9 push-buttons that are used for the control of the AC drive (and motor), parameter setting and value monitoring.





3063_00

Figure 61. Keypad push-buttons

7.2.1 BUTTON DESCRIPTIONS

-  = This button is used to reset active faults (see Chapter 7.3.4).
-  = This button is used to switch between two latest displays. May be useful when you want to see how the changed new value influences some other value.
-  = The Enter button serves for:
 - = 1) confirmation of selections
 - = 2) fault history reset (2...3 seconds)
-  = Browser button up
-  = Browse the main menu and the pages of different submenus. Edit values.
-  = Browser button down
-  = Browse the main menu and the pages of different submenus. Edit values.
-  = Menu button left
-  = Move backward in menu.
-  = Move cursor left (in parameter menu).
-  = Exit edit mode.
-  = Swap between keypad control and another control as active control place (see Chapter 7.2.1.1)
-  = Menu button right
-  = Move forward in menu.
-  = Move cursor right (in parameter menu).
-  = Enter edit mode.

-  = Start button
= Pressing this button starts the motor if the keypad is the active control place. See Chapter 7.3.3.
-  = Stop button. Pressing this button stops the motor (unless disabled by parameter R3.4/R3.6). See Chapter 7.3.3.

7.2.1.1 Swap between keypad control and another control as active control place

With the I/O terminals or fieldbus selected as the active control place, it is also possible to change the control to the local keypad and back to the original control place.

Irrespective of your location in the menu structure, keep the  button pushed down for 5 seconds. This will activate the Start & Stop keypad control. The display will jump to the editing mode of *R3.2 Keypad Reference* and you will be able to enter the desired frequency on the keypad. Push the start button to start the drive.

Pushing the  button again for 5 seconds returns the control to the original control place (active control place, P3.1) and its reference. **NOTE:** The motor starts if the start command of the active control place is ON and run at the formerly set reference. The keypad display will show monitoring value *V1.1 Output Frequency*.

If any of the parameter values in menu M3 is changed in between the swapping the keypad reference will be reset to 0.00 Hz.

7.3 NAVIGATION ON THE CONTROL KEYPAD

The data on the control keypad are arranged in menus and submenus. The menus are used for example for the display and editing of measurement and control signals, parameter settings (Chapter 7.3.2), reference values and fault displays (Chapter 7.3.4). Through the menus, you can also adjust the contrast of the display (page 137).

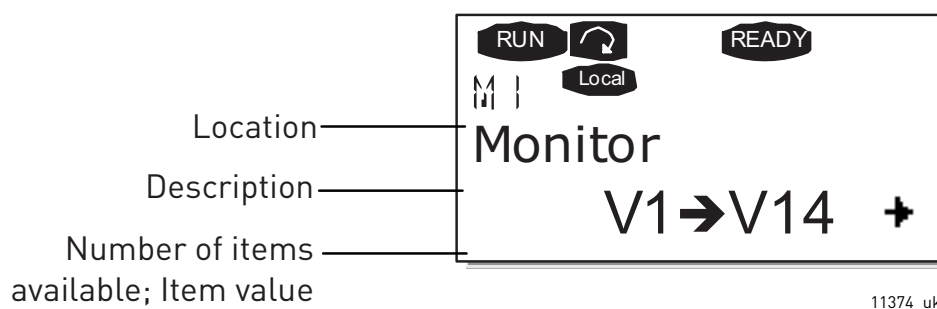

The first menu level consists of menus M1 to M7 and is called the Main menu. The user can navigate in the main menu using the Browser buttons up and down. The desired submenu can be entered from the main menu using the Menu buttons. When there still are pages to enter under the currently displayed menu or page, you can see an arrow (➔) in the lower right corner of the display and by pressing the Menu button right, you can reach the next menu level.

The control keypad navigation chart is shown on the next page. Note that the menu M1 is located in the lower left corner. From there you will be able to navigate your way up to the desired menu using the menu and browser buttons.

More detailed descriptions of the menus you will find later in this Chapter.

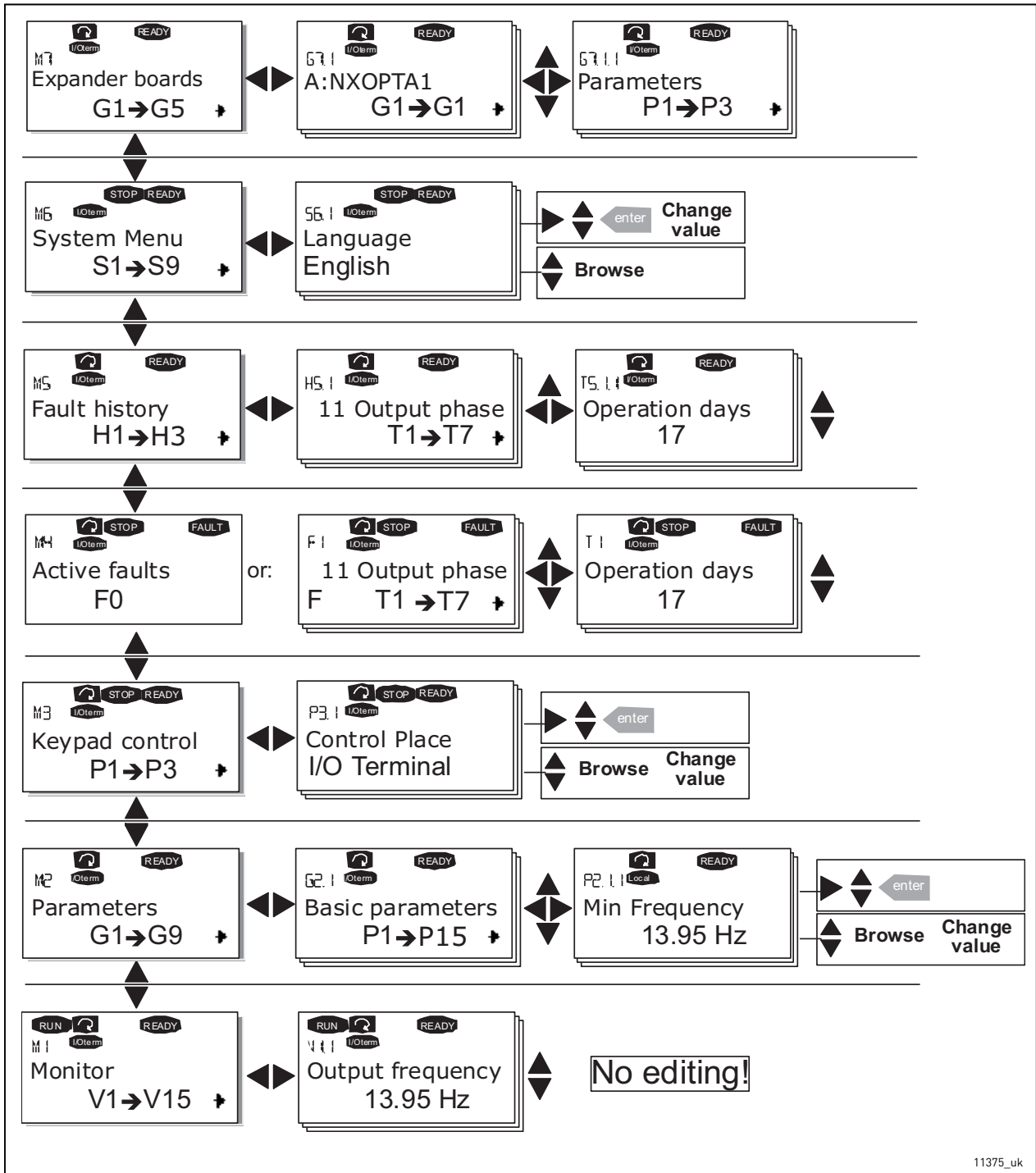

Figure 62. Keypad navigation chart

7.3.1 MONITORING MENU (M1)

You can enter the Monitoring menu from the Main menu by pushing the Menu button right when the location indication M1 is visible on the first line of the display. How to browse through the monitored values is presented in Figure 63.

The monitored signals carry the indication V#.# and they are listed in Table 49. The values are updated once every 0.3 seconds.

This menu is meant only for signal checking. The values cannot be altered here. For changing values of parameters see Chapter 7.3.2.

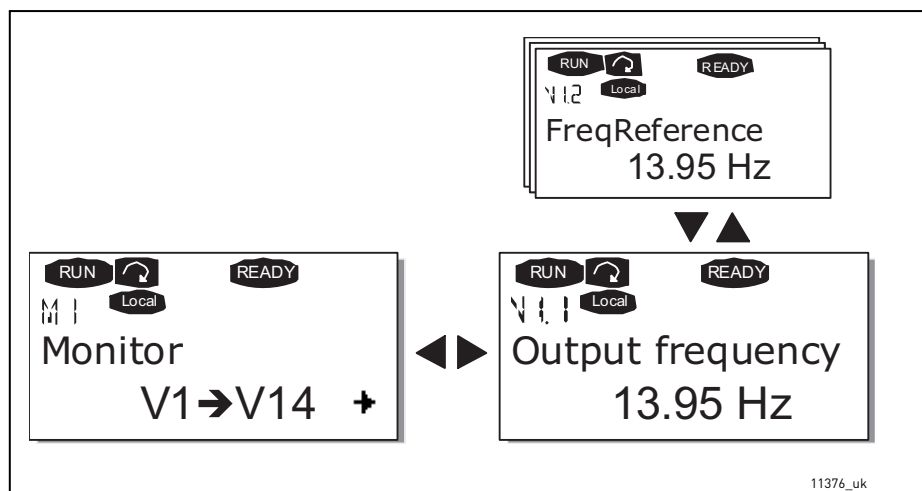

Figure 63. Monitoring menu

Table 49. Monitored signals

Code	Signal name	Unit	Description
V1.1	Output frequency	Hz	Frequency to the motor
V1.2	Frequency reference	Hz	
V1.3	Motor speed	rpm	Calculated motor speed
V1.4	Motor current	A	Measured motor current
V1.5	Motor torque	%	Calculated motor shaft torque
V1.6	Motor power	%	Calculated motor shaft power
V1.7	Motor voltage	V	Calculated motor voltage
V1.8	DC-link voltage	V	Measured DC-link voltage
V1.9	Unit temperature	°C	Heat sink temperature
V1.10	Motor temperature	%	Calculated motor temperature. See VACON [®] NX All in One application manual.
V1.11	Voltage input	V	A11
V1.12	Current input	mA	A12
V1.13	DIN1, DIN2, DIN3		Digital input statuses
V1.14	DIN4, DIN5, DIN6		Digital input statuses
V1.15	DO1, RO1, RO2		Digital and relay output statuses
V1.16	Analogue output current	mA	A01
V1.17	Multimonitoring items		Displays three selectable monitoring values. See Chapter 7.3.6.5.

NOTE! The All in One applications embody more monitoring values.

7.3.2 PARAMETER MENU (M2)

Parameters are the way of conveying the commands of the user to the AC drive. The parameter values can be edited by entering the Parameter Menu from the Main Menu when the location indication M2 is visible on the first line of the display. The value editing procedure is presented in Figure 64.

Push the Menu button right once to move into the Parameter Group Menu (G#). Locate the parameter group desired by using the Browser buttons and push the Menu button right again to enter the group and its parameters. Use again the Browser buttons to find the parameter (P#) you want to edit. From here you can proceed in two different ways: Pushing the Menu button right takes you to the edit mode. As a sign of this, the parameter value starts to blink. You can now change the value in two different manners:

1. Just set the new desired value with the Browser buttons and confirm the change with the Enter button. Consequently, the blinking stops and the new value is visible in the value field.
2. Push the Menu button right once again. Now you will be able to edit the value digit by digit. This editing manner may come in handy, when a relatively greater or smaller value than that on the display is desired. Confirm the change with the Enter button.

The value will not change unless the Enter button is pushed. Pressing the Menu button left takes you back to the previous menu.

Several parameters are locked, i.e. uneditable, when the drive is in RUN status. If you try to change the value of such a parameter the text *Locked* will appear on the display. The AC drive must be stopped in order to edit these parameters.

The parameters values can also be locked using the function in menu M6 (see Chapter Parameter lock (P6.5.2)).

You can return to the Main menu anytime by pressing the Menu button left for 3 seconds.

The basic application package "All in One+" includes seven applications with different sets of parameters.

Once in the last parameter of a parameter group, you can move directly to the first parameter of that group by pushing the Browser button up.

See the diagram for parameter value change procedure on page 123.

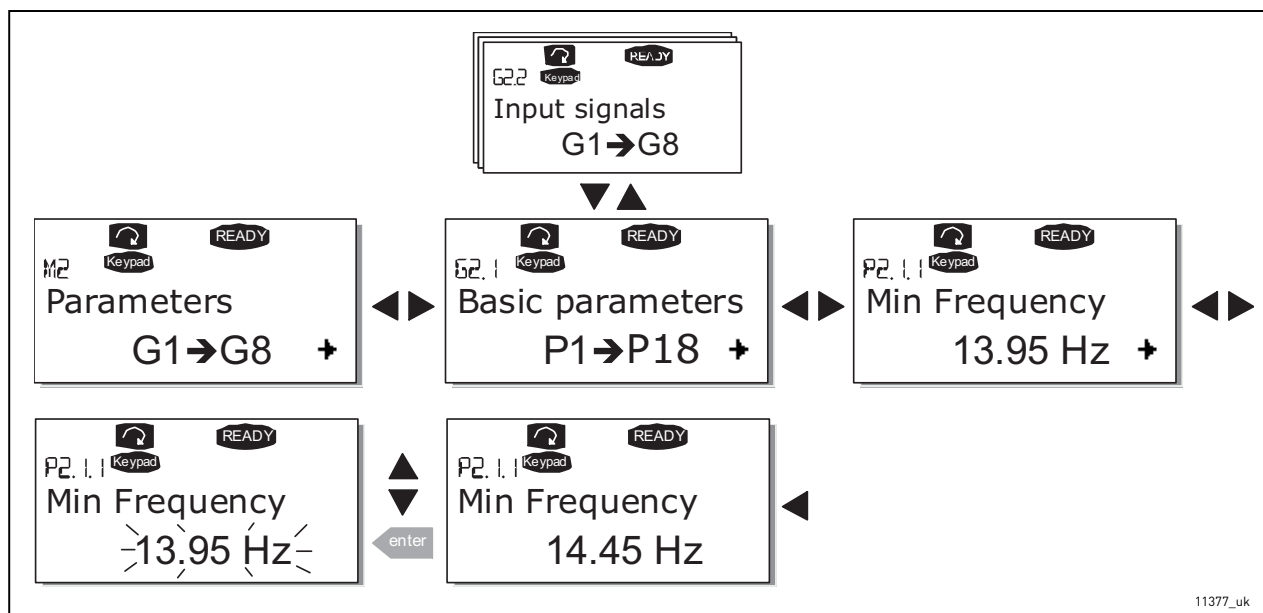

Figure 64. Parameter value change procedure

7.3.3 KEYPAD CONTROL MENU (M3)

In the Keypad Controls Menu, you can choose the control place, edit the frequency reference and change the direction of the motor. Enter the submenu level with the Menu button right.

Table 50. Keypad control parameters, M3

Code	Parameter	Min	Max	Unit	Default	Cust	ID	Note
P3.1	Control place	1	3		1		125	1 = I/O terminal 2 = Keypad 3 = Fieldbus
R3.2	Keypad reference	Par. 2.1.1	Par. 2.1.2	Hz				
P3.3	Direction (on keypad)	0	1		0		123	0 = Forward 1 = Reverse
R3.4	Stop button	0	1		1		114	0 = Limited function of Stop button 1 = Stop button always enabled

7.3.3.1 Selection of control place

There are three different places (sources) which the AC drive can be controlled from. For each control place, a different symbol will appear on the alphanumeric display:

Control place	symbol
I/O terminals	I/O term
Keypad (panel)	Keypad
Fieldbus	Bus/Comm

Change the control place by entering the edit mode with the Menu button right. The options can then be browsed through with the Browser buttons. Select the desired control place with the Enter button. See the diagram on the next page.

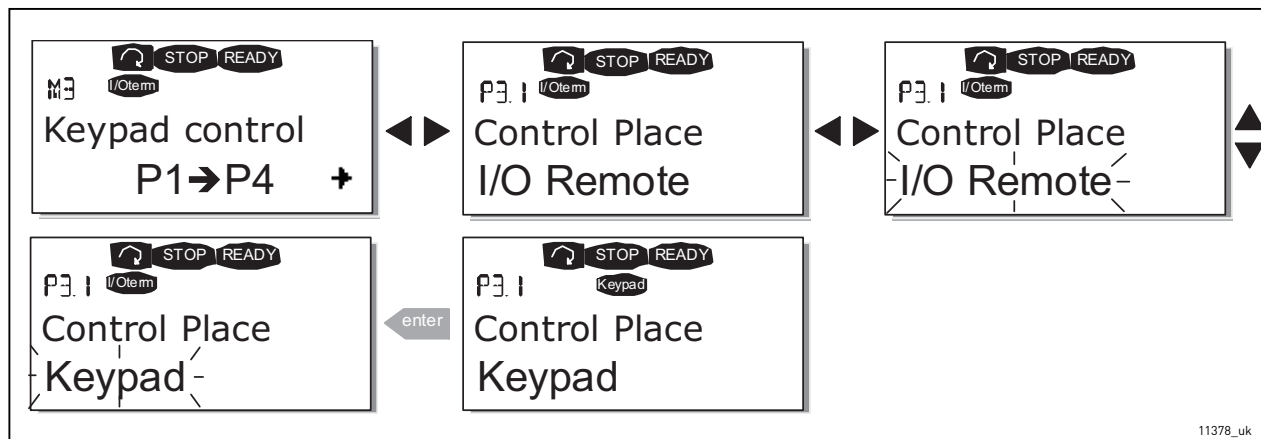

Figure 65. Selection of control place

7.3.3.2 Keypad reference

The keypad reference submenu (P3.2) displays and allows the operator to edit the frequency reference. The changes will take place immediately. This reference value will not, however, influence the rotation speed of the motor unless the keypad has been selected as source of reference.

NOTE! The maximum difference in RUN mode between the output frequency and the keypad reference is 6 Hz. See also Chapter 7.3.3.4 below.

See Figure 64 for how to edit the reference value (pressing the Enter button is not, however, necessary).

7.3.3.3 Keypad direction

The keypad direction submenu displays and allows the operator to change the rotating direction of the motor. This setting will not, however, influence the rotation direction of the motor unless the keypad has been selected as the active control place.

See also Chapter 7.3.3.4 below.

See Figure 65 for how to change the rotation direction.

NOTE! Additional Information on controlling the motor with the keypad is given in Chapter 7.2.1 and Chapter 8.2.

7.3.3.4 Stop button activated

By default, pushing the STOP button will always stop the motor regardless of the selected control place. You can disable this function by giving parameter 3.4 the value 0. If the value of this parameter

is 0, the STOP button will stop the motor only when the keypad has been selected as the active control place.

NOTE! There are some special functions that can be performed when in the M3 menu:

Select the keypad as the active control place by keeping the Start button pushed down for 3 seconds when the motor is running. The keypad will become the active control place and the current frequency reference and direction will be copied to the keypad.

Select the keypad as the active control place by keeping the Stop button pushed down for 3 seconds when the motor is stopped. The keypad will become the active control place and the current frequency reference and direction will be copied to the keypad.

Copy the frequency reference set elsewhere (I/O, fieldbus) to the panel by keeping the

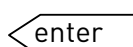
 pushed down for 3 seconds.

Note that if you are in any other than M3 menu these functions will not work.

If you are in some other than M3 menu and try to start the motor by pressing the START button when the keypad is not selected as the active control place you will get an error message Keypad Control NOT ACTIVE.

7.3.4 ACTIVE FAULTS MENU (M4)

The Active faults menu can be entered from the Main menu by pushing the Menu button right when the location indication M4 is visible on the first line of the keypad display.

When a fault brings the AC drive to a stop, the location indication F1, the fault code, a short description of the fault and the fault type symbol (see Chapter 7.3.4.1) will appear on the display. In addition, the indication FAULT or ALARM (see Figure 60 or Chapter 7.1.1) is displayed and, in case of a FAULT, the red led on the keypad starts to blink. If several faults occur simultaneously, the list of active faults can be browsed with the Browser buttons.

The memory of active faults can store the maximum of 10 faults in the order of appearance. The display can be cleared with the Reset button and the read-out will return to the same state it was before the fault trip. The fault remains active until it is cleared with the Reset button or with a reset signal from the I/O terminal or fieldbus.

NOTE! Remove external Start signal before resetting the fault to prevent unintentional restart of the drive.

Normal state,
no faults:



11379_uk

7.3.4.1 Fault types

In the VACON® NX AC drive, there are four different types of faults. These types differ from each other on the basis of the subsequent behaviour of the drive. See Table 51.

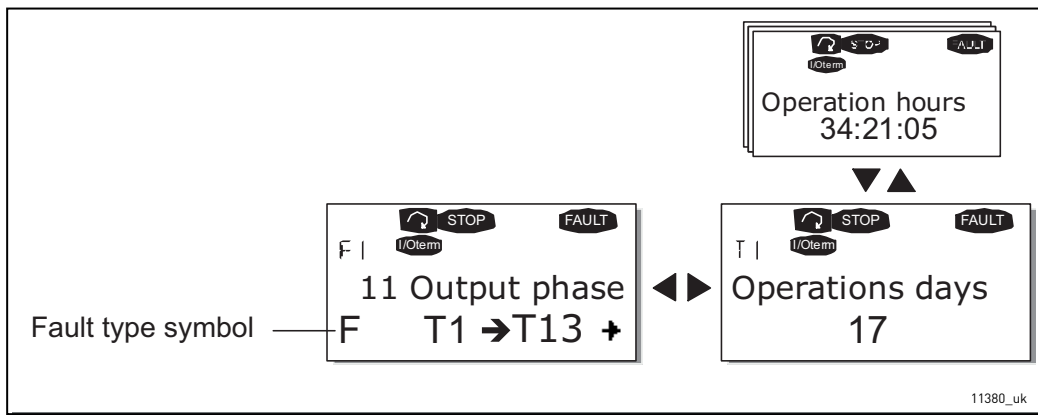

Figure 66. Fault display

Table 51. Fault types

Fault type symbol	Meaning
A (Alarm)	This type of fault is a sign of an unusual operating condition. It does not cause the drive to stop, nor does it require any special actions. The 'A fault' remains in the display for about 30 seconds.
F (Fault)	An 'F fault' is a kind of fault that makes the drive stop. Actions need to be taken in order to restart the drive.
AR (Fault Autoreset)	If an 'AR fault' occurs the drive will also stop immediately. The fault is reset automatically and the drive tries to restart the motor. Finally, if the restart is not successful, a fault trip (FT, see below) occurs.
FT (Fault Trip)	If the drive is unable to restart the motor after an AR fault an FT fault occurs. The effect of the 'FT fault' is basically the same as that of the F fault: the drive is stopped.

7.3.4.2 Fault codes

The fault codes, their causes and correcting actions are presented in Table 60. The shadowed faults are A faults only. The items written in white on black background present faults for which you can program different responses in the application. See parameter group Protections.

NOTE! When contacting distributor or factory because of a fault condition, always write down all texts and codes on the keypad display.

7.3.4.3 Fault time data record

When a fault occurs the information described above in is displayed. By pushing the Menu button right here you will enter the Fault time data record menu indicated by T.1→T.13. In this menu, some selected important data valid at the time of the fault are recorded. This feature is intended to help the user or the service person to determine the cause of fault.

The data available are:

Table 52. Fault time recorded data

T.1	Counted operation days (Fault 43: Additional code)	d
T.2	Counted operation hours (Fault 43: Counted operation days)	hh:mm:ss (d)
T.3	Output frequency (Fault 43: Counted operation hours)	Hz (hh:mm:ss)
T.4	Motor current	A
T.5	Motor voltage	V
T.6	Motor power	%
T.7	Motor torque	%
T.8	DC voltage	V
T.9	Unit temperature	°C
T.10	Run status	
T.11	Direction	
T.12	Warnings	
T.13	0-speed*	
* Tells the user if the drive was at zero speed (< 0.01 Hz) when the fault occurred		

Real time record

If real time is set to run on the AC drive the data items T1 and T2 will appear as follows:

T.1	Counted operation days	yyyy-mm-dd
T.2	Counted operation hours	hh:mm:ss,sss

7.3.5 FAULT HISTORY MENU (M5)

The Fault history menu can be entered from the Main menu by pushing the Menu button right when the location indication M5 is visible on the first line of the keypad display. Find the fault codes in Table 60.

All faults are stored in the Fault history menu in which you can browse through them using the Browser buttons. Additionally, the Fault time data record pages are accessible at each fault. You can return to the previous menu anytime by pushing the Menu button left.

The memory of the AC drive can store a maximum of 30 faults in the order of appearance. The number of faults currently in the fault history is shown on the value line of the main page (H1→H#).

The order of the faults is indicated by the location indication in the upper left corner of the display. The latest fault carries the indication F5.1, the second latest F5.2 etc. If there are 30 uncleared faults in the memory the next occurring fault will erase the oldest from the memory.

Pressing the Enter button for about 2 to 3 seconds resets the whole fault history. Then, the symbol H# will change to 0.

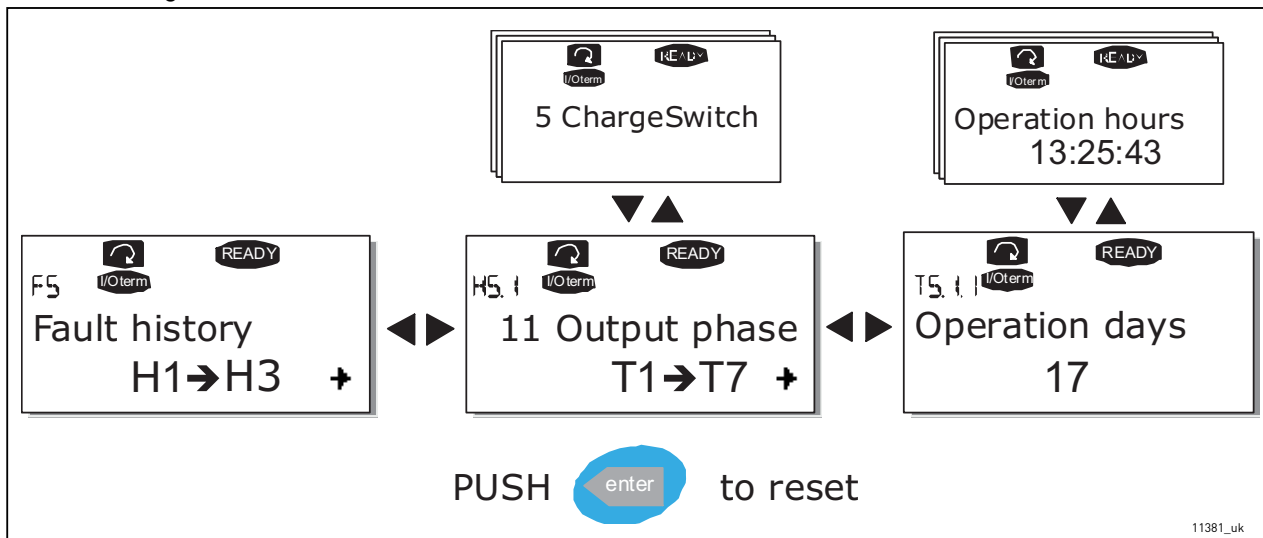

Figure 67. Fault history menu

7.3.6 SYSTEM MENU (M6)

The System menu can be entered from the main menu by pushing the Menu button right when the location indication M6 is visible on the display.

The controls associated with the general use of the AC drive, such as application selection, customised parameter sets or information about the hardware and software are located under the System menu. The number of submenus and subpages is shown with the symbol S (or P) on the value line.

On page 129 you will find a list of the functions available in the System menu.

Functions in the System menu

Table 53. System menu functions

Code	Function	Min	Max	Unit	Default	Cust	Selections
S6.1	Language selection				English		Available selections depend on the language package.
S6.2	Application selection				Basic Application		Basic Application Standard Application Local/Remote control Appl. Multi-Step Application PID Control Application Multi-Purpose Control Appl. Pump and Fan Control Appl.
S6.3	Copy parameters						
S6.3.1	Parameter sets						Store set 1 Load set 1 Store set 2 Load set 2 Load factory defaults
S6.3.2	Load up to keypad						All parameters
S6.3.3	Load down from keypad						All parameters All but motor parameters Application parameters
P6.3.4	Parameter backup				Yes		Yes No
S6.4	Compare parameters						
S6.4.1	Set1				Not used		
S6.4.2	Set2				Not used		
S6.4.3	Factory settings						
S6.4.4	Keypad set						
S6.5	Security						
S6.5.1	Password				Not used		0 = Not used
P6.5.2	Parameter lock				Change Enabled		Change Enabled Change Disabled
S6.5.3	Start-up wizard						No Yes
S6.5.4	Multimonitoring items						Change Enabled Change Disabled
S6.6	Keypad settings						
P6.6.1	Default page						
P6.6.2	Default page/ Operating menu						
P6.6.3	Timeout time	0	65535	s	30		
P6.6.4	Contrast	0	31		18		
P6.6.5	Backlight time	Always	65535	min	10		
S6.7	Hardware settings						
P6.7.3	HMI acknowlegd. timeout		200			5000	
P6.7.4	HMI number of retries		1			10	
S6.8	System information						

Table 53. System menu functions

Code	Function	Min	Max	Unit	Default	Cust	Selections
S6.8.1	Total counters						
C6.8.1.1	MWh counter						
C6.8.1.2	Power On day counter						
C6.8.1.3	Power On hours counter						
S6.8.2	Trip counters						
T6.8.2.1	MWh counter			kWh			
T6.8.2.2	Clear MWh trip counter						
T6.8.2.3	Operating days trip counter						
T6.8.2.4	Operating hours trip counter			hh:mm:ss			
T6.8.2.5	Clear operating time counter						
S6.8.3	Software info						
S6.8.3.1	Software package						
S6.8.3.2	System software version						
S6.8.3.3	Firmware interface						
S6.8.3.4	System load						
S6.8.4	Applications						
S6.8.4.#	Name of application						
D6.8.4.#.1	Application ID						
D6.8.4.#.2	Applications: Version						
D6.8.4.#.3	Applications: Firmware interface						
S6.8.5	Hardware						
I6.8.5.1	Info: Power unit type code						
I6.8.5.2	Info: Unit voltage			V			
I6.8.5.3	Info: Brake chopper						
I6.8.5.4	Info: Brake resistor						
S6.8.6	Expander boards						
S6.8.7	Debug menu						For Application programming only. Contact factory for more details.

7.3.6.1 Language selection

The VACON® control keypad offers you the possibility to control the AC drive through the keypad in the language of your choice.

Locate the language selection page under the System menu. Its location indication is S6.1. Press the Menu button right once to enter the edit mode. As the name of the language starts to blink you are able to choose another language for the keypad texts. Confirm the selection by pushing the Enter button. The blinking stops and all textual information on the keypad is presented in the language you chose.

You can return to the previous menu anytime by pushing the Menu button left.

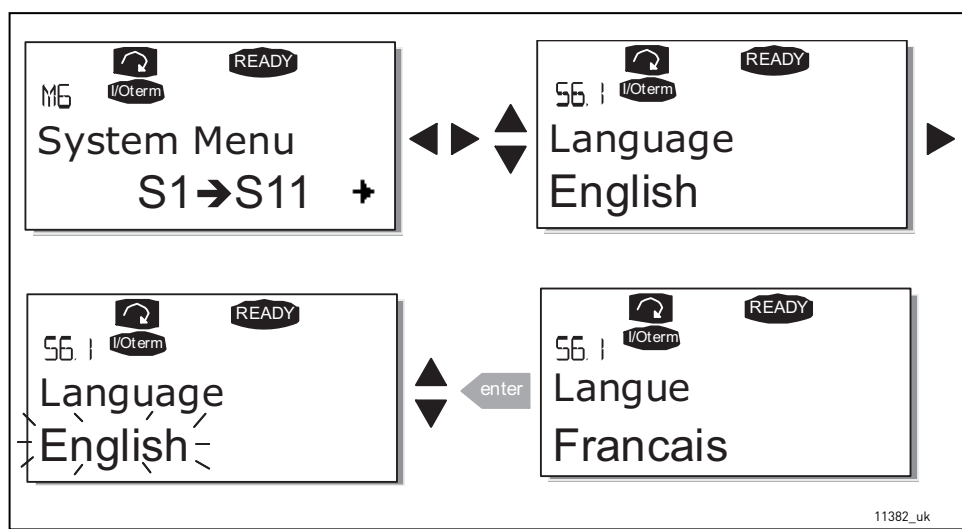

Figure 68. Selection of language

7.3.6.2 Application selection

The user can select the application desired by entering the Application selection page (S6.2). This is done by pushing the Menu button right when on the first page of the System menu. Change then the application by pushing the Menu button right once again. The name of the application starts to blink. Now you can browse through the applications with the Browser buttons and select another application with the Enter button.

Changing application will reset all parameters. After application change, you will be asked if you want the parameters of the new application to be uploaded to the keypad. If you wish this to happen push the Enter button. Pushing any other button leaves the parameters of the previously used application saved in the keypad. For more information, see Chapter 7.3.6.3.

For more information about the Application Package, see VACON® NX All-in-One Application Manual.

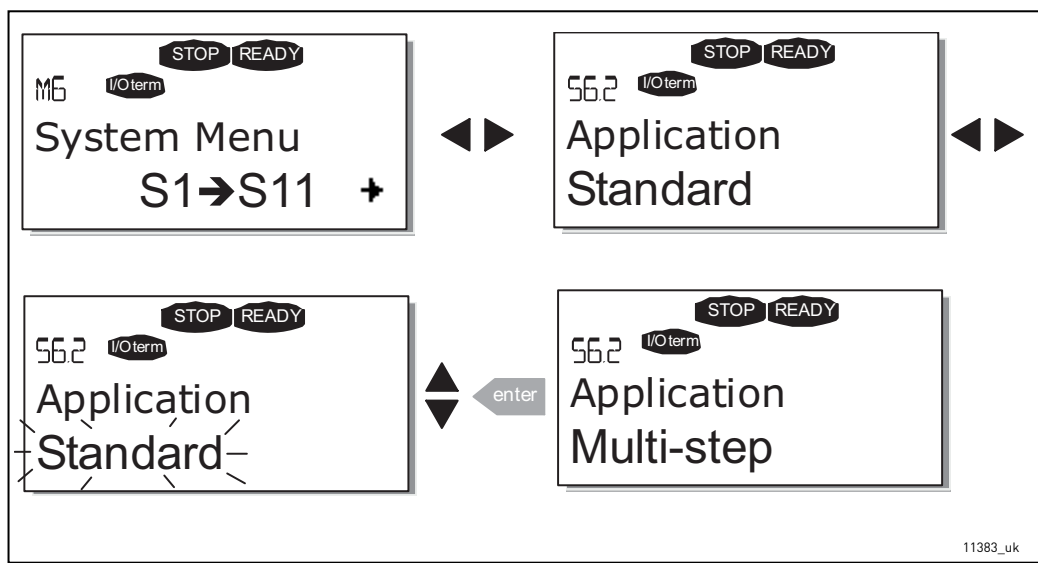

Figure 69. Change of application

7.3.6.3 Copy parameters

The parameter copy function is used when the operator wants to copy one or all parameter groups from one drive to another or to store parameter sets in the internal memory of the AC drive. All the parameter groups are first uploaded to the keypad, then the keypad is connected to another drive and then the parameter groups are downloaded to it (or possibly back to the same drive).

Before any parameters can successfully be copied from one drive to another the drive has to be stopped when the parameters are downloaded to it:

The parameter copy menu (S6.3) embodies four functions:

Parameter sets (S6.3.1)

The VACON® NX AC drive features a possibility for the user to load back the factory default parameter values and to store and load two customised parameter sets (all parameters included in the application).

On Parameter sets page (S6.3.1), push the Menu button right to enter the Edit menu. The text LoadFactDef begins to blink and you can confirm the loading of factory defaults by pushing the Enter button. The drive resets automatically.

Alternatively you can choose any other of the storing or loading functions with the Browser buttons. Confirm with the Enter button. Wait until 'OK' appears on the display.

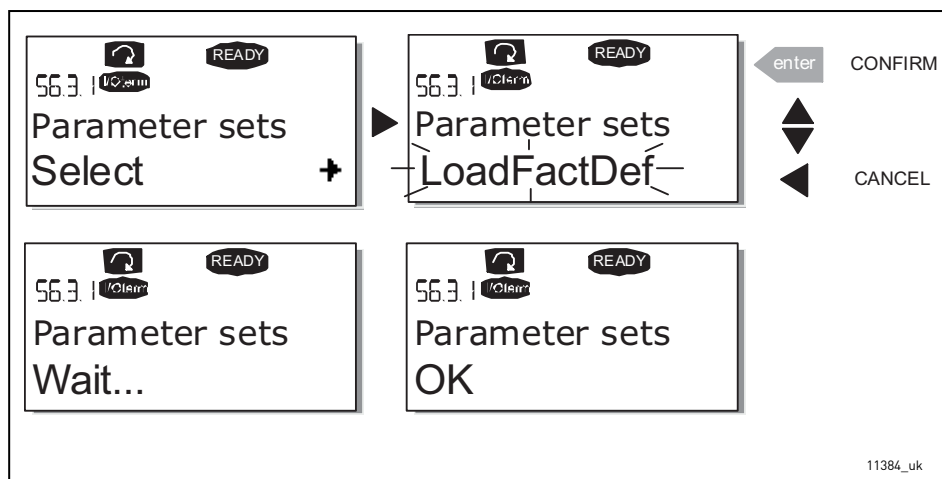

Figure 70. Storing and loading of parameter sets

Upload parameters to keypad (To keypad, S6.3.2)

This function uploads all existing parameter groups to the keypad provided that the drive is stopped.

Enter the To keypad page (S6.3.2) from the Parameter copy menu. Push the Menu button right to enter the edit mode. Use the Browser buttons to select the option All parameters and press the Enter button. Wait until 'OK' appears on the display.

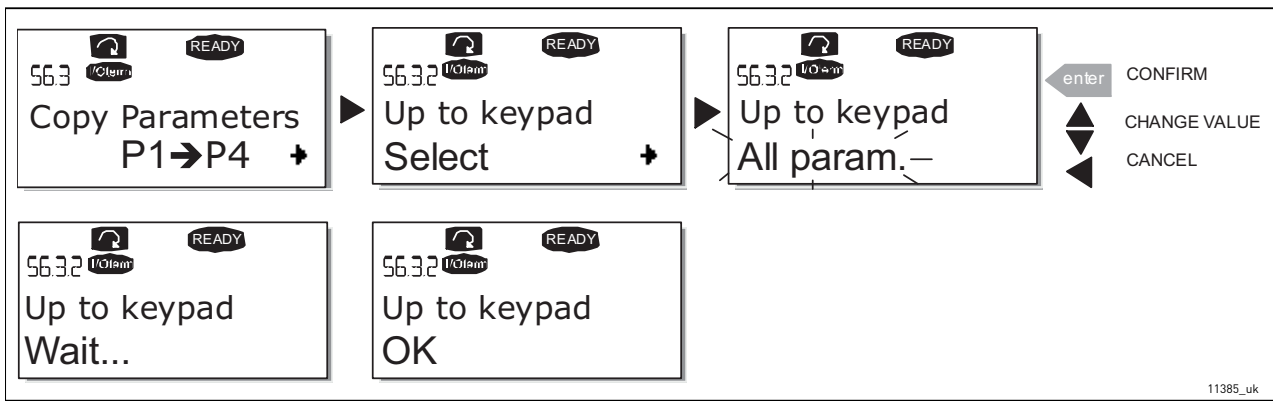

Figure 71. Parameter copy to keypad

Download parameters to drive (From keypad, S6.3.3)

This function downloads one or all parameter groups uploaded to the keypad to a drive provided that the drive is in STOP status.

Enter the From keypad page (S6.3.3) from the Parameter copy menu. Push the Menu button right to enter the edit mode. Use the Browser buttons to select either the option All parameters or Application parameters and press the Enter button. Wait until 'OK' appears on the display.

The procedure to download the parameters from keypad to drive is similar to that of from drive to keypad. See above.

Automatic parameter backup (P6.3.4)

On this page you can activate or inactivate the parameter backup function. Enter the edit mode by pressing the Menu button right. Choose Yes or No with the Browser buttons.

When the Parameter backup function is activated VACON® NX control keypad makes a copy of the parameters of the presently used application. Every time a parameter is changed the keypad backup is automatically updated.

When applications are changed, you will be asked if you wish the parameters of the new application to be uploaded to the keypad. For this to happen, push the Enter button. If you wish to keep the copy of the parameters of the previously used application saved in the keypad push any other button. Now you will be able to download these parameters to the drive following the instructions given in Chapter 7.3.6.3.

If you want the parameters of the new application to be automatically uploaded to the keypad you have to do this for the parameters of the new application once on page 6.3.2 as instructed. Otherwise the panel will always ask for the permission to upload the parameters.

NOTE! Parameters saved in the parameter settings on page S6.3.1 will be deleted when applications are changed. If you want to transfer the parameters from one application to another you have to upload them first to the keypad.

7.3.6.4 Parameter comparison

In the Parameter comparison submenu (S6.4), you can compare the actual parameter values to the values of your customised parameter sets and those loaded to the control keypad.

The comparison is performed by pushing the Menu button right when in the Compare parameters submenu. The actual parameter values are first compared to those of the customised parameter Set1. If no differences are detected a '0' is displayed on the lowermost line. But if any of the parameter values differ from those of the Set1 the number of the deviations is displayed together

with symbol P (e.g. P1→P5 = five deviating values). By pressing the Menu button right once again you can still enter the pages where you can see both the actual value and the value it was compared to. In this display, the value on the Description line (in the middle) is the default value and the one on the value line (lowermost) is the edited value. Furthermore, you can also edit the actual value with the Browser buttons in the edit mode that you can reach by pushing the Menu button right once again.

In the same way, you can perform the comparison of the actual values to Set2, Factory Settings and Keypad Set.

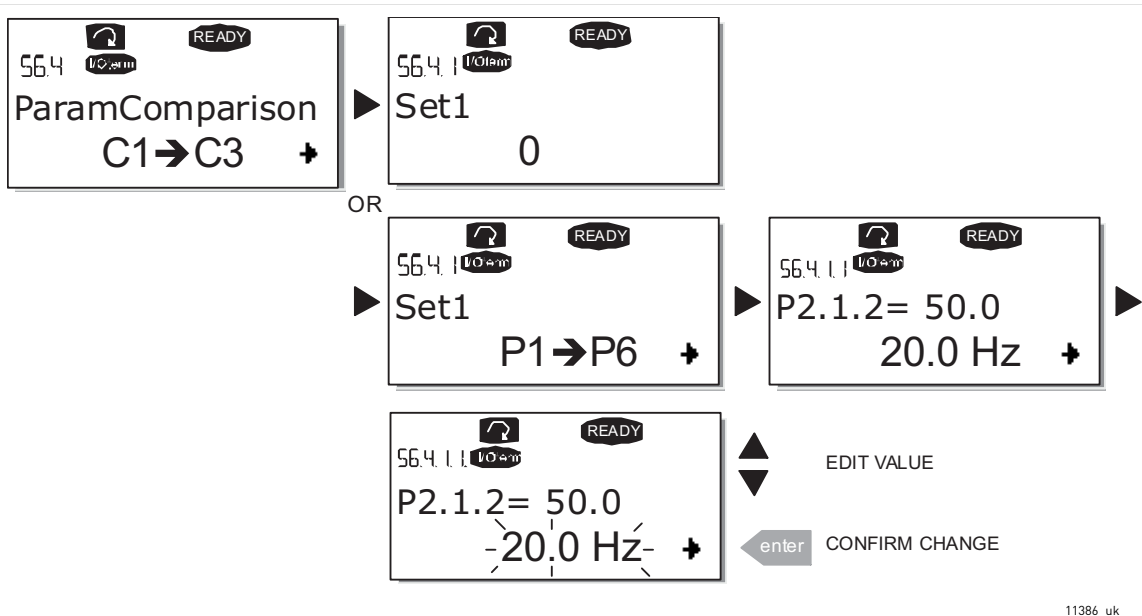

Figure 72. Parameter comparison

7.3.6.5 Security

NOTE! The Security submenu is protected with a password. Store the password in a safe place!

Password (S6.5.1)

The application selection can be protected against unauthorised changes with the Password function (S6.5.1).

By default, the password function is not in use. If you want to activate the function, enter the edit mode by pushing the Menu button right. A blinking zero appears in the display and now you can set a password with the Browser buttons. The password can be any number between 1 and 65535.

NOTE! that you can also set the password by digits. In the edit mode, push the Menu button right once again and another zero appears on the display. Now set first the units. Then push the Menu button left and you can set the tens etc. Finally, confirm the password setting with the Enter button. After this, you have to wait until the Timeout time (P6.6.3) (see page 137) has expired before the password function is activated.

If you now try to change applications or the password itself you will be prompted for the current password. The password will be entered with the Browser buttons.

Deactivate the password function by entering the value 0.

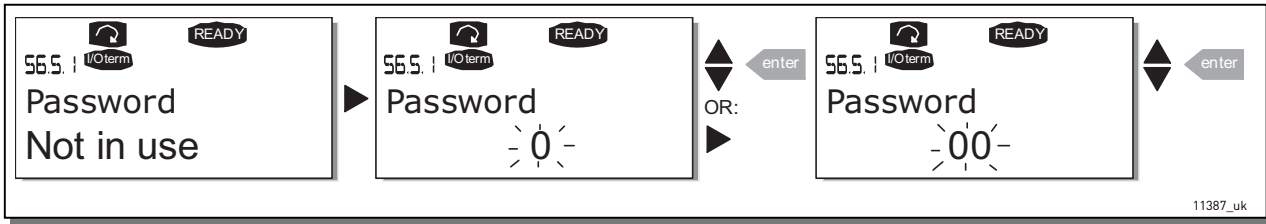

Figure 73. Password setting

NOTE! Store the password in a secure location! No changes can be made unless a valid password is entered!

Parameter lock (P6.5.2)

This function allows the user to prohibit changes to the parameters.

If the parameter lock is activated the text *locked* will appear on the display if you try to edit a parameter value.

NOTE! This function does not prevent unauthorised editing of parameter values.

Enter the edit mode by pushing the Menu button right. Use the Browser buttons to change the parameter lock status. Accept the change with the Enter button or return to the previous level with the Menu button left.

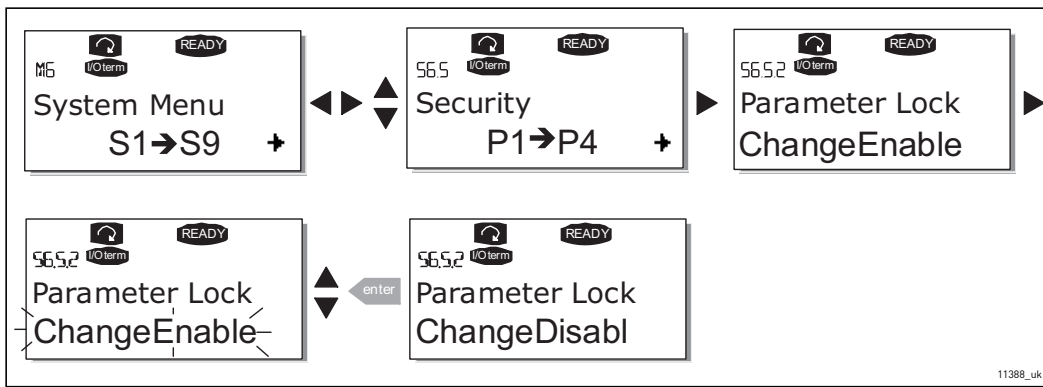

Figure 74. Parameter locking

Start-up Wizard (P6.5.3)

The Start-up Wizard is a feature on the control keypad to facilitate the commissioning of the AC drive. If selected active (default), the Start-up Wizard prompts the operator for the language and application of his/her choice plus for the values for a set of parameters common to all applications as well as for a set of application-dependent parameters.

Always accept the value with the Enter button, scroll options or change values with the Browser buttons (up and down arrows).

Set the Start-up Wizard active in the following way: In the System Menu, find page P6.5.3. Press the Menu button right once to reach the edit mode. Use the Browser buttons to set value Yes and confirm the selection with the Enter button. If you want to deactivate the function follow the same procedure and give the parameter value No.



Figure 75. Activation of Start-up wizard

Multimonitoring items (P6.5.4)

VACON® alpha-numeric keypad features a display where you can monitor even three actual values at the same time (see Chapter 7.3.1 and Chapter Monitoring values in the manual of the application you are using). On page P6.5.4 of the System Menu you can define if it is possible for the operator to replace the values monitored with other values. See below.

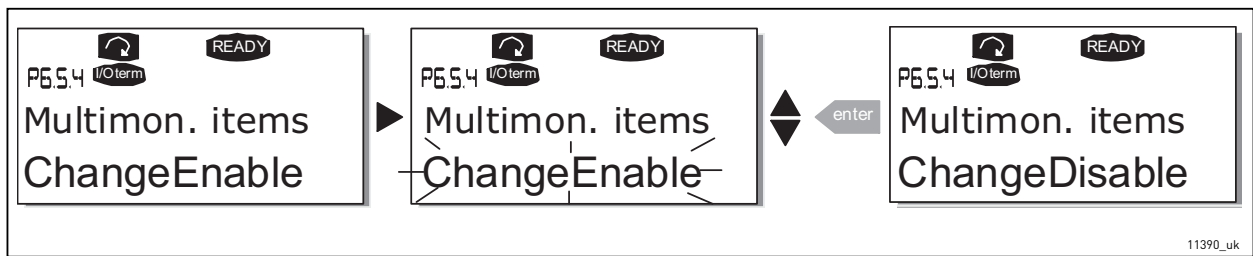

Figure 76. Enabling the change of multimonitoring items

7.3.6.6 Keypad settings

In the Keypad settings submenu under the System menu you can further customise your AC drive operator interface.

Locate the Keypad settings submenu (S6.6). Under the submenu, there are four pages (P#) associated with the keypad operation:

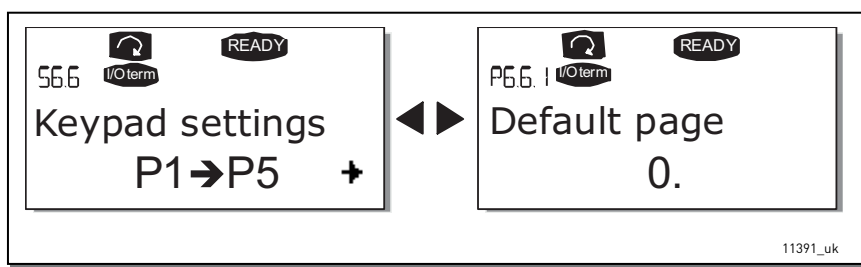

Figure 77. Keypad settings submenu

Default page (P6.6.1)

Here you can set the location (page) to which the display automatically moves as the Timeout time (see below) has expired or as the power is switched on to the keypad.

If the Default Page value is 0 the function is not activated, i.e. the last displayed page remains on the keypad display. Press the Menu button right once to enter the edit mode. Change the number of the Main menu with the Browser buttons. Pressing the Menu button right once again makes you able to edit the number of the submenu/page. If the page you want to move to by default is at the third level

repeat the procedure. Confirm the new default page value with the Enter button. You can return to the previous step anytime by pushing the Menu button left.

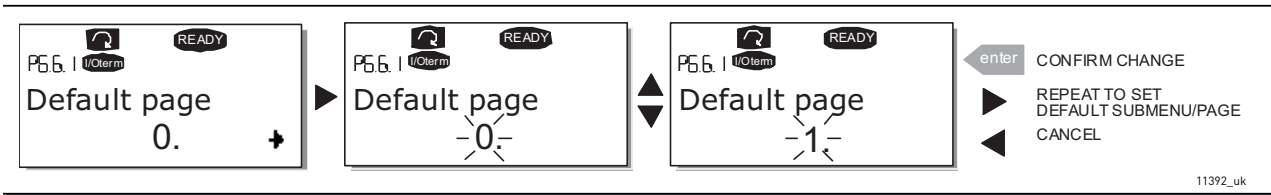

Figure 78. Default page function

Default page in the operating menu (P6.6.2)

Here you can set the location (page) in the Operating menu (in special applications only) to which the display automatically moves as the set Timeout time (see below) has expired or as the power is switched on to the keypad. See setting of Default page above.

Timeout time (P6.6.3)

The Timeout time setting defines the time after which the keypad display returns to the Default page (P6.6.1) see above.

Move to the Edit menu by pressing the Menu button right. Set the timeout time you want and confirm the change with the Enter button. You can return to the previous step anytime by pushing the Menu button left.

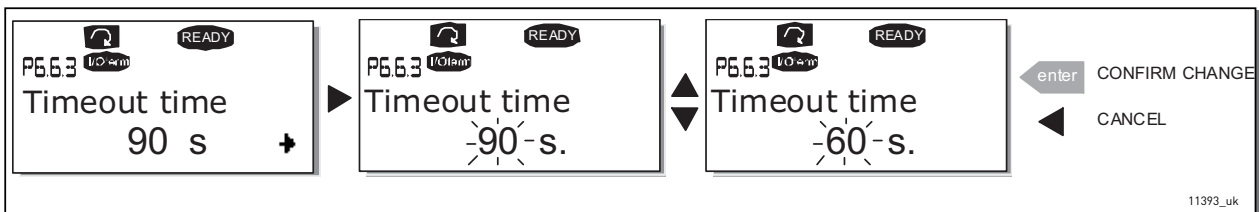

Figure 79. Timeout time setting

NOTE! If the Default page value is 0 the Timeout time setting has no effect.

Contrast adjustment (P6.6.4)

In case the display is unclear you can adjust its contrast through the same procedure as that for the timeout time setting (see above).

Backlight time (P6.6.5)

Giving a value for the Backlight time, you can determine how long the backlight stays on before going out. You can select here any time between 1 and 65535 minutes or 'Forever'. For the value setting procedure see Timeout time (P6.6.3).

7.3.6.7 Hardware settings

NOTE! The Hardware settings submenu is protected with a password (see Chapter Password (S6.5.1)). Store the password in a safe place!

In the Hardware settings submenu (S6.7) under the System menu you can further control some functions of the hardware in your AC drive. The functions available in this menu are HMI acknowledge timeout and HMI retry.

HMI acknowledge timeout (P6.7.3)

This function allows the user to change the timeout of the HMI acknowledgement time in cases where there is an additional delay in the RS-232 transmission due to use of modems for communication over longer distances, for example.

NOTE! If the AC drive has been connected to the PC with a normal cable, the default values of parameters 6.7.3 and 6.7.4 (200 and 5) must not be changed.

If the AC drive has been connected to the PC via a modem and there is delay in transferring messages, the value of par. 6.7.3 must be set according to the delay as follows:

Example:

- Transfer delay between the AC drive and the PC = 600 ms
- The value of par. 6.7.3 is set to 1200 ms (2 x 600, sending delay + receiving delay)
- The corresponding setting must be entered in the [Misc]-part of the file NCDrive.ini:

Retries = 5

AckTimeOut = 1200

TimeOut = 6000

It must also be considered that intervals shorter than the AckTimeOut-time cannot be used in NC-Drive monitoring.

Enter the edit mode by pushing the Menu button right. Use the Browser buttons to change the acknowledgement time. Accept the change with the Enter button or return to the previous level with the Menu button left.

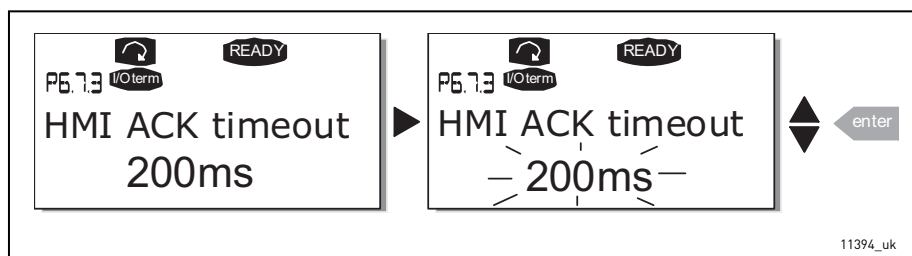

Figure 80. HMI acknowledge timeout

Number of retries to receive HMI acknowledgement (P6.7.4)

With this parameter you can set the number of times the drive will try receive acknowledgement if this does not succeed within the acknowledgement time (P6.7.3) or if the received acknowledgement is faulty.

Enter the edit mode by pushing the Menu button right. The present value shown starts to blink. Use the Browser buttons to change the amount of retries. Accept the change with the Enter button or return to the previous level with the Menu button left.

See Figure 80 for the procedure of changing the value.

7.3.6.8 System info

In the System info submenu (S6.8) you can find AC drive-related hardware and software information as well as operation-related information.

Total counters (S6.8.1)

In the Total counters page (S6.8.1) you can find information related to the AC drive operation times, i.e. the total numbers of MWh, operation days and operation hours passed so far. Unlike the counters in the Trip counters, these counters cannot be reset.

NOTE! The Power On time counter (days and hours) runs always, when the power is on.

Table 54. Counter pages

Page	Counter	Example
C6.8.1.1.	MWh counter	
C6.8.1.2.	Power On day counter	Value on display is 1.013. The drive has operated for 1 year and 13 days.
C6.8.1.3.	Power On hour counter	Value on display is 7:05:16. The drive has operated for 7 hours 5 minutes and 16 seconds.

Trip counters (S6.8.)

Trip counters (menu S6.8.2) are counters the values of which can be reset i.e. restored to zero. You have the following resettable counters at your disposal. See Table 54 for examples.

NOTE! The trip counters run only when the motor is running.

Table 55. Resettable counters

Page	Counter
T6.8.2.1	MWh counter
T6.8.2.3	Operation day counter
T6.8.2.4	Operation hour counter

The counters can be reset on pages 6.8.2.2 (Clear MWh counter) and 6.8.2.5 (Clear Operation time counter).

Example: When you want to reset the operation counters you should do the following:

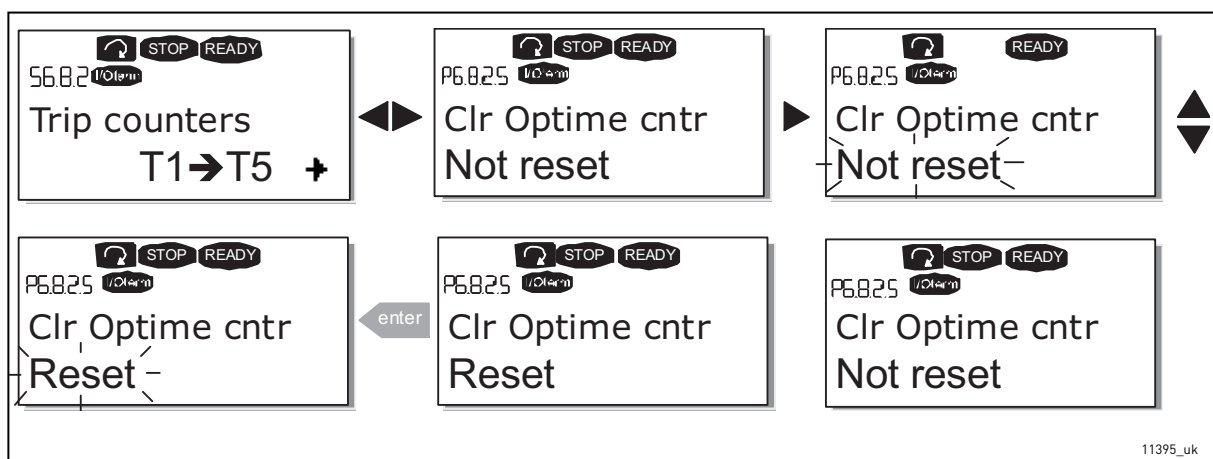

Figure 81. Counter reset

Software (S6.8.3)

The Software information page includes information on the following AC drive software related topics:

Table 56. Software information pages

Page	Content
6.8.3.1	Software package
6.8.3.2	System software version
6.8.3.3	Firmware interface
6.8.3.4	System load

Applications (S6.8.4)

At location S6.8.4 you can find the Applications submenu containing information about not only the application currently in use but also all other applications loaded into the AC drive. The information available is:

Table 57. Applications information pages

Page	Content
6.8.4.#	Name of application
6.8.4.#.1	Application ID
6.8.4.#.2	Version
6.8.4.#.3	Firmware interface

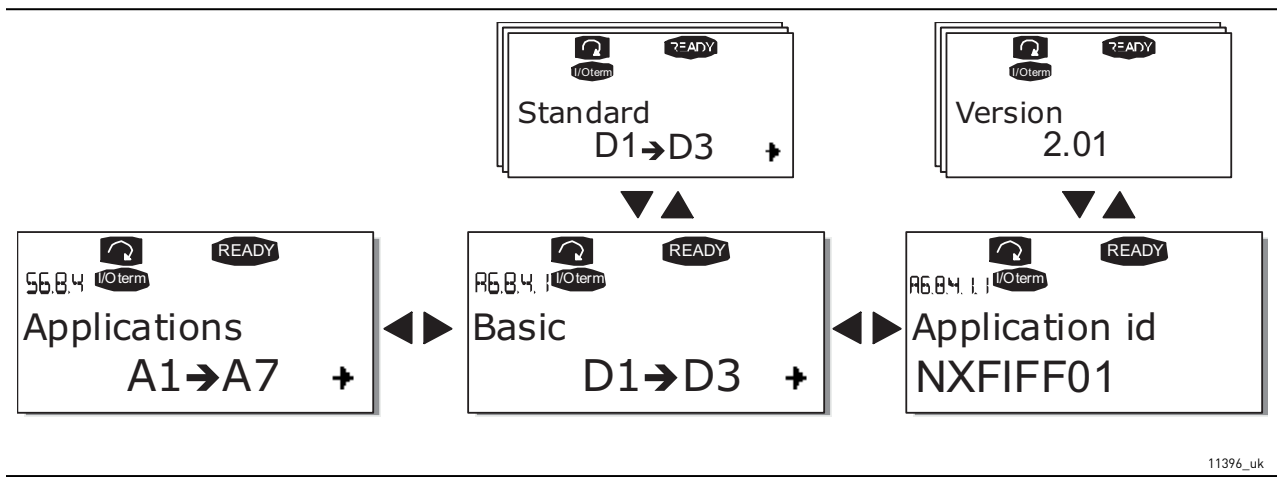

Figure 82. Applications info page

In the Applications information page, push the Menu button right to enter the Application pages of which there are as many as there are applications loaded into the AC drive. Locate the application you want information about with the Browser buttons and then enter the Information pages with the Menu button right. Use again the Browser buttons to see the different pages.

Hardware (S6.8.5)

The Hardware information page provides information on the following hardware-related topics:

Table 58. Hardware information pages

Page	Content
6.8.5.1	Power unit type code
6.8.5.2	Nominal voltage of the unit
6.8.5.3	Brake chopper
6.8.5.4	Brake resistor

Expander boards (S6.8.6)

In the Expander boards pages you find information about the basic and option boards connected to the control board (see Chapter 6.1.2).

You can check the status of each board slot by entering the Expander boards page with the Menu button right and using the Browser buttons to choose the board whose status you wish to check. Push the Menu button right again to display the status of the board. The keypad will also display the program version of the respective board when you push either one of the Browser buttons.

If no board is connected to the slot the text 'no board' will be shown. If a board is connected to a slot but the connection is somehow lost the text 'no conn.' is displayed. See Chapter 6.2 and Figure 41 and Figure 50 for more information.

For more information on the expander board-related parameters, see Chapter 7.3.7.

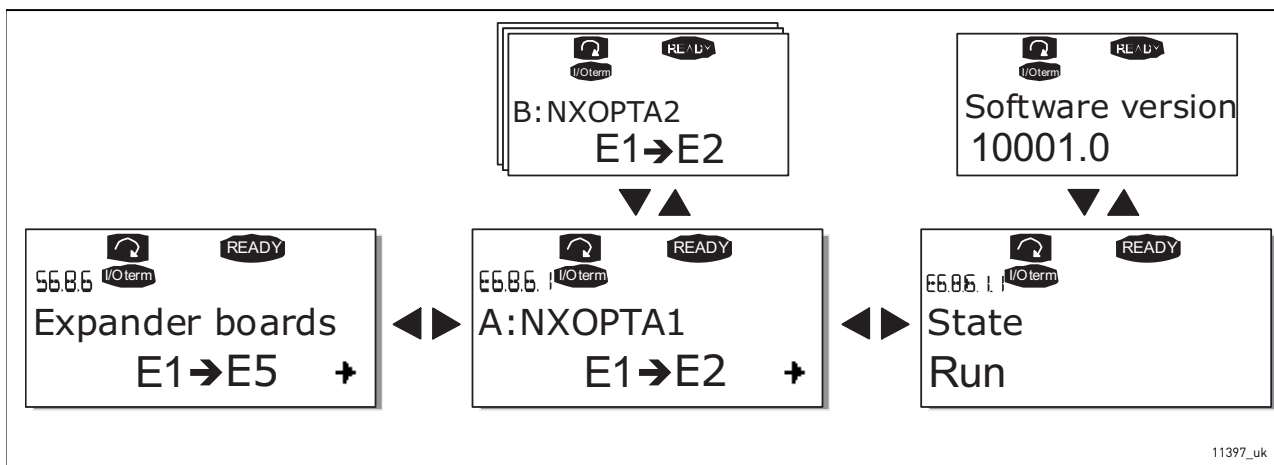

Figure 83. Expander board information menus

Debug menu (S6.8.7)

This menu is meant for advanced users and application designers. Contact factory for any assistance needed.

7.3.7 EXPANDER BOARD MENU (M7)

The Expander board menu makes it possible for the user 1) to see what expander boards are connected to the control board and 2) to reach and edit the parameters associated with the expander board.

Enter the following menu level (G#) with the Menu button right. At this level, you can browse through slots (see page 84) A to E with the Browser buttons to see what expander boards are connected. On the lowermost line of the display you also see the number of parameters associated with the board. You can view and edit the parameter values in the same way as described in Chapter 7.3.2. See Table 59 and Figure 84.

Expander board parameters

Table 59. Expander board parameters (board OPT-A1)

Code	Parameter	Min	Max	Default	Cust	Selections
P7.1.1.1	AI1 mode	1	5	3		1 = 0...20 mA 2 = 4...20 mA 3 = 0...10 V 4 = 2...10 V 5 = -10...+10 V
P7.1.1.2	AI2 mode	1	5	1		See P7.1.1.1
P7.1.1.3	AO1 mode	1	4	1		1 = 0...20 mA 2 = 4...20 mA 3 = 0...10 V 4 = 2...10 V

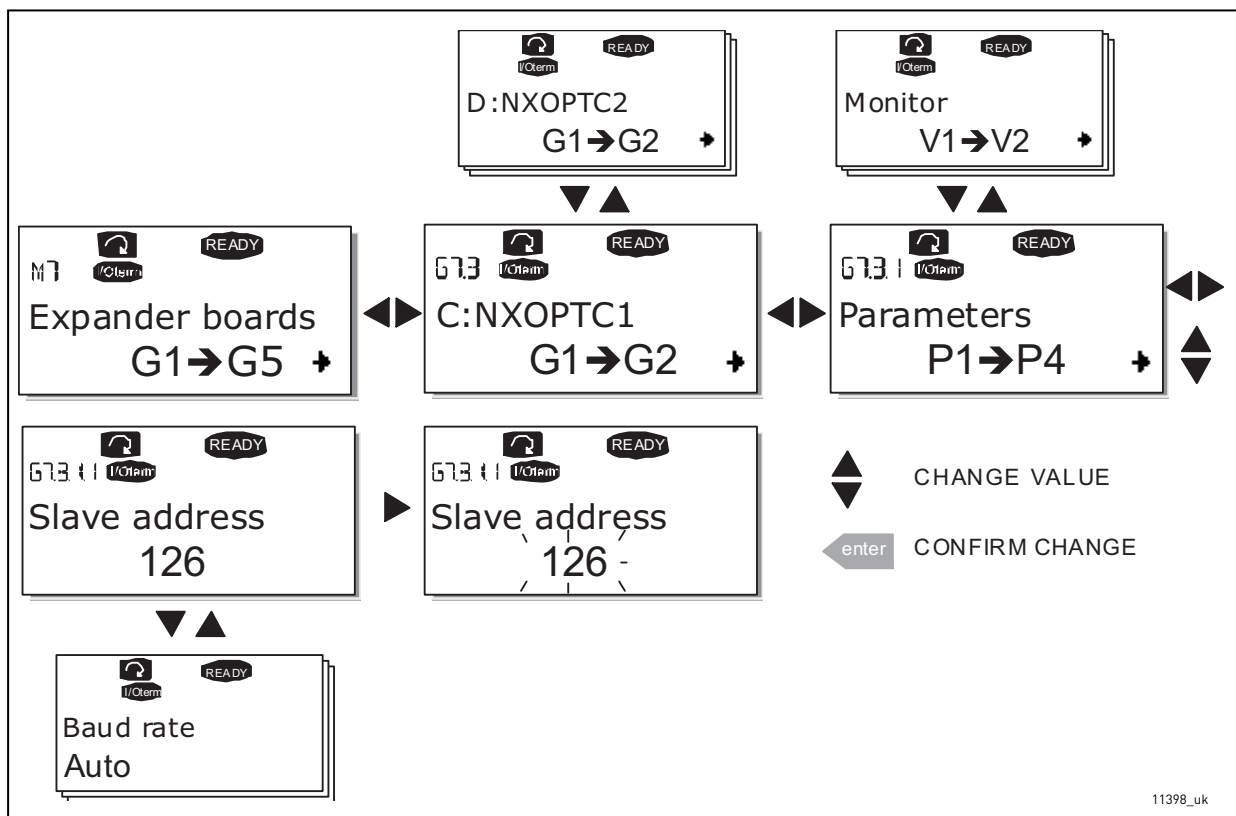

Figure 84. Expander board information menu

7.4 FURTHER KEYPAD FUNCTIONS

The VACON® NX control keypad embodies additional application-related functions. See VACON® NX Application Package for more information.

8. COMMISSIONING

8.1 SAFETY

Before commissioning, note the following directions and warnings:



Internal components and circuit boards of the AC drive are live when VACON® NX Liquid-Cooled drive is connected to mains potential. Coming into contact with this voltage is extremely dangerous and may cause death or severe injury.



The motor terminals U, V, W and the DC-link/brake resistor terminals B-, B+/R+, R- are live when VACON® NX Liquid-Cooled drive is connected to mains, even if the motor is not running.



The control I/O-terminals are isolated from the mains potential. However, the relay outputs and other I/O-terminals may have a dangerous control voltage present even when VACON® NX Liquid-Cooled drive is disconnected from mains.



Do not make any connections with the AC drive connected to the mains.



After having disconnected the AC drive from the mains, wait until the indicators on the keypad go out (if no keypad is attached see the indicator through the keypad base). Wait 5 more minutes before doing any work on VACON® NX Liquid-Cooled drive connections. Do not even open the cover before this time has expired.



Before connecting the NX Liquid-Cooled drive to mains, ensure the functionality of the coolant circulation and check the circulation for possible leaks.



Before connecting the drive to mains make sure that the switchgear enclosure door is closed.

8.2 COMMISSIONING OF THE AC DRIVE

1. Read carefully the safety instructions in Chapter 1 and follow them.
2. After the installation, pay attention:
 - that both the AC drive and the motor are grounded.
 - that the mains and motor cables comply with the requirements given in Chapter 6.1.1.
 - that the control cables are located as far as possible from the power cables and that the shields of the shielded cables are connected to protective earth . The wires may not touch the electrical components of the AC drive.
 - that the common inputs of digital input groups are connected to +24 V or ground of the I/O terminal or the external supply.
3. Check liquid cooling connections and system operation.
 - open the shut-off valves
 - check the quality and quantity of the cooling liquid (Chapter 5.2)
 - ensure the proper operation of liquid circulation system
4. Perform the cable and motor insulation checks, see Chapter 6.1.10.
5. Check the AC drive for condensation.
6. Check that all Start/Stop switches connected to the I/O terminals are in Stop-position.
7. Connect the AC drive to mains.
8. Set the parameters of group 1 (See VACON® All in One Application Manual) according to the requirements of your application. At least the following parameters should be set:
 - motor nominal voltage
 - motor nominal frequency
 - motor nominal speed
 - motor nominal current

You will find the values needed for the parameters on the motor rating plate.

9. Perform run test without motor

Perform either Test A or Test B:

A Controls from the I/O terminals:

- a) Turn the Start/Stop switch to ON position.
- b) Change the frequency reference (potentiometer).
- c) Check in the Monitoring menu (M1) that the value of Output frequency changes according to the change of frequency reference.
- d) Turn the Start/Stop switch to OFF position.

B Control from the control keypad:

- a) Change the control from the I/O terminals to the keypad as advised in Chapter 7.3.3.1.

- b) Push the Start button on the keypad.
 - c) Move over to the Keypad control menu (M3) and Keypad Reference submenu (Chapter 7.3.3.2) and change the frequency reference using the Browser buttons 
 - d) Check in the Monitoring menu (M1) that the value of Output frequency changes according to the change of frequency reference.
 - e) Push the Stop button on the keypad.
10. Run the start-up tests without the motor being connected to the process, if possible. If this is not possible, secure the safety of each test prior to running it. Inform your co-workers of the tests.
- a) Switch off the supply voltage and wait up until the drive has stopped as advised at Chapter 8.1, step 5.
 - b) Connect the motor cable to the motor and to the motor cable terminals of the AC drive.
 - c) See to that all Start/Stop switches are in Stop positions.
 - d) Switch the mains ON
 - e) Repeat test 9A or 9B.
11. Connect the motor to the process (if the startup test was run without the motor being connected).
- a) Before running the tests, make sure that this can be done safely.
 - b) Inform your co-workers of the tests.
 - c) Repeat test 9A or 9B.

9. FAULT TRACING

9.1 FAULT CODES

When a fault is detected by the AC drive control electronics, the drive is stopped and the symbol F together with the ordinal number of the fault, the fault code and a short fault description appear on the display. The fault can be reset with the Reset button on the control keypad or via the I/O terminal. The faults are stored in the Fault history menu (M5) which can be browsed. The different fault codes you will find in the table below.

The fault codes, their causes and correcting actions are presented in the table below. The shadowed faults are A faults only. The faults written in white on black background may appear as both A and F fault.

Table 60. Fault codes

Fault code	Fault	Possible cause	Correcting measures
1	Overcurrent	AC drive has detected too high a current (> 4*I _H) in the motor cable: <ul style="list-style-type: none"> - sudden heavy load increase - short circuit in motor cables - unsuitable motor Subcode in T.14: S1 = Hardware trip S3 = Current controller supervision	Check loading. Check motor. Check cables.
2	Overvoltage	The DC-link voltage has exceeded the limits defined in Table 9. <ul style="list-style-type: none"> - too short a deceleration time - high overvoltage spikes in supply Subcode in T.14: S1 = Hardware trip S2 = Overvoltage control supervision	Make the deceleration time longer. Use brake chopper or brake resistor (available for most chassis as options)
3	Earth fault	Current measurement has detected that the sum of motor phase current is not zero. <ul style="list-style-type: none"> - insulation failure in cables or motor 	Check motor cables and motor.
5	Charging switch	The charging switch is open, when the START command has been given. <ul style="list-style-type: none"> - faulty operation - component failure 	Reset the fault and restart. Should the fault re-occur, contact your local distributor.
6	Emergency stop	Stop signal has been given from the option board.	Check emergency stop circuit.

Table 60. Fault codes

Fault code	Fault	Possible cause	Correcting measures
7	Saturation trip	Various causes: <ul style="list-style-type: none"> - defective component - brake resistor short-circuit or overload 	Cannot be reset from the keypad. Switch off power. DO NOT RE-CONNECT POWER! Contact your local distributor. If this fault appears simultaneously with Fault 1, check motor cables and motor.
8	System fault	<ul style="list-style-type: none"> - component failure - faulty operation Note exceptional fault data record. Subcode in T.14: S1 = Feedback of motor voltage S2 = Reserved S3 = Reserved S4 = ASIC trip S5 = Disturbance in VaconBus S6 = Feedback of charging switch S7 = Charging switch S8 = No power to driver card S9 = Power unit communication (TX) S10 = Power unit communication (Trip) S11 = Power unit comm. (Measurement) S12 = Expander board (slot D or E) S30-S48 = OPT-AF board (slot B)	Reset the fault and restart. Should the fault re-occur, contact your local distributor.
9	Undervoltage	DC-link voltage is under the voltage limits defined in Table 9. <ul style="list-style-type: none"> - most probable cause: too low a supply voltage - AC drive internal fault Subcode in T.14: S1 = DC-link too low during run S2 = No data from power unit S3 = Undervoltage control supervision	In case of temporary supply voltage break reset the fault and restart the AC drive. Check the supply voltage. If it is adequate, an internal failure has occurred. Contact your local distributor.
10	Input line supervision	Input line phase is missing. Subcode in T.14: S1 = Phase supervision diode supply S2 = Phase supervision active front end	Check supply voltage, fuses and cable.
12	Brake chopper supervision	<ul style="list-style-type: none"> - no brake resistor installed - brake resistor is broken - brake chopper failure 	Check brake resistor and cabling. If ok, the chopper is faulty. Contact your local distributor.
13	Frequency converter undertemperature	Heatsink temperature is under -10 °C.	

Table 60. Fault codes

Fault code	Fault	Possible cause	Correcting measures
14	Frequency converter overtemperature	3) Heatsink temperature is over 70 °C. Overtemperature warning is issued when the heatsink temperature exceeds 65 °C. 4) Circuit board temperature is over 85 °C. Overtemperature warning is issued when the board temperature exceeds 75 °C. Subcodes: S1 = Overtemperature warning in unit, board or phases S2 = Overtemperature in power board S3 = Liquid flow S4 = Overtemperature on ASIC board or driver boards	<u>Cause 1):</u> Check that values for Ith (Chapter 4.2) are not exceeded. Check the correct coolant flow and temperature. Also check the circulation for possible leaks. Check the ambient temperature. Make sure that the switching frequency is not too high in relation to ambient temperature and motor load. <u>Cause 2):</u> Circulation of air in the drive is blocked. The cooling fans are defect.
15	Motor stalled	Motor stall protection has tripped.	Check motor and load.
16	Motor overtemperature	Motor overheating has been detected by AC drive motor temperature model. Motor is overloaded.	Decrease the motor load. If no motor overload exists, check the temperature model parameters.
17	Motor underload	Motor underload protection has tripped.	Check load.
18	Unbalance (Warning only)	Unbalance between power modules in paralleled units. Subcode in T.14: S1 = Current unbalance S2 = DC-Voltage unbalance	Should the fault re-occur, contact your local distributor.
22	EEPROM checksum fault	Subcodes: S1 = Firmware interface power down variable checksum error. S2 = Firmware interface variable checksum error. S3 = System power down variable checksum error S4 = System parameter checksum error S5 = Application-defined powerdown, variable checksum error. S6 = Application-defined powerdown, variable checksum. S10 = System parameter checksum error (fault history entries, device valid, system menu parameters).	Should the fault re-occur, contact your local distributor.
24	Counter fault	Values displayed on counters are incorrect.	Take a critical attitude towards values shown on counters.

Table 60. Fault codes

Fault code	Fault	Possible cause	Correcting measures
25	Microprocessor watchdog fault	<ul style="list-style-type: none"> - faulty operation - component failure Subcodes: S1 = CPU watchdog timer S2 = ASIC reset	Reset the fault and restart. Should the fault re-occur, contact your distributor.
26	Startup prevented	Start-up of the drive has been prevented. Subcodes: S1 = Prevention of accidental start-up. S2 = Appears if START command is ON, when returning to READY STATE after Safe Disable has been active. S30 = Appears if START command is ON after system software has been downloaded, after application has been downloaded or application has been changed.	Cancel prevention of start-up if this can be done safely.
29	Thermistor fault	The thermistor input of option board has detected increase of the motor temperature. Subcodes: S1 = Thermistor input activated on OPT-AF board S2 = Special application	Check motor cooling and loading. Check thermistor connection (If thermistor input of the option board is not in use it has to be short circuited).
30	Safe Disable warning	Safe disable inputs SD1 and SD2 are activated through the option board OPT-AF.	Contact your distributor.
31	IGBT temperature (hardware)	IGBT Inverter Bridge overtemperature protection has detected too high a short-term overload current.	Check loading. Check motor size.
34	CAN bus communication	Sent message not acknowledged.	Ensure that there is another device on the bus with the same configuration.
35	Application	Problem in application software.	Contact your distributor. If you are application programmer check the application program.
36	Control unit	VACON® NXS Control Unit can not control VACON® NXP Power Unit and vice versa.	Change control unit.
37	Device changed (same type)	Option board or power unit changed. New device of same type and rating. Subcodes: S1 = Control board S2 = Control unit S3 = Power board S4 = Power unit S5 = Adapter board and slot	Reset. Device is ready for use. Old parameter settings will be used.

Table 60. Fault codes

Fault code	Fault	Possible cause	Correcting measures
38	Device added (same type)	Option board added. Subcodes: S1 = Control board S4 = Control unit S5 = Adapter board and slot	Reset. Device is ready for use. Old board settings will be used.
39	Device removed	Option board removed.	Reset. Device no longer available.
40	Device unknown Unknown option board or drive.	Subcode in T.14: S1 = Unknown device S2 = Power1 not same type as Power2 S3 = NXS or NXP1 and star coupler S4 = Software and ctrl unit incompatible S5 = Old control board version	Contact your local distributor.
41	IGBT temperature	IGBT Inverter Bridge overtemperature protection has detected too high a short term overload current	Check loading. Check motor size.
42	Brake resistor overtemperature	Subcodes: S1 = Internal brake chopper overtemp. S2 = Brake resistance too high (BCU) S3 = Brake resistance too low (BCU) S4 = Brake resistance not detected (BCU) S5 = Brake resistance leakage (earth fault) (BCU)	Reset unit. Set the deceleration time longer and restart. Dimensioning of the brake chopper is not correct. Use external brake resistor.
43	Encoder fault	Problem detected in encoder signals. Sub code in T.14: S1 = Encoder 1 channel A is missing S2 = Encoder 1 channel B is missing S3 = Both enc. 1 channels are missing S4 = Encoder reversed S5 = Encoder board missing S6 = Serial communication fault S7 = Channel A/Channel B mismatch S8 = Resolver/Motor pole pair mismatch S9 = Missed start angle	Check encoder channel connections. Check the encoder board.
44	Device changed (different type)	Option board or power unit changed. New device of different type or different rating than the previous one. Subcodes: S1 = Control board S2 = Control unit S3 = Power board S4 = Power unit S5 = Adapter board and slot	Reset Set the option board parameters again if option board changed. Set AC drive parameters again if power unit changed.

Table 60. Fault codes

Fault code	Fault	Possible cause	Correcting measures
45	Device added (different type)	Option board of different type added. Subcodes: S1 = Control board S2 = Control unit S3 = Power board S4 = Power unit S5 = Adapter board and slot	Reset Set the option board parameters again.
49	Div by zero in application	A division by zero has occurred in the application program.	Contact your distributor. If you are application programmer check the application program.
50	Analogue input lin < 4mA (sel. signal range 4 to 20 mA)	Current at the analogue input is < 4mA. - control cable is broken or loose - signal source has failed	Check the current loop circuitry.
51	External fault	Digital input fault.	
52	Keypad communication fault	Keypad communication fault The connection between the control keypad and the AC drive is broken.	Check keypad connection and possible keypad cable.
53	Fieldbus fault	The data connection between the fieldbus Master and the fieldbus board is broken.	Check installation. If installation is correct contact the nearest distributor.
54	Slot fault	Defective option board or slot.	Check board and slot. Contact the nearest distributor.
55	Actual value supervision		
56	PT100 board temp. fault	Temperature limit values set for the PT100 board parameters have been exceeded.	Find the cause of temperature rise.
57	Identification	Identification run has failed.	Run command was removed before completion of identification run. Motor is not connected to AC drive. There is load on motor shaft.
58	Brake	Actual status of the brake is different from the control signal.	Check mechanical brake state and connections.
59	Follower communication	SystemBus or CAN communication is broken between Master and Follower.	Check option board parameters. Check optical fibre cable or CAN cable.
60	Cooling	Coolant circulation on liquid-cooled drive has failed.	Check reason for the failure on external system.

Table 60. Fault codes

Fault code	Fault	Possible cause	Correcting measures
61	Speed error	Motor speed is unequal to reference.	Check encoder connection. PMS motor has exceeded the pull out torque.
62	Run disable	Run enable signal is low.	Check reason for Run enable signal.
63	Emergency stop	Command for emergency stop received from digital input or fieldbus.	New run command is accepted after reset.
64	Input switch open	Drive input switch is open.	Check the main power switch of the drive.

9.2 LOAD TEST WITH MOTOR

1. Connect the motor cables and check the right phase order. Also check that the motor rotates freely.
2. Check liquid cooling system operation.
3. Turn on the supply voltage and ensure that all input phases are connected to the unit.
4. Check DC link voltage by measuring with multimeter and compare the value to the one on monitoring page V1.8.
5. Select the application of your choice and set the needed parameters (see Start-up Quick Guide, step 8 on page 4).
6. Start the operation with lower Current Limit value and long Acceleration/Deceleration times.
7. If Closed Loop control mode is used, check direction of encoder and make necessary Closed Loop parameter settings. Check the correct operation of the encoder by running the system in open loop and check the signals in the expander board menu.
8. Run the motor without load between minimum and maximum frequencies and check the unit output current with a current clamp. Compare the value to the one on monitoring page V1.4.
9. Load the motor to nominal value if possible and repeat the current measurement. Follow the Unit Temperature value on page V1.9.

9.3 DC LINK TEST (WITHOUT MOTOR)

NOTE! There will be dangerous voltages present during this test!

1. Read carefully the safety instructions in Chapter 1 and follow them.
2. Connect a variable DC power supply to DC+ and DC- terminals. Make sure that all polarities are correct.
3. Slowly charge up the DC link to nominal voltage. Allow the system to remain at this level for at least one minute and check current.
4. If possible, continue increasing the DC link voltage up to the trip limit. Fault F2 (see Chapter 9) should occur at 911 VDC (NX_5, 400...500-volt units), at 1200 VDC (NX_6, 525...690-volt units) and 1300 VDC (NX_8, 525...690-volt units). Do not increase the voltage over the trip limit.
5. Bring the power supply voltage back to zero. Allow sufficient time for the capacitors to discharge.
6. Check the DC bus voltage with a multimeter. When you read zero volts disconnect the power supply and reconnect all wires to the phase module.
7. If the phase module has been de-energized for an extended period of time (six months or longer) allow this voltage to remain for a minimum of 30 minutes – even 4 hours if time permits.

Through the above test procedure, two things are achieved: 1) It allows the caps to partially reform due to storage and shipping; 2) It allows any device failures to evidence themselves with a low power failure.

10. ACTIVE FRONT END (NXA)

10.1 INTRODUCTION

The VACON® NX Active Front End is used to transfer power between the AC input and intermediate DC circuit. The VACON® NX Active Front End has a two-way function. This means that when power is transferred from the AC input to the intermediate DC circuit, the VACON® NX Active Front End rectifies the alternating current and voltage. When power is transferred from the intermediate DC circuit to the AC input, the VACON® NX Active Front End inverts the direct current and voltage.

The Active Front End configurations consist of the unit itself, LCL filter, pre-charging circuit, control unit, AC fuses, main contactor / circuit breaker and DC fuses which you need to take into account when planning the switchgear configuration, see Figure 85.

10.2 DIAGRAMS

10.2.1 ACTIVE FRONT END UNIT BLOCK DIAGRAM

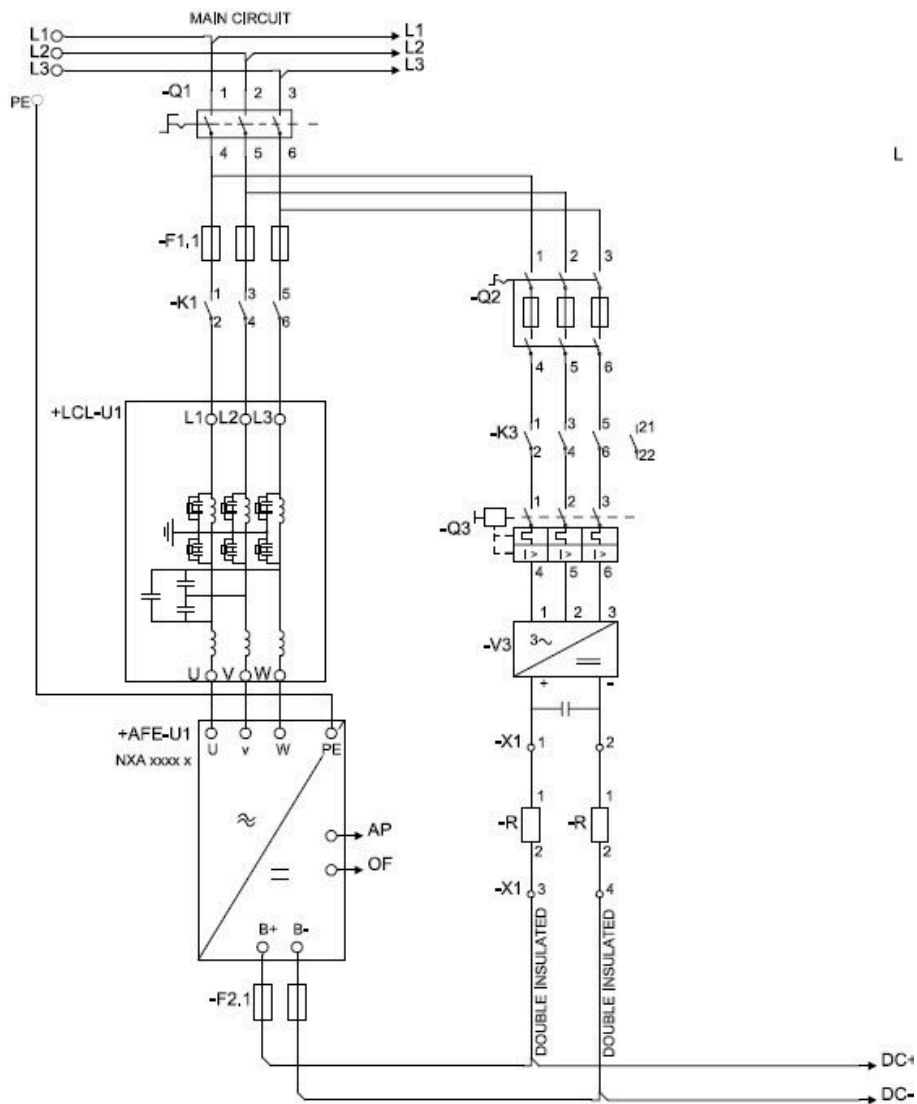

3073_uk

Figure 85. Active front end configuration

10.3 TYPE DESIGNATION CODE

In Vacon type designation code, the Active Front Unit is characterized by the characters **NXA** and number **2**, for example:

NXA	0300	5	A	0	T	0	2WF	A1A2000000
------------	------	---	---	---	---	---	------------	------------

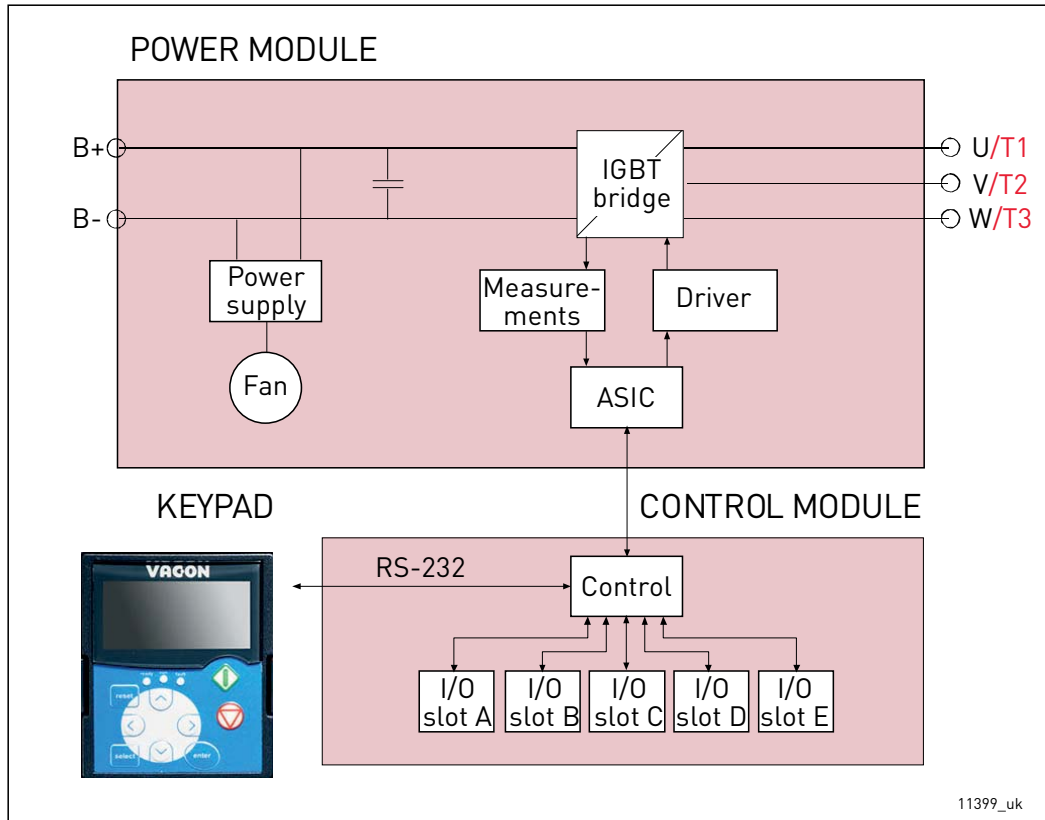

Figure 86. Active front end block diagram

10.4 ACTIVE FRONT END UNIT TECHNICAL DATA

The technical data for the active front end unit, see table below.

*) NX_8 AC drives only available as Ch6x AFE/BCU/INU units.

Table 61. Technical data

Mains connection	Input voltage U_{in}	NX_5: 400...500 VAC (-10%...+10%); 465...800 VDC (-0%...+0%) NX_6: 525...690 VAC (-10%...+10%); 640...1100 VDC (-0%...+0%) NX_8: 525...690 VAC (-10%...+10%); 640...1200 VDC (-0%...+0%)*)	
	Input frequency	45...66 Hz	
	Connection to mains	Once per minute or less	
	DC bank capacitance	Voltage class 500 V:	Ch3 (16-31A units): 410 μ F Ch3 (38-61A units): 600 μ F CH4: 2400 μ F CH5: 7200 μ F CH61: 10800 μ F CH62/CH72: 10800 μ F CH63: 21600 μ F CH64/CH74: 32400 μ F 2*CH64/2*CH74: 64800 μ F
	Voltage class 690 V:	CH61: 4800 μ F CH62/CH72: 4800 μ F CH63: 9600 μ F CH64/CH74: 14400 μ F 2*CH64/2*CH74: 28800 μ F	
Supply network	Networks	TN, TT, IT	
	Short circuit current	Maximum short circuit current has to be < 100 kA.	
	Rated apparent power	The rated apparent power of the supply network including generators and/or transformers should be greater than 50% of the total rated apparent power of the Active Front End units which are connected to the network.	
DC output connection	Voltage	1.35 x U_{in} x 1.1 (default DC link voltage boosting is 110%)	
	Continuous output current	Rated current at nominal inflow cooling water temperature according to dimensioning charts.	
Control characteristics	Control method	Open Loop Vector Control	
	Switching frequency	NXA: Factory setting 3.6 kHz	

Table 61. Technical data

Ambient conditions	Ambient operating temperature	-10 °C (no frost)...+50 °C (at I_{th}) The VACON® NX Liquid-Cooled drives must be used in an heated indoor controlled environment.
	Installation temperature	0...+70 °C
	Storage temperature	-40 °C...+70 °C; No liquid in heatsink under 0 °C
	Relative humidity	5 to 96% RH, non-condensing, no dripping water
	Air quality: <ul style="list-style-type: none"> chemical vapours mechanical particles 	IEC 60721-3-3, unit in operation, class 3C2 IEC 60721-3-3, unit in operation, class 3S2 (no conductive dust allowed) No corrosive gases
	Altitude	NX_5: (380...500 V): max. 3000 m (in case network is not corner grounded) NX_6/NX_8: max. 2000 m. For further requirements, contact factory 100-% load capacity (no derating) up to 1,000 m; above 1,000 m derating of maximum ambient operating temperature by 0.5 °C per each 100 m is required.
	Vibration EN 50178/EN 60068-2-6	5...150 Hz Displacement amplitude 0.25 mm (peak) at 3...31 Hz Max acceleration amplitude 1 G at 31...150 Hz
	Shock EN 50178, EN 60068-2-27	UPS Drop Test (for applicable UPS weights) Storage and shipping: max 15 G, 11 ms (in package)
	Enclosure class	IP00/Open Frame standard in entire kW/HP range
Pollution degree	PD2	
EMC	Immunity	Fulfils IEC/EN 61800-3 EMC immunity requirements.
	Emissions	EMC level N for TN/TT networks EMC level T for IT networks
Safety		IEC/EN 61800-5-1 (2007), CE, UL, cUL, GOST R, (see unit nameplate for more detailed approvals) IEC 60664-1 and UL840 in overvoltage category III.
	Safe Torque Off (STO) board	The drive is equipped with VACON® OPTAF board for prevention of torque on motor shaft . Standards: prEN ISO 13849-1 (2004), EN ISO 13849-2 (2003), EN 60079-14 (1997), EN 954-1 (1996), cat. 3 (hardware disable); IEC 61508-3(2001), prEN 50495 (2006). See VACON® NX OPTAF STO Board User Manual for detailed information.

Table 61. Technical data

Control connections (apply to boards OPT-A1, OPT-A2 and OPT-A3)	Analogue input voltage	0...+10 V, $R_i = 200 \text{ k}\Omega$, (-10 V...+10 V joystick control) Resolution 0.1%, accuracy $\pm 1\%$
	Analogue input current	0(4)...20 mA, $R_i = 250 \text{ W}$ differential
	Digital inputs (6)	Positive or negative logic; 18...24 VDC
	Auxiliary voltage	+24 V, $\pm 10\%$, max volt. ripple < 100 mVrms; max. 250 mA Dimensioning: max. 1000 mA/control box 1A external fuse required (no internal short-circuit protection on the control board)
	Output reference voltage	+10 V, +3%, max. load 10 mA
	Analogue output	0(4)...20 mA; R_L max. 500 Ω ; Resolution 10 bit; Accuracy $\pm 2\%$
	Digital outputs	Open collector output, 50 mA/48 V
	Relay outputs	2 programmable change-over relay outputs Switching capacity: 24 VDC/8 A, 250 VAC/8 A, 125 VDC/0.4 A Min. switching load: 5 V/10 mA
Protections	Overvoltage trip limit	NX_5: 911 VDC NX_6: (CH61, CH62, CH63 & CH64): 1258 VDC NX_8: 1300 VDC
	Undervoltage trip limit	NX_5: 333 VDC; NX_6: 461 VDC; NX_8: 461 V (all VDC)
	Earth fault protection	In case of earth fault in motor or motor cable, only the AC drive is protected.
	Mains supervision	Trips if any of the input phases is missing (AC drives only).
	Input phase monitoring	Trips if any of the output phases is missing.
	Unit overtemperature protection	Alarm limit: 65 °C (heatsink); 75 °C (circuit boards). Trip limit: 70 °C (heatsink); 85 °C (circuit boards).
	Overcurrent protection	Yes
	Unit overheat protection	Yes
	Short-circuit protection of +24 V and +10 V reference voltages	Yes

Table 61. Technical data

Liquid cooling	Allowed cooling agents	Drinking water (see specification on page 49) Water-glycol mixture See derating specifications, Chapter 5.3.
	Volume	See Table 19.
	Temperature of cooling agent	0...35 °C input (I_{th}); 35...55 °C: derating required, see Chapter 5.3. Max. temperature rise during circulation max. 5 °C No condensation allowed. See Chapter 5.2.1.
	Cooling agent flow rates	See Table 15.
	System max. working pressure	6 bar
	System max. peak pressure	30 bar
	Pressure loss (at nom. flow)	Varies according to size. See Table 17.

10.5 POWER RATINGS

Table 62. Power ratings of VACON® NX Liquid-Cooled AFE unit, supply voltage 400-500 VAC

VACON NX Liquid-Cooled Front End; DC Bus voltage 465–800 VDC									
Active front-end type	AC Current			DC power				Power loss c/a/T*) [kW]	Chassis
	Thermal I_{th} [A]	Rated I_L [A]	Rated I_H [A]	400 VAC mains I_{th} [kW]	500 VAC mains I_{th} [kW]	400 VAC mains I_L [kW]	500 VAC mains I_L [kW]		
0168_5	168	153	112	113	142	103	129	2.5/0.3/2.8	CH5
0205_5	205	186	137	138	173	125	157	3.0/0.4/3.4	CH5
0261_5	261	237	174	176	220	160	200	4.0/0.4/4.4	CH5
0300_5	300	273	200	202	253	184	230	4.5/0.4/4.9	CH61
0385_5	385	350	257	259	324	236	295	5.5/0.5/6.0	CH61
0460_5	460	418	307	310	388	282	352	5.5/0.5/6.0	CH62
0520_5	520	473	347	350	438	319	398	6.5/0.5/7.0	CH62
0590_5	590	536	393	398	497	361	452	7.5/0.6/8.1	CH62
0650_5	650	591	433	438	548	398	498	8.5/0.6/9.1	CH62
0730_5	730	664	487	492	615	448	559	10.0/0.7/10.7	CH62
0820_5	820	745	547	553	691	502	628	10.0/0.7/10.7	CH63
0920_5	920	836	613	620	775	563	704	12.4/0.8/12.4	CH63
1030_5	1030	936	687	694	868	631	789	13.5/0.9/14.4	CH63
1150_5	1150	1045	767	775	969	704	880	16.0/1.0/17.0	CH63
1370_5	1370	1245	913	923	1154	839	1049	15.5/1.0/16.5	CH64
1640_5	1640	1491	1093	1105	1382	1005	1256	19.5/1.2/20.7	CH64
2060_5	2060	1873	1373	1388	1736	1262	1578	26.5/1.5/28.0	CH64
2300_5	2300	2091	1533	1550	1938	1409	1762	29.6/1.7/31.3	CH64

*) C = power loss into coolant, A = power loss into air, T = total power loss.

The enclosure class for all VACON® NX Liquid-Cooled AC drives is IP00.

I_{th} = Thermal maximum continuous RMS current. Dimensioning can be done according to this current if the process does not require any overloadability or the process does not include any load variation.

I_L = Low overloadability current. Allows +10% load variation. 10% exceeding can be continuous.

I_H = High overloadability current. Allows +50% load variation. 50% exceeding can be continuous.

All values with $\cos\phi = 0.99$ and efficiency = 97.5%.

*) c = power loss into coolant; a = power loss into air; T = total power loss.

All power losses obtained using max. supply voltage, I_{th} and switching frequency of 3.6 kHz. All power losses are worst case losses.

Table 63. Power ratings of VACON® NX Liquid-Cooled AFE unit, supply voltage 525-690 VAC

VACON NX Liquid-Cooled Front End; DC Bus voltage 640–1100 VDC ***)									
Active front-end type	AC Current			DC power				Power loss c/a/T*) [kW]	Chassis
	Thermal I_{th} [A]	Rated I_L [A]	Rated I_H [A]	525 VAC mains I_{th} [kW]	690 VAC mains I_{th} [kW]	525 VAC mains I_L [kW]	690 VAC mains I_L [kW]		
0170_6	170	155	113	150	198	137	180	3.6/0.2/3.8	CH61
0208_6	208	189	139	184	242	167	220	4.3/0.3/4.6	CH61
0261_6	261	237	174	231	303	210	276	5.4/0.3/5.7	CH61
0325_6	325	295	217	287	378	261	343	6.5/0.3/6.8	CH61
0385_6	385	350	257	341	448	310	407	7.5/0.4/7.9	CH62
0416_6	416	378	277	368	484	334	439	8.0/0.4/8.4	CH62
0460_6	460	418	307	407	535	370	486	8.7/0.4/9.1	CH62
0502_6	502	456	335	444	584	403	530	9.8/0.5/10.3	CH62
0590_6	590	536	393	522	686	474	623	10.9/0.6/11.5	CH63
0650_6	650	591	433	575	756	523	687	12.4/0.7/13.1	CH63
0750_6	750	682	500	663	872	603	793	14.4/0.8/15.2	CH63
0820_6	820	745	547	725	953	659	866	15.4/0.8/16.2	CH64
0920_6	920	836	613	814	1070	740	972	17.2/0.9/18.1	CH64
1030_6	1030	936	687	911	1197	828	1088	19.0/1.0/20.0	CH64
1180_6	1180	1073	787	1044	1372	949	1247	21.0/1.1/22.1	CH64
1300_6	1300	1182	867	1150	1511	1046	1374	24.0/1.3/25.3	CH64
1500_6	1500	1364	1000	1327	1744	1207	1586	28.0/1.5/29.5	CH64
1700_6	1700	1545	1133	1504	1976	1367	1796	32.1/1.7/33.8	CH64

*) C = power loss into coolant, A = power loss into air, T = total power loss.

The enclosure class for all VACON® NX Liquid-Cooled AC drives is IP00.

***) Mains voltage 640-1200 VDC for NX_8 inverter units.

I_{th} = Thermal maximum continuous RMS current. Dimensioning can be done according to this current if the process does not require any overloadability or the process does not include any load variation.

I_L = Low overloadability current. Allows +10% load variation. 10% exceeding can be continuous.

I_H = High overloadability current. Allows +50% load variation. 50% exceeding can be continuous.

All values with $\cos\phi = 0.99$ and efficiency = 97.5%.

*) c = power loss into coolant; a = power loss into air; T = total power loss.

All power losses obtained using max. supply voltage, I_{th} and switching frequency of 3.6 kHz. All power losses are worst case losses.

10.6 LIQUID-COOLED RLC FILTERS

10.6.1 INTRODUCTION

VACON® Liquid-Cooled AFE units can be used with either Liquid Cooled or Air Cooled LCL filters. The standard Liquid Cooled LCL filters are named RLC filter. The RLC filter type codes can be seen from Table 62. The RLC filters are not included in the standard delivery of the AFE units and therefore they need to be ordered separately. More information about Air Cooled LCL filters can be found from UD01190B, VACON® NX Active Front End User’s Manual, FI9-13.

10.6.2 WIRING DIAGRAMS

The RLC filter contains a 3-phase chokes (L_{net}) on the mains side, capacitors bank (C_{bank}) and 3 pcs of 1-phase choke (L_{drive}) on the AFE side, Figure 87. The RLC also includes capacitors connected against ground potential. There are resistors connected across the capacitors for discharging them when the LCL filter is disconnected from the input power. The discharging resistors are 10 MΩ, 500 V and 0.5 W.

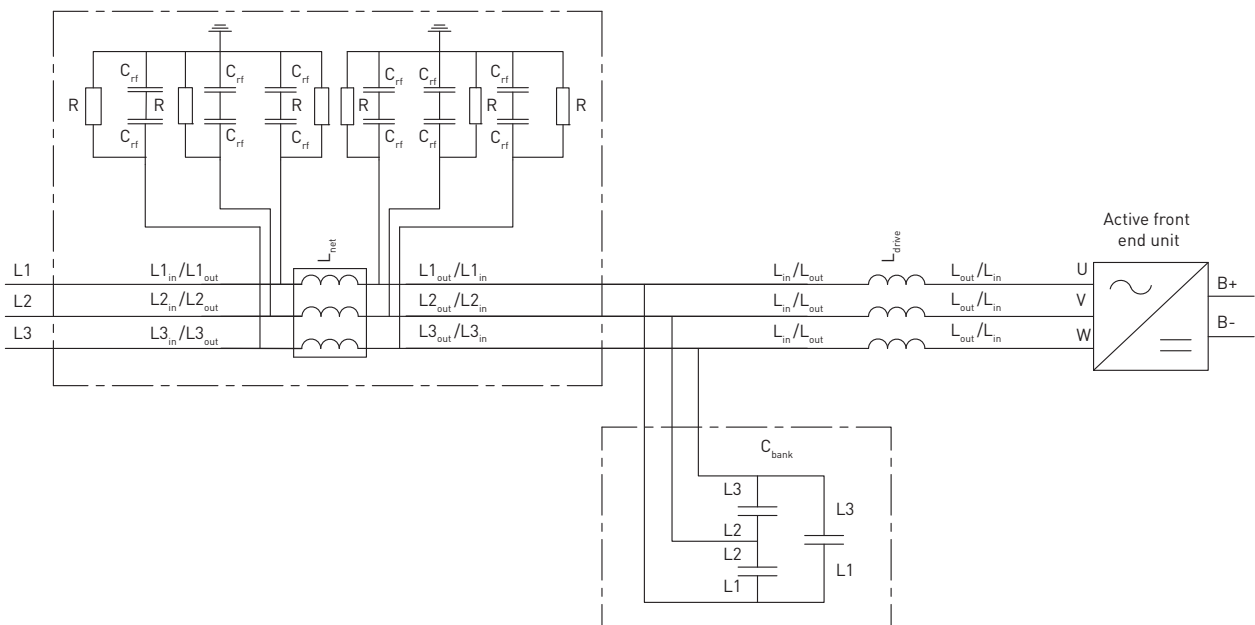

3071_uk

Figure 87. VACON® RLC filter wiring diagram

10.6.3 POWER RATING AND DIMENSIONS

Table 64. VACON® RLC ratings, drive suitable and dimensions

VACON NX Liquid-Cooled regenerative line filters - IP00							
LCL filter type	Thermal current I_{th} [A]	Power loss $c/a/T^*$ [kW]	Suitability [Drive/voltage:(current)]	Dimensions L_{net} , 1pcs $W \times H \times D$ [mm]	Dimensions L_{drive} , 1pcs (total 3pcs), $W \times H \times D$ [mm]	Dimensions C_{bank} , 1pcs $W \times H \times D$ [mm]	Total Weight [kg]
RLC-0385-6-0	385	2.6/0.8/3.4	CH62/690 VAC: 325 A & 385 A	580 x 450 x 385	410 x 415 x 385	360 x 265 x 150	458
RLC-0520-6-0	520	2.65/0.65/3.3	CH62/500-690 VAC	580 x 450 x 385	410 x 415 x 385	360 x 265 x 150	481
RLC-0750-6-0	750	3.7/1/4.7	CH62/500 VAC, CH63/690 VAC	580 x 450 x 385	410 x 450 x 385	360 x 275 x 335	508
RLC-0920-6-0	920	4.5/1.4/5.9	CH63/500 VAC, CH64/690 VAC	580 x 500 x 390	410 x 500 x 400	360 x 275 x 335	577
RLC-1180-6-0	1180	6.35/1.95/8.3	CH63/500 VAC, CH64/690 VAC	585 x 545 x 385	410 x 545 x 385	350 x 290 x 460	625
RLC-1640-6-0	1640	8.2/2.8/11	CH64/500-690 VAC	585 x 645 x 385	420 x 645 x 385	350 x 290 x 460	736
RLC-2300-5-0	2300	9.5/2.9/12.4	CH64/500 VAC: 2060 A & 2300 A	585 x 820 x 370	410 x 820 x 380	580 x 290 x 405	896

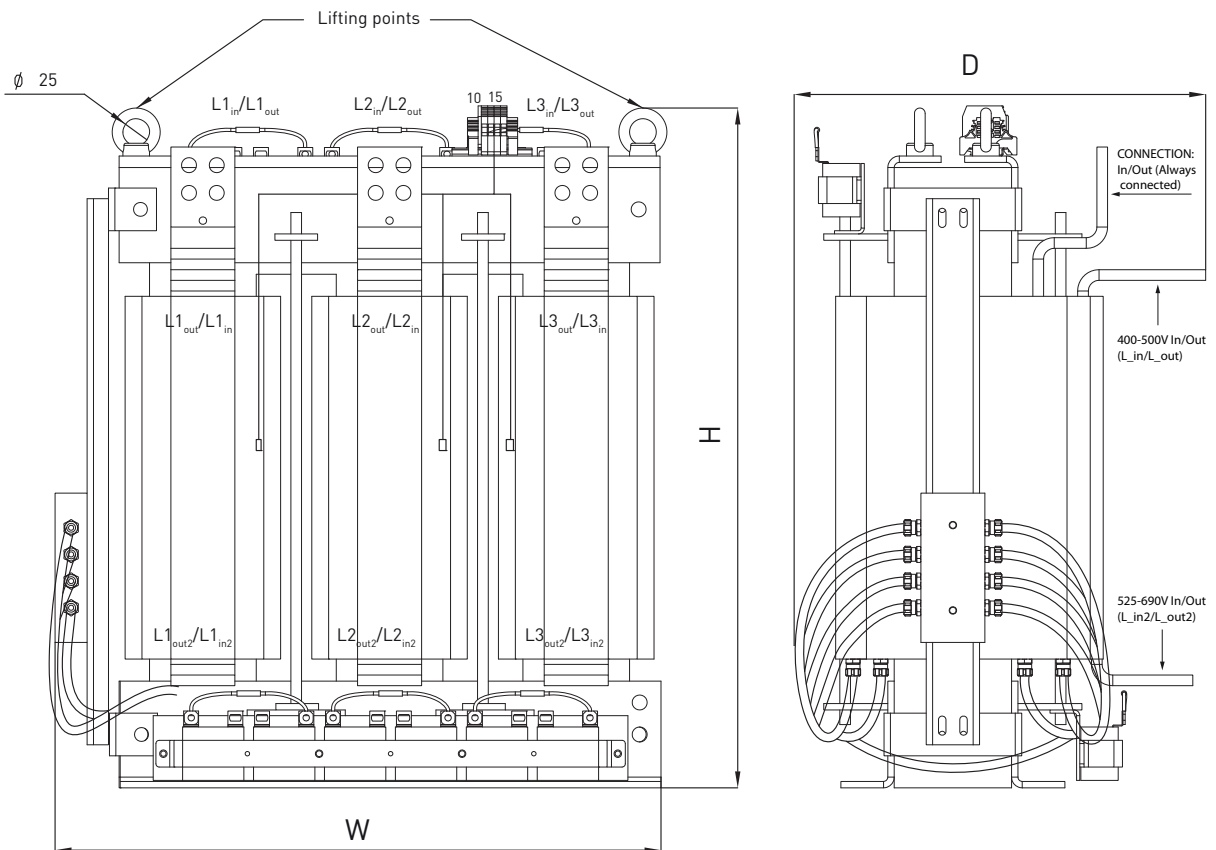

3069A_uk

Figure 88. Example of L_{net} choke of a VACON® RLC filter

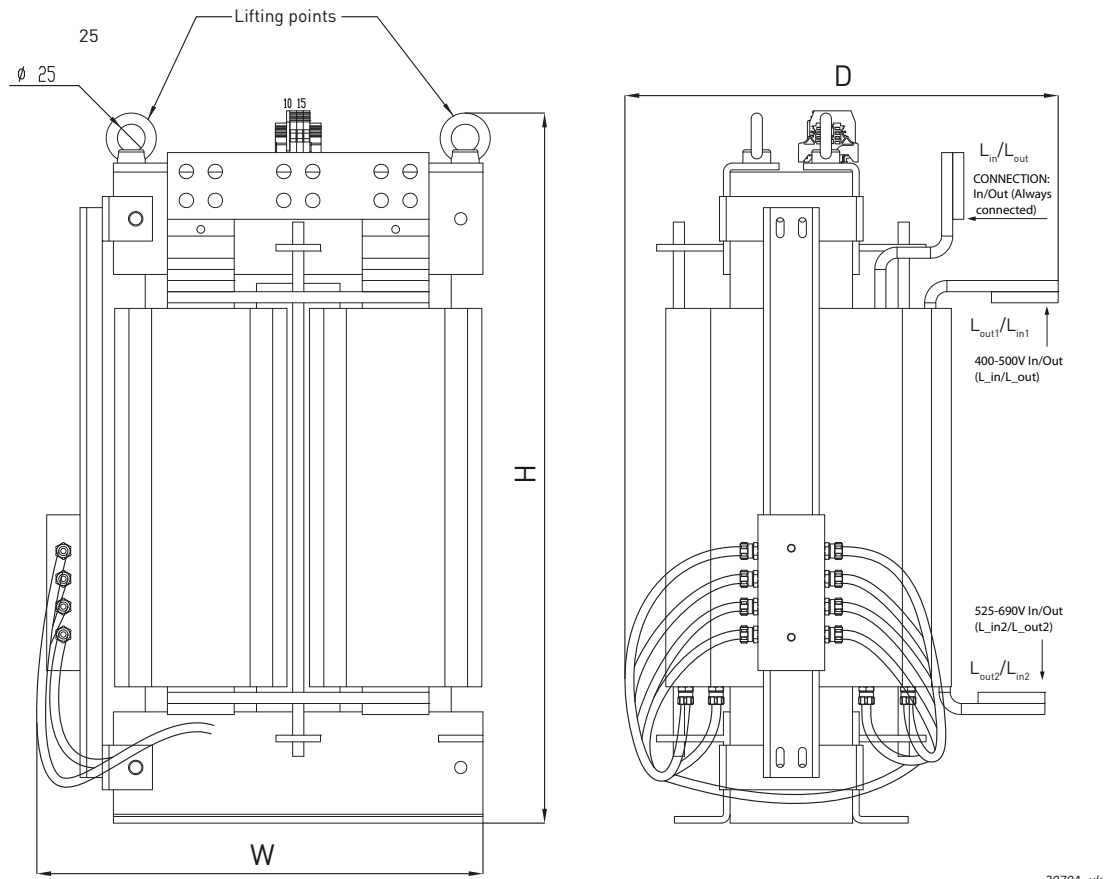

3070A_uk

Figure 89. Example of L_{afe} choke of a VACON[®] RLC filter

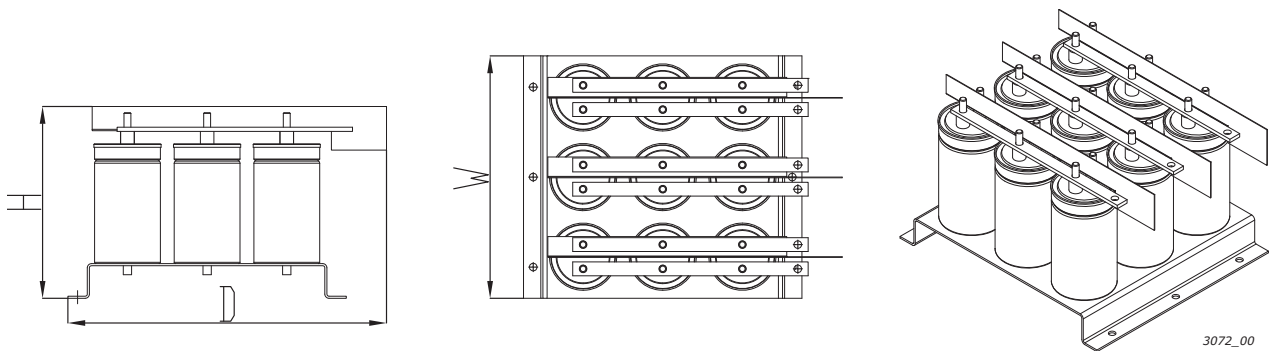

3072_00

Figure 90. Example of capacitor bank (C_{bank}) of a VACON[®] RLC filter

10.6.4 TECHNICAL DATA

Table 65. VACON® RLC technical data

AC connections	Voltage U_{in}	Same as the NXA unit.
	Frequency f_{in}	50 or 60 Hz + 2%.
	Continuous output current	See current rating of filter.
	Switching frequency	3.6 kHz
Ambient conditions	Ambient temperature during operation	-10...+50 °C
	Installation temperature	0...+70 °C
	Storage temperature	-40...+70 °C, no liquid in filter under 0 °C.
	Relative humidity	Same as the NXA unit.
	Enclosure class	IP00
Liquid cooling	Allowed cooling agents	Drinking water, demineralized water or a mixture of water and glycol. (To avoid electromechanical corrosion it is necessary to add an inhibitor.)
	Temperature of cooling agent	0...+60 °C
	Cooling agent flow rate	8l/min for one choke, total 32 l/min (for 1pcs L_{net} choke and 3pcs L_{drive} chokes).
	System max working pressure	6 bar
	Coolant connection	G3/8" female thread x 2 pcs. (1pcs inlet / 1pcs outlet)
Protection	Over-temperature monitoring	Thermal relay at each winding of the chokes. Thermal relays connected in series between terminals 10 and 15. Relay contact type: normally closed. Switching temperature: 150 °C.

10.6.5 REMOVING DISCHARGING RESISTORS

If the filter is used in a network fitted with an earth fault protection relay, the discharging resistors should be removed. If the discharging resistors are not removed, the earth fault monitoring device might indicate a very low leakage resistance. **The resistors must be connected so that the capacitors are discharged when disconnecting from the input power.** The wiring diagram of an alternative discharging circuit can be seen in Figure 91. The discharging resistors should be 10 k Ω , 500 V and 2 W. Failure to ensure the discharging of capacitors take a very long time to discharge.

Figure 92 and Figure 93 have a blue marking on the lead that has to be removed from each capacitors if the discharge resistor is not to be used.

WARNING! If you do not allow a total discharge of the system before starting the modification, it is likely that you will get an electricshock in spite of the fact the system is disconnected from the power supply.

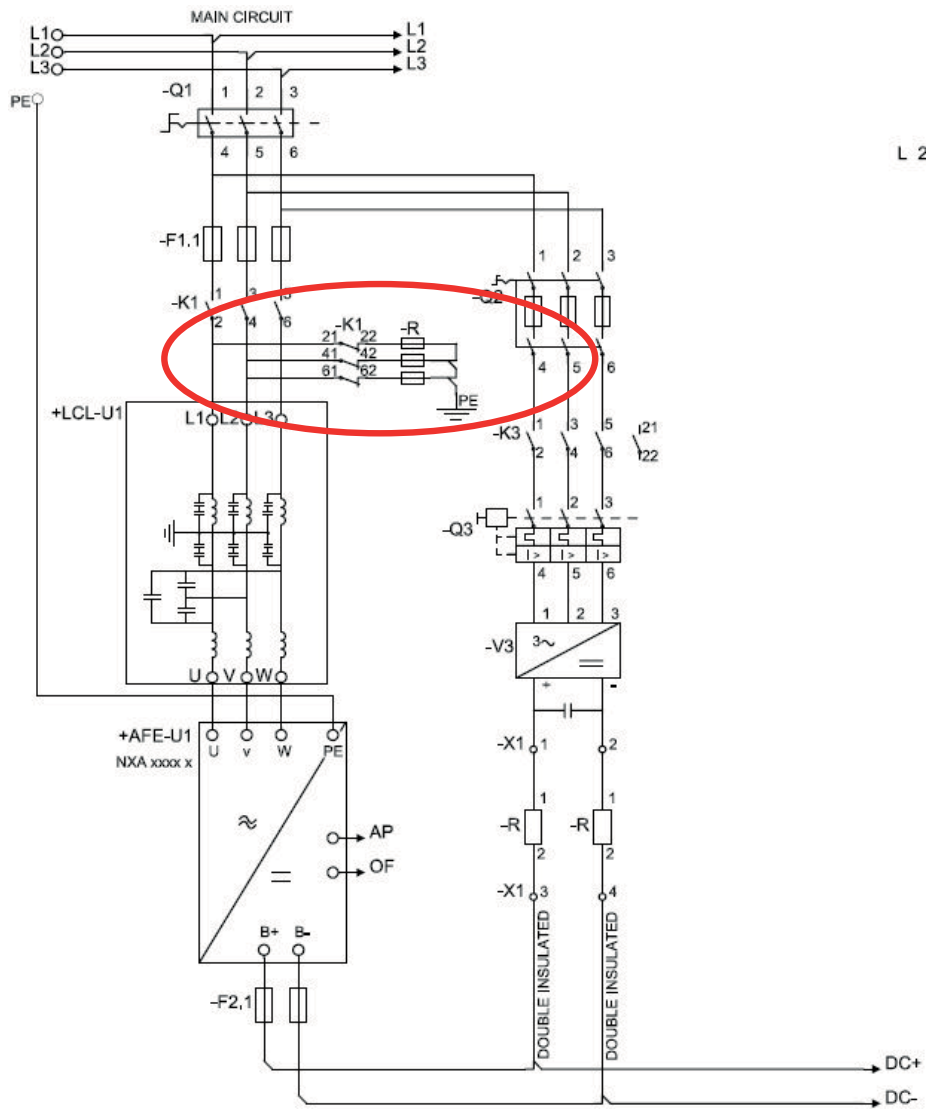

3074_uk

Figure 91. Wiring diagram of the alternative discharging circuit configuration

10.6.6 REMOVING HF CAPACITORS

If a PWM modulated rectifier from another manufacturer is connected to the same input transformer, the capacitors must be removed! Otherwise the capacitors must not be removed.

Figure 92 and Figure 93 have a red marking on the lead that has to be removed from each capacitor if the interference suppression capacitors are not to be used. Removing the lead disconnects the capacitors from ground potential.

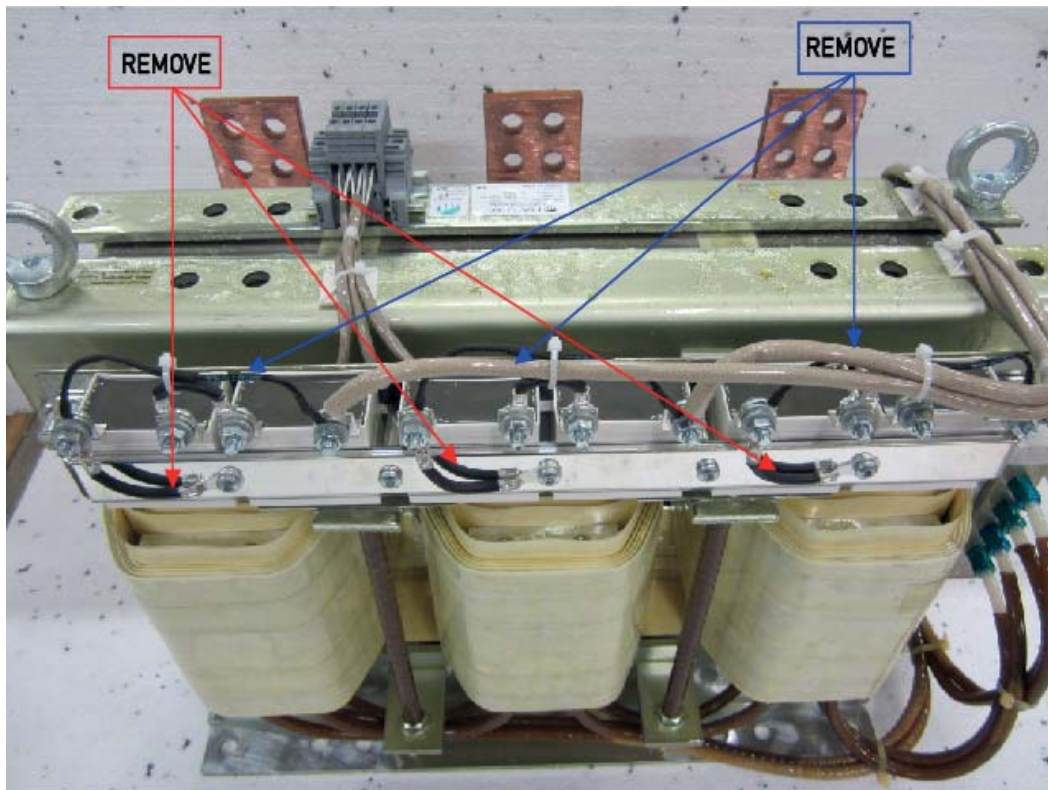

11400_uk

Figure 92. HF capacitors in RLC filters

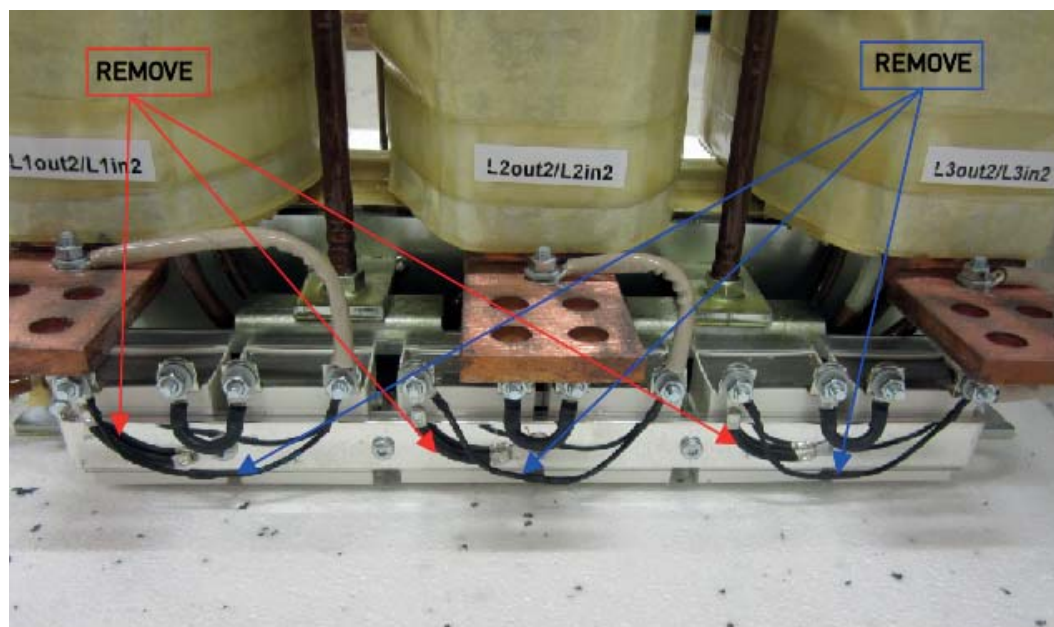

11401_uk

Figure 93. HF capacitors in RLC filters

10.7 ACTIVE FRONT END - FUSE SELECTION

AC fuses are used to protect the input network in case the Active Front End unit or the LCL filter is faulty. DC fuses are used to protect the Active Front End unit and the LCL filter in case there is a short circuit in the DC buses. If DC fuses are not used, short-circuit in the DC buses will cause a loading of the Active Front End unit. Vacon Ltd will not assume any responsibility for damages caused by insufficient protection. **The warranty becomes void if the drive is not equipped with appropriate fuses.**

Fuse information

The values in tables are based on max ambient temperature of +50 °C.

Fuse sizes can differ in the same chassis. Make sure that the Isc of the supply transformer is high enough to burn fuses fast enough.

Check the current rating of the fuse bases according to the input current of the drive.

The physical size of the fuse is chosen on the basis of the fuse current: Current < 250 amps (size 1 fuse), current > 250 amps (size 3 fuse).

The aR fuses are thermally rated into switch fuse in 50 degree ambient temperature.

The required AC fuse selection for the active front end unit can be found from Table 66 and Table 67. The required DC fuse selection for the active front end unit can be found from Table 38 and Table 39.

10.7.1 FUSE SIZES, ACTIVE FRONT END UNITS (AC SUPPLY)

Table 66. Fuse sizes for VACON® NX AFE units (380–500V)

Chassis	Type	I _{th} [A]	Fuse size	DIN43620	'TTF' threaded end	'TTF' threaded end	Qty. of fuses / drive 3~
				aR fuse part nr.	aR fuse part nr.	aR fuse part nr.	
CH3	0016	16	DIN000	NH000UD69V40PV	PC30UD69V50TF	-	3
CH3	0022	22	DIN000	NH000UD69V40PV	PC30UD69V50TF	-	3
CH3	0031	31	DIN000	NH000UD69V63PV	PC30UD69V63TF	-	3
CH3	0038	38	DIN000	NH000UD69V100PV	PC30UD69V100TF	-	3
CH3	0045	45	DIN000	NH000UD69V100PV	PC30UD69V100TF	-	3
CH3	0061	61	DIN00	NH00UD69V125PV	PC30UD69V125TF	-	3
CH4	0072	72	DIN00	NH00UD69V200PV	PC30UD69V200TF	-	3
CH4	0087	87	DIN00	NH00UD69V200PV	PC30UD69V200TF	-	3
CH4	0105	105	DIN00	NH00UD69V200PV	PC30UD69V200TF	-	3
CH4	0140	140	DIN1	NH1UD69V315PV	PC30UD69V315TF	-	3
CH5	0168	168	DIN1	NH1UD69V315PV	PC30UD69V315TF	-	3
CH5	0205	205	DIN1	NH1UD69V400PV	PC30UD69V400TF	-	3
CH5	0261	261	DIN2	NH2UD69V500PV	PC31UD69V500TF	-	3
CH61	0300	300	DIN3	NH3UD69V630PV	PC32UD69V630TF	-	3
CH61	0385	385	DIN3	NH3UD69V630PV	PC32UD69V630TF	-	3
CH62	0460	460	DIN3	NH3UD69V1000PV	PC33UD69V1000TF	-	3
CH62	0520	520	DIN3	NH3UD69V1000PV	PC33UD69V1000TF	-	3
CH62	0590	590	DIN3	PC73UB69V1100PA	PC33UD69V1100TF	-	3

Table 66. Fuse sizes for VACON® NX AFE units (380—500V)

Chassis	Type	I _{th} [A]	Fuse size	DIN43620	'TTF' threaded end	'TTF' threaded end	Qty. of fuses / drive 3~
				aR fuse part nr.	aR fuse part nr.	aR fuse part nr.	
CH62	0650	650	DIN3	PC73UB69V1250PA	PC33UD69V1250TF	-	3
CH62	0730	730	DIN3	PC73UB69V1250PA	PC33UD69V1250TF	-	3
CH63	0820	820	DIN3	NH3UD69V800PV	PC32UD69V800TF	PC44UD75V16CTQ	6 (3)
CH63	0920	920	DIN3	NH3UD69V1000PV	PC33UD69V1000TF	PC44UD75V16CTQ	6 (3)
CH63	1030	1030	DIN3	NH3UD69V1000PV	PC33UD69V1000TF	PC44UD75V18CTQ	6 (3)
CH63	1150	1150	DIN3	PC73UB69V1100PA	PC33UD69V1100TF	PC44UD75V20CTQ	6 (3)
CH64	1370	1370	DIN3	NH3UD69V1000PV	PC33UD69V1000TF	PC44UD75V24CTQ	9 (3) ¹
CH64	1640	1640	DIN3	NH3UD69V1000PV	PC33UD69V1000TF	PC44UD70V27CTQ	9 (3) ¹
CH64	2060	2060	DIN3	PC73UB69V1250PA	PC33UD69V1250TF	PC44UD69V34CTQB	9 (3) ¹
CH64	2300	2300	DIN3	PC73UB69V1250PA	PC33UD69V1250TF	PC47UD70V36CP50	9 (3) ¹

Table 67. Fuse sizes for VACON® NX AFE units (525—690 V)

Chassis	Type	I _{th} [A]	DIN43620		TTF threaded end "7X" or size 83 with end contacts	TTF threaded end contacts in size 83 or size 84	Qty. of fuses / drive 3~
			Fuse size	aR fuse part nr.			
CH61	0170	170	DIN1	PC71UD13C315PA	PC71UD13C315TF	-	3
CH61	0208	208	DIN1	PC71UD13C400PA	PC71UD13C400TF	-	3
CH61	0261	261	DIN1	PC73UD13C500PA	PC73UD13C500TF	-	3
CH62	0325	325	DIN3	PC73UD13C630PA	PC73UD13C630TF	-	3
CH62	0385	385	DIN3	PC73UD13C630PA	PC73UD13C630TF	-	3
CH62	0416	416	DIN3	PC73UD11C800PA	PC73UD13C800TF	-	3
CH62	0460	460	DIN3	PC73UD11C800PA	PC73UD13C800TF	-	3
CH62	0502	502	DIN3	PC73UD10C900PA	PC73UD13C800TF	-	3
CH63	0590	590	DIN3	PC73UD90V11CPA	PC73UD95V11CTF	-	3
CH63	0650	650	DIN3	PC73UD90V11CPA	PC73UD95V11CTF	-	3
CH63	0750	750	DIN3	PC73UD13C630PA	PC73UD13C630TF	PC83UD11C13CTF	6(3) ¹
CH64	0820	820	DIN3	PC73UD11C800PA	PC73UD13C800TF	PC83UD11C14CTF	6(3) ¹
CH64	0920	920	DIN3	PC73UD11C800PA	PC73UD13C800TF	PC83UD95V16CTF	6(3) ¹
CH64	1030	1030	DIN3	PC73UD90V11CPA	PC73UD95V11CTF	PC84UD12C18CTQ	6(3) ¹
CH64	1180	1180	DIN3	PC73UD90V11CPA	PC73UD95V11CTF	PC84UD11C20CTQ	6(3) ¹
CH64	1300	1300	DIN3	PC73UD11C800PA	PC73UD13C800TF	PC84UD11C22CTQ	9(3) ¹
CH64	1500	1500	DIN3	PC73UD90V11CPA	PC73UD95V11CTF	PC84UD11C24CTQ	9(3) ¹
CH64	1700	1700	DIN3	PC73UD90V11CPA	PC73UD95V11CTF	PC84UD90V30CTQ	9(3) ¹

For DC fuse selection use table for liquid cooled inverters (page 75).

¹ Quantity of fuses needed of TTF types PC4***** and PC8*****.

10.8 PRE-CHARGING CIRCUIT

The Active Front End unit requires an external pre-charging circuit. The purpose of the pre-charging unit is to charge the voltage in the intermediate circuit to a level sufficient for connecting the Active Front End unit to the mains. The charging time depends on the capacitance of the intermediate circuit and the resistance of the charging resistors. The technical specifications of manufacturer's standard pre-charging circuits are shown in Table 68. Pre-charging circuits are suitable for 380-500 Vac and 525-690 Vac.

The pre-charging components can be ordered separately. Components of the pre-charging circuit are 2 pcs charging resistors, the contactor, the diode bridge and the snubber capacitor, see Table 69. Each pre-charging circuit has maximum charging capacity, see Table 68. If the capacitance of the intermediate circuit in the system exceeds the values shown, contact your nearest distributor.

Table 68. Capacitance Min and Max value for Pre-charging circuit

Pre-charging circuit ratings			
Pre charging type	Resistance	Capacitance Min	Capacitance Max
CHARGING-AFE-FFE-FI9	2 x 47 R	4950 μ F	30000 μ F
CHARGING-AFE-FFE-FI10	2 x 20 R	9900 μ F	70000 μ F
CHARGING-AFE-FFE-FI13	2 x 11 R	29700 μ F	128000 μ F

Table 69. Type designation code for the pre-charging components configuration

FI9 AFE / CHARGING-AFE-FFE-FI9				
Item	Q'ty	Description	Manufacturer	Product Code
1	1	Diode Bridge	Semikron	SKD 82
2	2	Charging resistors	Danotherm	CAV150C47R
3	1	Snubber capacitor	Rifa	PHE448
4	1	Contactor	Telemecanique	LC1D32P7

FI10 AFE / CHARGING-AFE-FFE-FI10				
Item	Q'ty	Description	Manufacturer	Product Code
1	1	Diode Bridge	Semikron	SKD 82
2	2	Charging resistors	Danotherm	CBV335C20R
3	1	Snubber capacitor	Rifa	PHE448
4	1	Contactor	Telemecanique	LC1D32P7

FI13 AFE / CHARGING-AFE-FFE-FI13				
Item	Q'ty	Description	Manufacturer	Product Code
1	1	Diode Bridge	Semikron	SKD 82
2	2	Charging resistors	Danotherm	CBV335C11R

F113 AFE / CHARGING-AFE-FFE-F113				
3	1	Snubber capacitor	Rifa	PHE448
4	1	Contactor	Telemecanique	LC1D32P7

The Active Front End unit must not be connected to mains without pre-charging. In order to ensure the correct operation of the pre-charging circuit, the input circuit-breaker or contactor, as well as the pre-charging circuit contactor, must be controlled by the Active Front End unit. The input circuit-breaker or contactor as well as the pre-charging circuit contactor must be connected as shown in Figure 94.

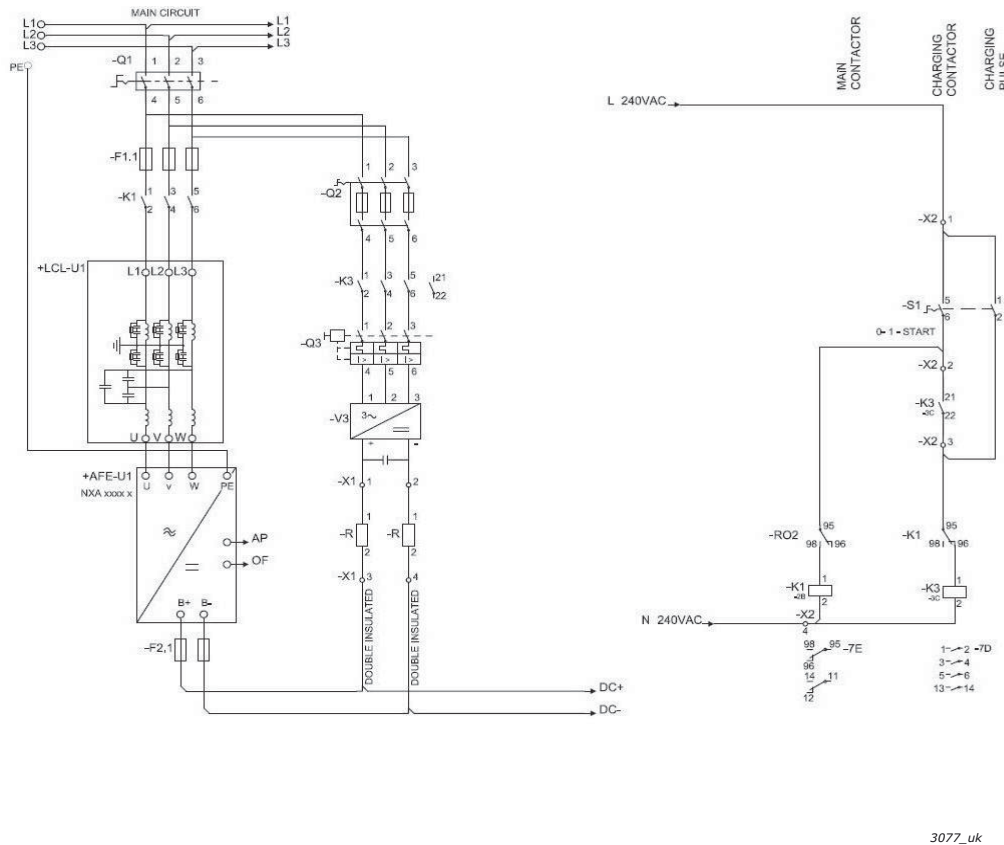

Figure 94. Wiring diagram for AFE unit

The example shown in Figure 94 uses a spring-return switch. The switch has positions 0-1-START. The spring returns the switch from position START to position 1. To start the pre-charging, the switch is turned from position 0 via 1 to START. When pre-charging starts, the switch can be released and it returns to position 1. No other control measures are required. The Active Front End application controls the main contactor of the system with Relay Output RO2, see Figure 95. When pre-charging of the intermediate circuit is ready the main contactor will be closed. The status of the main contactor is monitored via digital input (Default is DIN4). As a default the main contactor monitoring is ON but it can be set OFF with parameter. The main contactor should not be possible close without pre-charging.

To open the main contactor, simply turn the switch to 0. The contactor should not be opened under load. Opening the contactor under load will shorten its service life.

NOTE! Wirings what are used for connecting the pre-charging circuit to the intermediate circuit has to be double insulated.

NOTE! Enough space must be reserved around the resistors to ensure sufficient cooling. Don't place any heat sensitive components near the resistors.

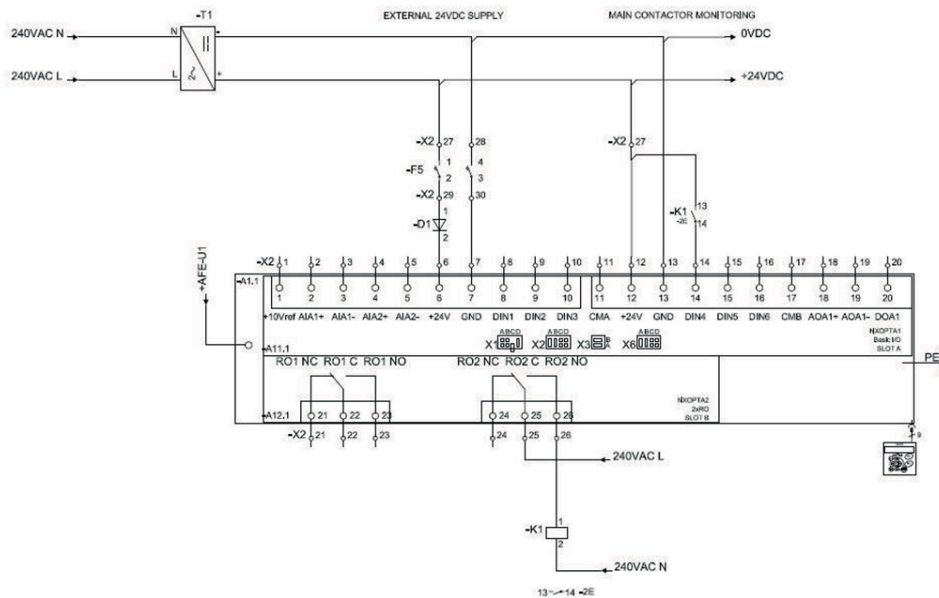

11402 uk

Figure 95. Wiring diagram for control unit

10.9 PARELLING

The power of the input group can be increased by connecting several Active Front End units in parallel. Paralleling refers to Active Front End units connected in the same input transformer. Active Front End units of different power ratings can also be connected in parallel. No communication between the units is required; they work independently. Manufacturer's standard LCL filters must be used for paralleling. If LCL filters other than these are used in Active Front End units connected in parallel, too large circulation currents may be generated between the Active Front End units. All Active Front units must be set for 5% drooping and PWM Synch must be set for Enable. See the Application manual for specific parameter settings.

Each Active Front End unit connected in parallel must have its own short-circuit protection on AC and DC sides. The fuses are selected in accordance with Section x-x. When paralleling, attention must be paid to the sufficient short-circuit capacity of the system.

The derating of Active Front End units connected in parallel is 5% of the DC power; this should be taken into account when selecting the input unit.

If a device is to be isolated from the AC and DC voltages, and other Active Front End units connected in parallel are also to be used, separate isolators are required in the AC input and DC output. The AC input can be isolated using a compact circuit-breaker, an ordinary circuit-breaker or a fuse switch. Contactors are not suitable for isolating the AC input because they cannot be locked in the safe position. The DC output can be isolated using a fuse switch. The pre-charging circuit must also be isolated from the AC input. A load isolation switch or safety isolation switch can be used for this. The device can also be connected to mains even when the other devices connected in parallel are already connected and running. In such a case, the isolated device must first be pre-charged. When that is done, the AC input can be switched on. After this, the device can be connected to the intermediate DC circuit.

10.10 COMMON PRE-CHARGING CIRCUIT

In case of paralleled Active Front End units, one common pre-charging circuit can be used, see Figure 96. Standard pre-charging circuits can be used if the capacitance of the intermediate circuit not exceeds maximum value. If all paralleled Active Front End units have a common circuit breaker, the breaker can be controlled by one of the Active Front End units. If each paralleled Active Front End unit has its own circuit breaker, each Active Front End controls it's own circuit breaker. The circuit diagram for control, see Figure 94 and Figure 95.

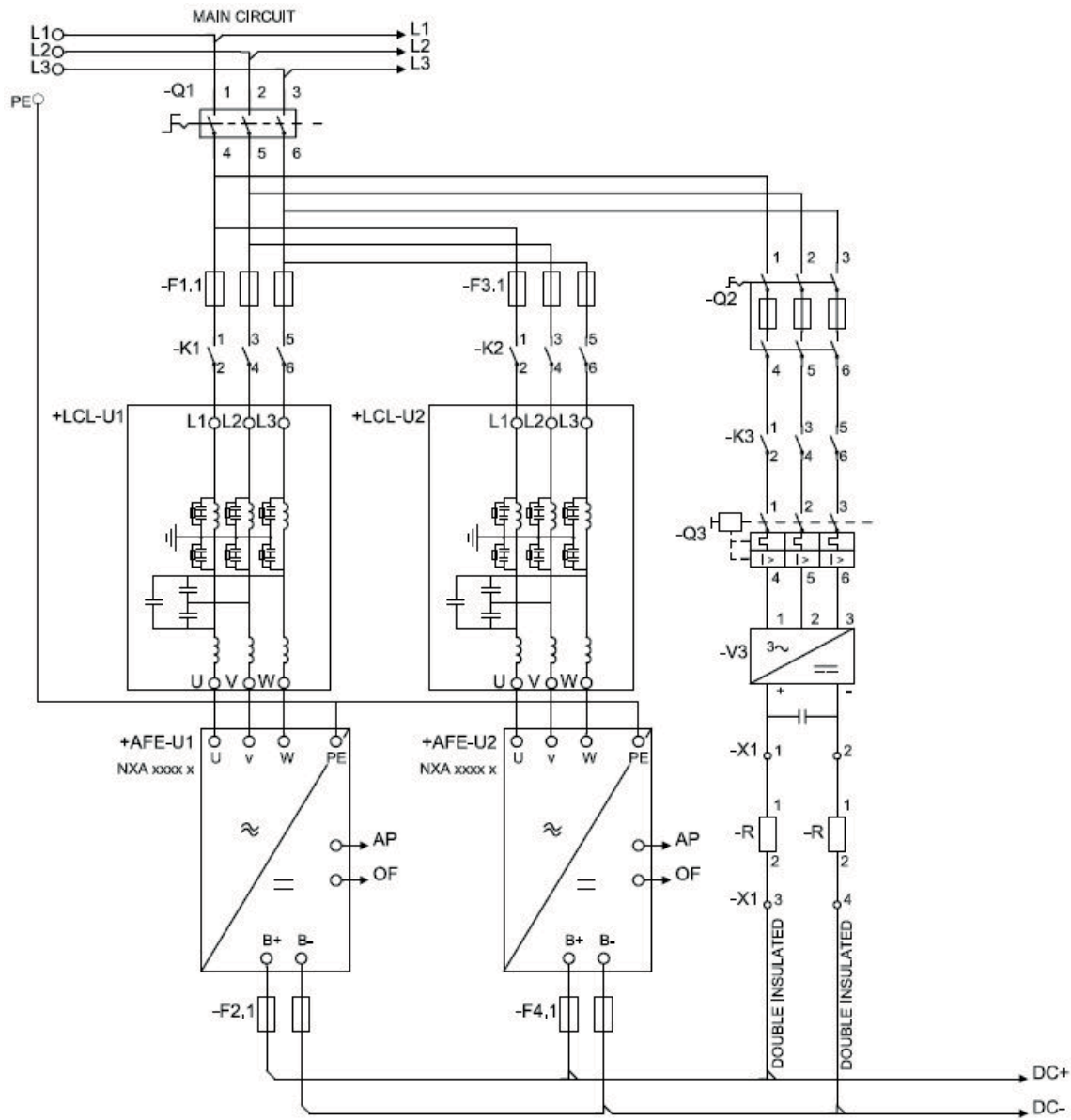

3079_uk

Figure 96. Active Front End units parallel connection with one common pre-charging circuit

10.11 EACH ACTIVE FRONT END UNIT HAS THE PRE-CHARGING CIRCUIT

Each Active Front End can have an own pre-charging circuit, and each unit is controlling it's own pre-charging and main contactor, see Figure 97. One control switch can be used but if an Active Front End unit needs to be controlled independently, separate switches are needed. With this the system is more redundant than with a common pre-charging circuit. The circuit diagram for control, see Figure 94 and Figure 95.

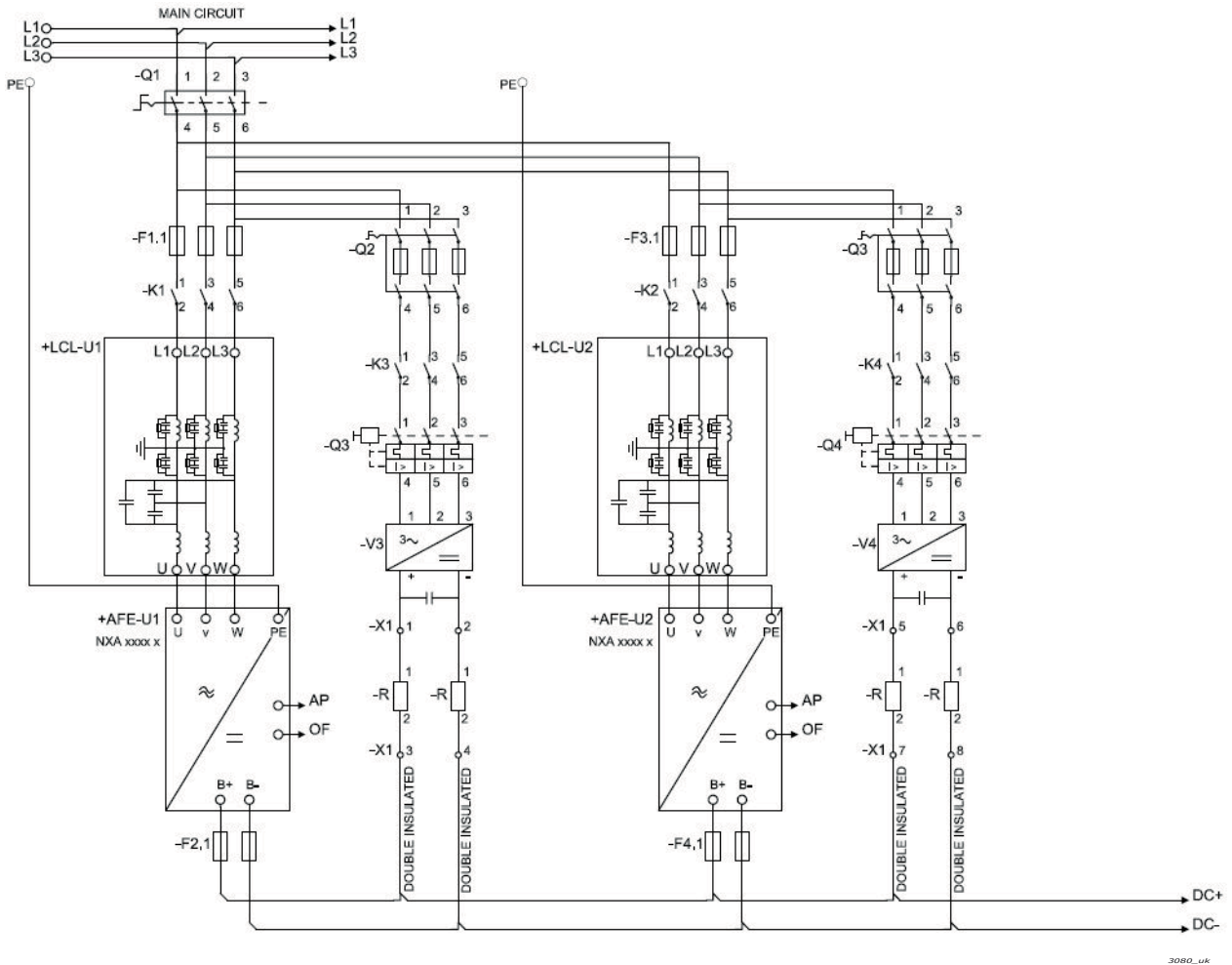

Figure 97. Active Front End units parallel connection with own pre-charging circuits

11. NON-REGENERATIVE FRONT END

11.1 INTRODUCTION

The VACON® NX Non-regenerative Front End (NFE) is used to transfer power from the AC input to the intermediate DC circuit to which the inverter units are connected.

The Non-regenerative Front End configurations consist of the unit itself, choke, pre-charging circuit, control unit with accessories, AC fuses, circuit breaker and DC fuses which you need to take into account when planning the switchgear configuration, see Figure 98. The construction is for 12-pulse network but it can be used as 6-pulse.

Other accessories such as breakers, fuses and pre-charging components etc should be acquired separately.

NOTE! If you use other chokes than the recommended ones, contact your nearest distributor to ensure compatibility.

Scope of supply:

The NFE unit consists of the power module (-TB1), NXP control (-AA1) and its option boards, control accessories and a choice of chokes (-RA1.1 and -RA1.2). The option board type is fixed A1A2BHB100. The option board for fieldbus can be ordered separately and is assembled into the slot E.

These external control accessories need to be assembled separately:

- 2 pieces of input phase monitor relays (-PRM1.1 and -PRM1.2)
- DC-voltage transducer 1500Vdc-10Vdc (-KF10)

11.2 DIAGRAMS

11.2.1 NON-REGENERATIVE FRONT END UNIT WIRING DIAGRAMS

The NFE unit has a typical control circuit. Some of the inputs and outputs can be set with parameters for optional purposes. See the parameter list in Chapter 11.13.

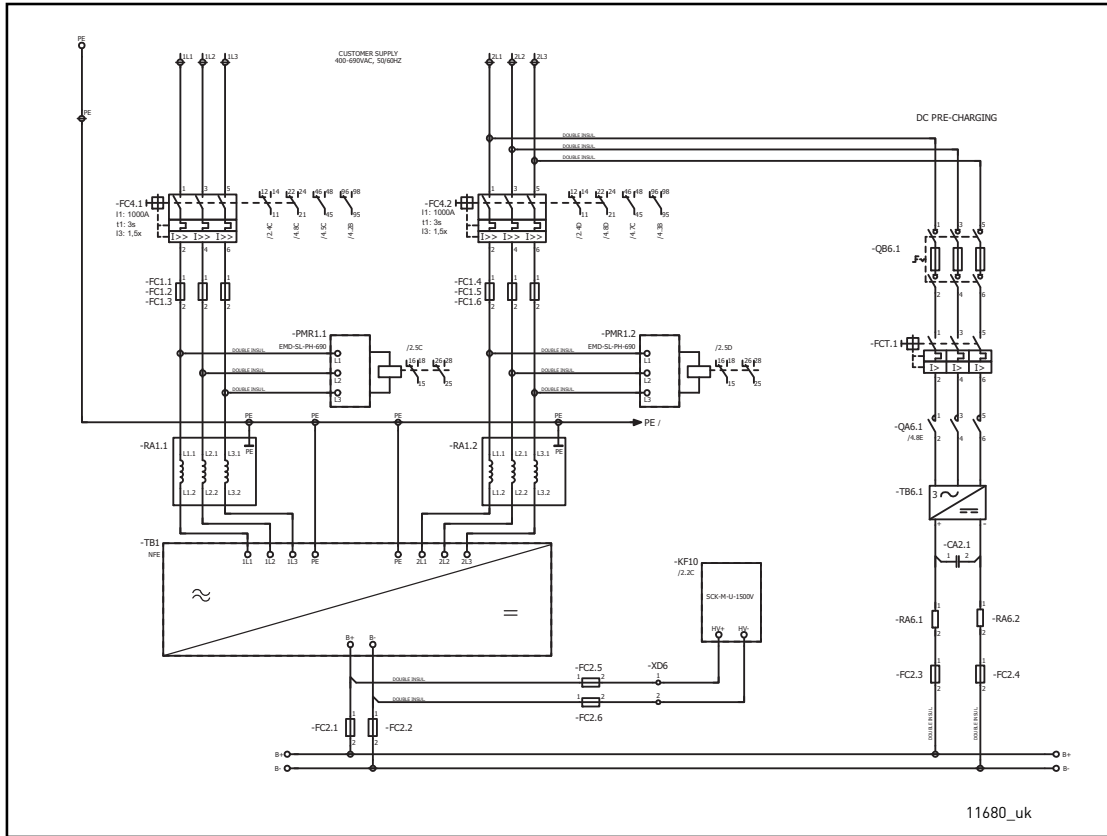

Figure 98. Wiring diagram for NFE unit

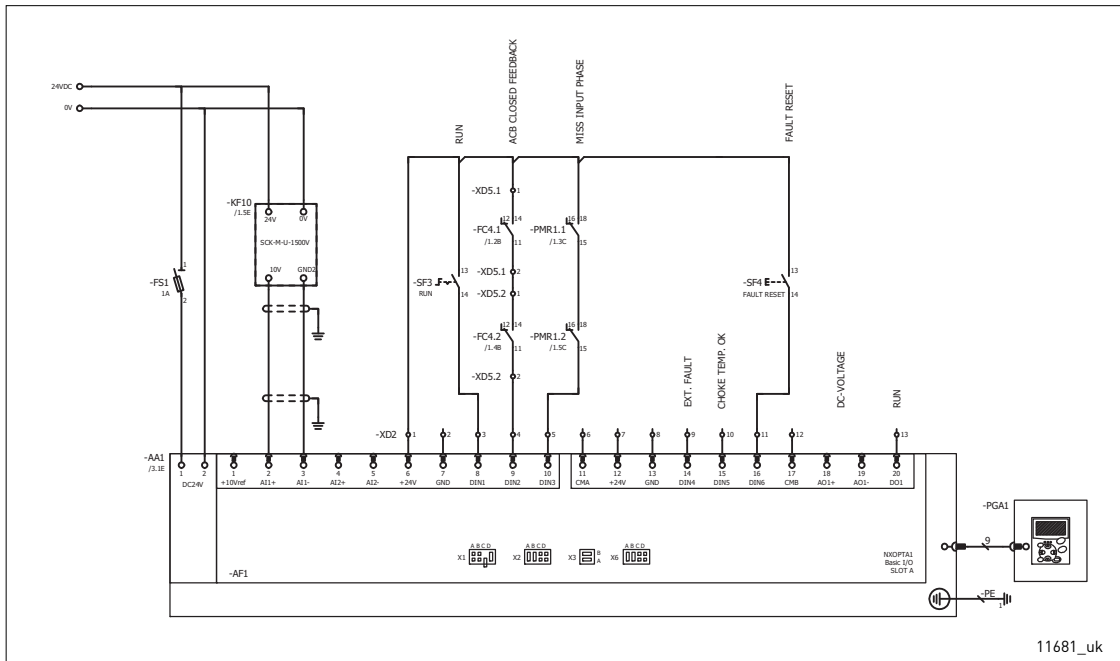

Figure 99. Wiring diagram for controls, OPTA1.

NOTE! The NXP control requires a minimum of 1A external 24Vdc power supply.

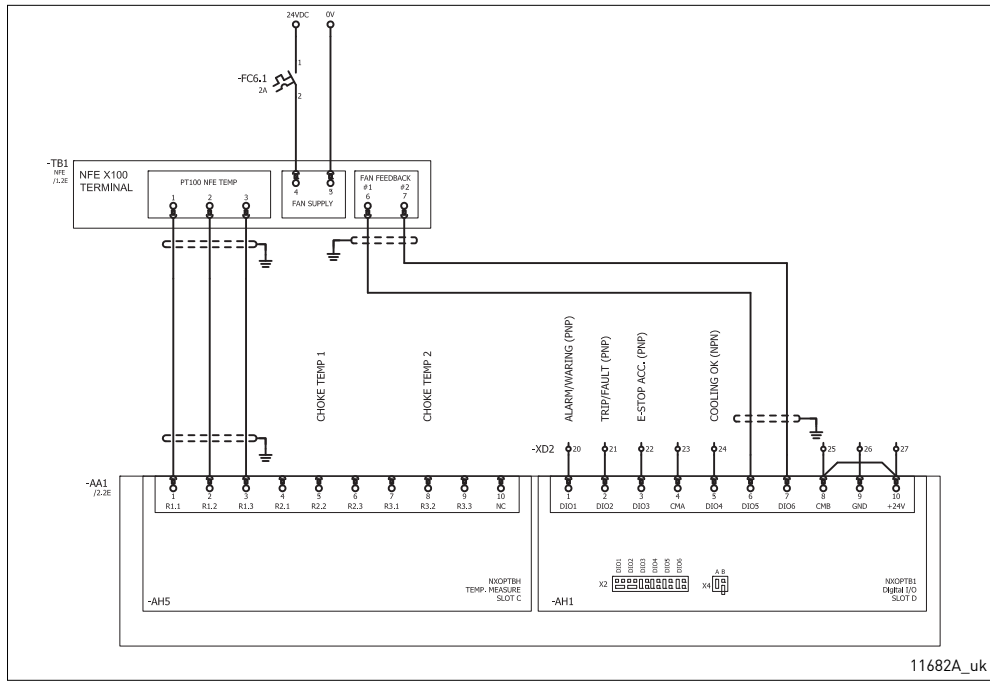

Figure 100. Wiring diagram for controls, OPTBH, OPTB1

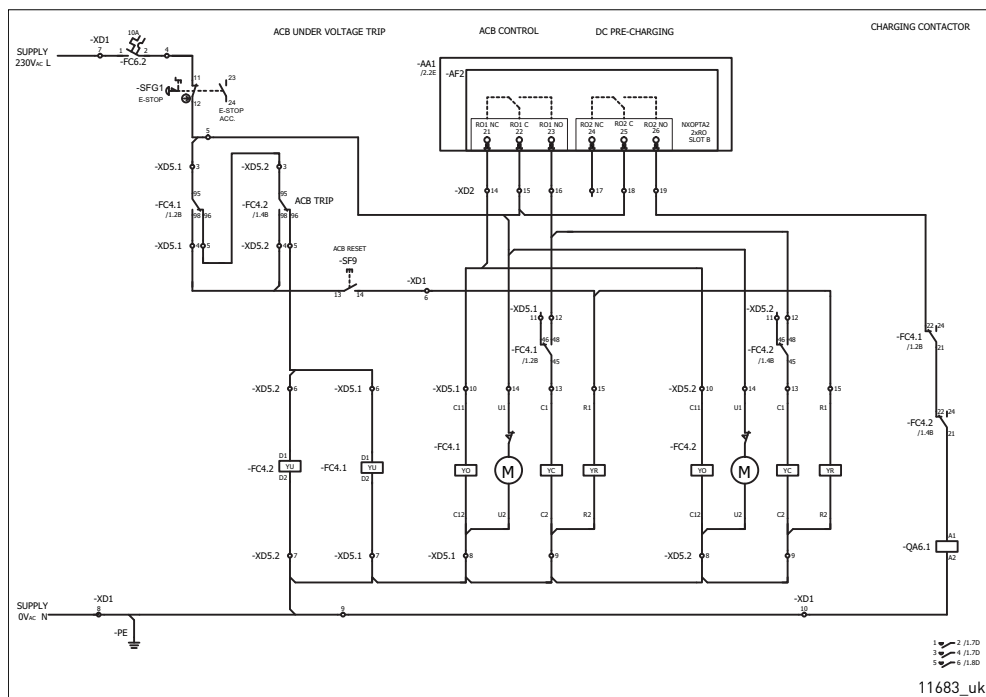

Figure 101. Wiring diagram for controls, OPTA2

The NFE power unit, NXP Control and the external control accessories need external 24Vdc supply. A minimum of 2A power is required to ensure proper operation. See the connection from circuit diagrams Figure 98 - Figure 101. The cable between the NXP control and the power unit has to be shielded and grounded using the cable clamp which is included in the delivery of the drive.

The main circuit breaker control requires typically external 230Vac, and a minimum of 2A.

11.3 INSTALLATION OF THE NFE CONTROL CABLES

A 24Vdc power supply for fans, fan feedback signals and PT100 temperature sensor must be connected to the X100 connector on the NFE module.

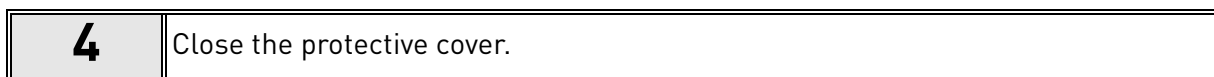
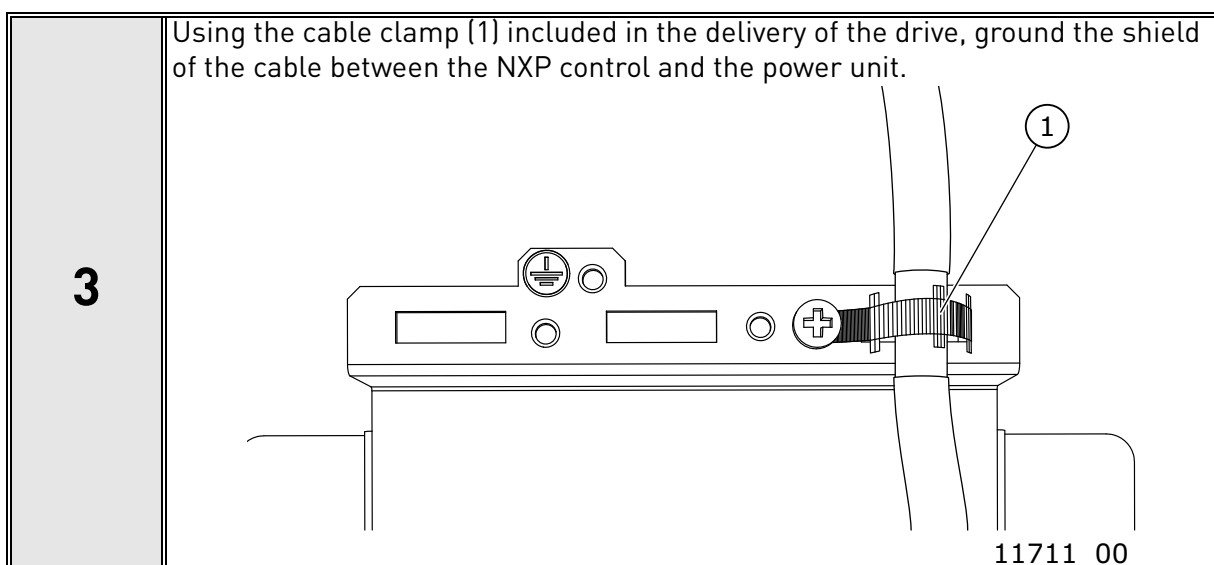
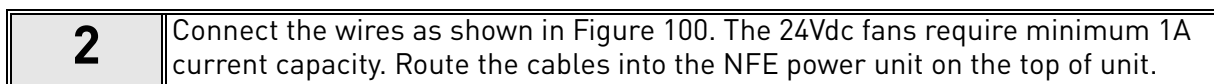
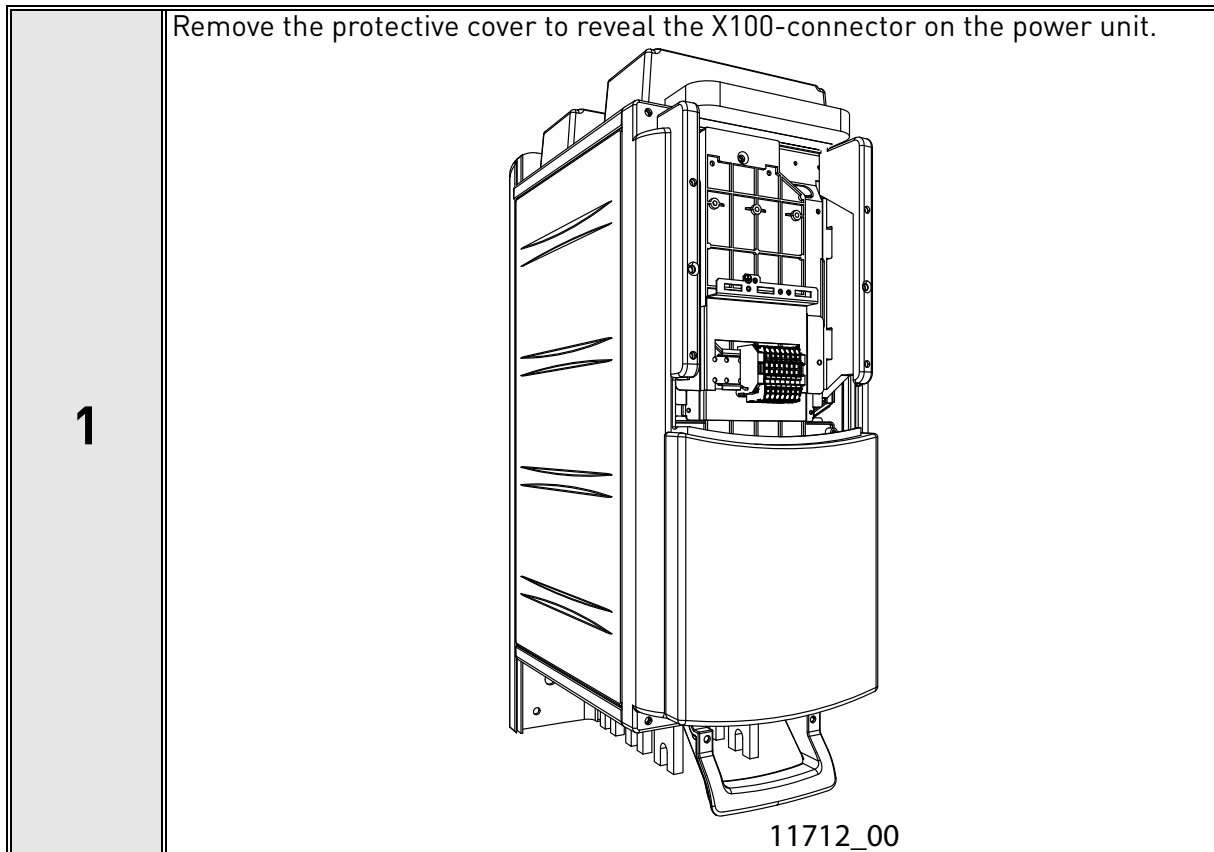

11.4 TYPE DESIGNATION CODES

In Vacon type designation code, the Non-regenerative Front Unit is characterized by the characters **NXN**. The codes are given below:

NXN	2000	6	A	0	T	0	UWV	A1A2BHB100	without chokes
NXN	2000	6	A	0	T	0	TWV	A1A2BHB100	with external air-cooled chokes
NXN	2000	6	A	0	T	0	WVW	A1A2BHB100	with external liquid-cooled chokes

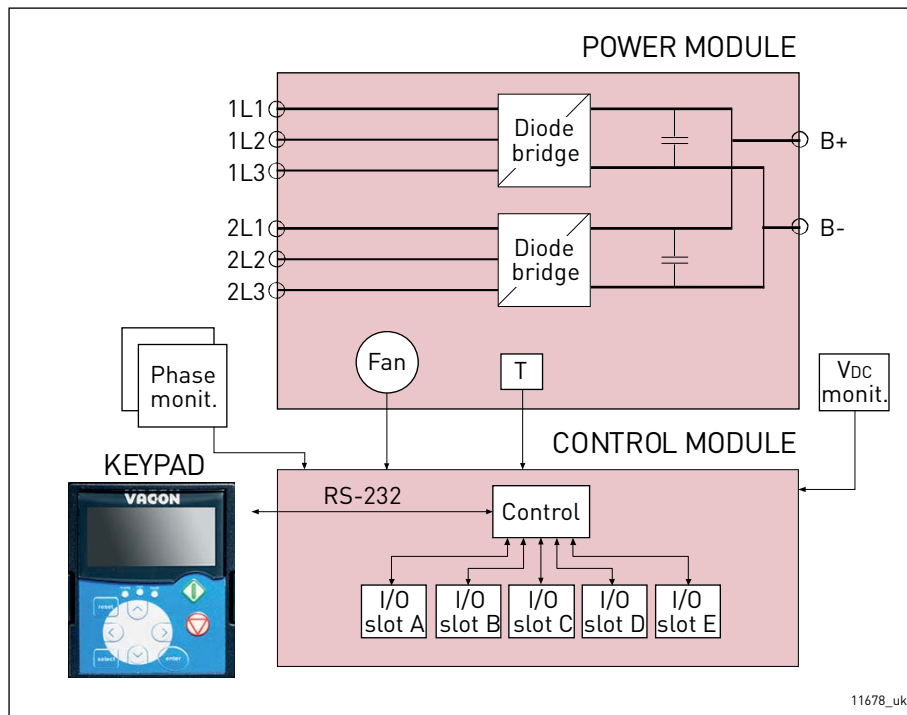

Figure 102. Non-regenerative front end block diagram

11.5 POWER RATINGS

Table 70. VACON® NXN Liquid-Cooled non regenerative front-end, DC bus voltage 465-800 VDC

AC drive type	AC current			DC power				Power loss c/a/T*) [kW]	Chassis
	Thermal I_{th} [A]	Rated I_L [A]	Rated I_H [A]	400 VAC mains I_{th} [kW]	500 VAC mains I_{th} [kW]	400 VAC mains I_L [kW]	500 VAC mains I_L [kW]		
NXN20006A0T0	2000	1818	1333	1282	1605	1165	1458	5.7/0.5/6.2	CH60

Table 71. VACON® NXN Liquid-Cooled non regenerative front-end, DC bus voltage 640-1100 VDC

AC drive type	AC current			DC power				Power loss c/a/T*) [kW]	Chassis
	Thermal I_{th} [A]	Rated I_L [A]	Rated I_H [A]	525 VAC mains I_{th} [kW]	690 VAC mains I_{th} [kW]	525 VAC mains I_L [kW]	690 VAC mains I_L [kW]		
NXN20006A0T0	2000	1818	1333	1685	2336	1531	2014	5.7/0.5/6.2	CH60

11.6 NON-REGENERATIVE FRONT END UNIT TECHNICAL DATA

The technical data for the non-regenerative front end unit, see table below.

Table 72. Technical data

Mains connection	Input voltage U_{in}	2 x 3ph 400...690 VAC (-10%...+10%);
	Input frequency	45...66 Hz
Output connection	Output voltage	$U_{in} \times 1.35$
	Output frequency	DC-voltage
	DC bank capacitance	4800 μ F
Control characteristics	External NXP control	Run/Stop Control and supervision for external DC precharging circuit Control and supervision for external ACB's DC-voltage supervision Input phase and undervoltage supervision Choke temperature supervision Unit temperature supervision Fan operation supervision Optional current monitor
Current capacity	Input current	$I_{th} 2 \times 1000A_{AC}$
	Output current	$I_{th} 2400A_{DC}$
	Overload	No overload
	Power losses	Power loss into coolant: 5.7 kW Power loss into air: 0.5 kW Power losses of the chokes: see Table 76.
Ambient conditions	Ambient operating temperature	-10 °C (no frost)...+50 °C (at I_{th}) The NX Liquid-Cooled drives must be used in an heated indoor controlled environment.
	Installation temperature	0...+70 °C
	Storage temperature	-40 °C...+70 °C; No liquid in heatsink under 0 °C
	Relative humidity	5 to 96% RH, non-condensing, no dripping water
	Air quality: • chemical vapours • mechanical particles	No corrosive gases IEC 60721-3-3, unit in operation, class 3C2 IEC 60721-3-3, unit in operation, class 3S2 (no conductive dust allowed)
	Altitude	400...500 V: 3000m ASL; in case network is not corner grounded 500...690 V: max. 2000m ASL
	Vibration	5...150 Hz
	Shock EN 50178, EN 60068-2-27	UPS Drop Test (for applicable UPS weights) Storage and shipping: max 15 G, 11 ms (in package)
Enclosure class	IP00/Open	

Table 72. Technical data

EMC	Immunity	Fulfils IEC/EN 61800-3 EMC immunity requirements.
	Emissions	EMC level N for TN/TT networks EMC level T for IT networks
Safety		IEC/EN 61800-5-1 IEC/EN 60204-1 as relevant, (see unit nameplate for more details)
Approvals	Type tested	CE, cULus
	Type approval	
Liquid cooling	Allowed cooling agents	Drinking water (see specification in chapter 5.2) Water-glycol mixture See derating specifications, Table 7
	Temperature of cooling agent	0...43°C input (I_{th}); 43...55°C, contact your local distributor for further information Temperature rise during circulation max. 5°C No condensation allowed
	Cooling agent flow rates	See Table 6.
	System max. working pressure	6 bar
	System max. peak pressure	30 bar
	Pressure loss (at nom. flow)	See Table 8.
Protections		Undervoltage, overvoltage, mains supervision, unit undertemperature, overtemperature, cooling fan operation, ACB operation, DC precharging operation, choke temperature

11.7 DIMENSIONS

Table 73. Non-regenerative front-end unit dimensions

Chassis	Width [mm]	Height [mm]	Depth [mm]	Weight [kg]
CH60	246	673	374	55

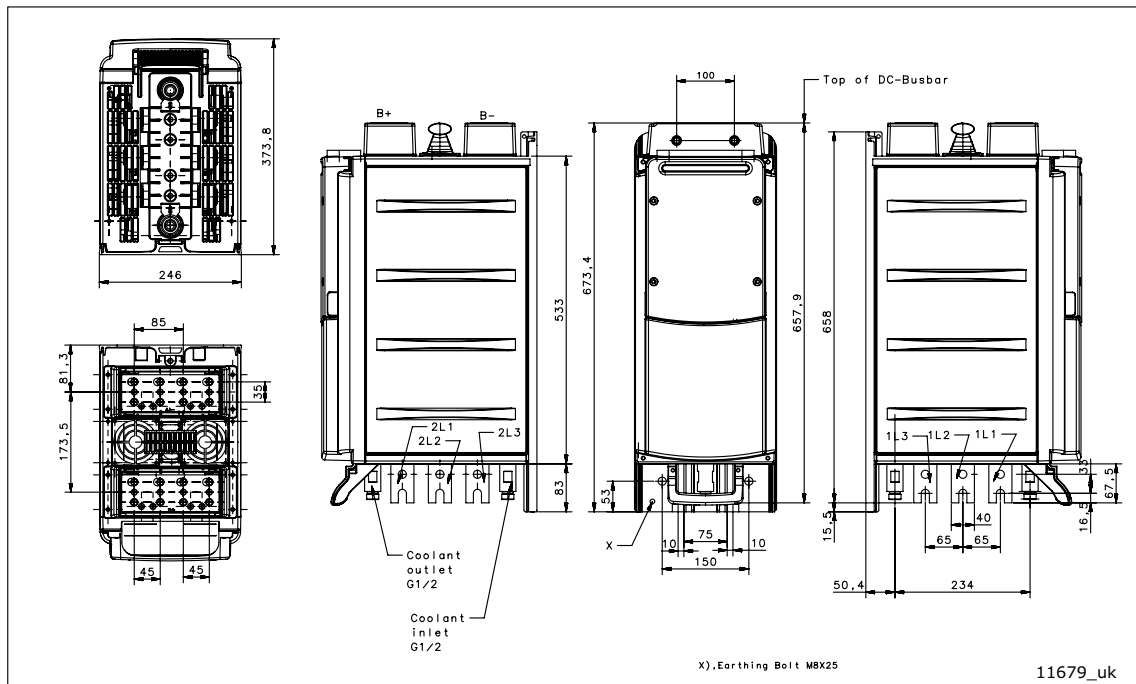

Figure 103. VACON® Liquid-cooled Non-regenerative front end, CH60

Table 74. Terminal connection

Chassis	Earth terminal (mm ²)	Eart terminal Bolt size	Main terminal Bolt size per phase	DC terminal Bolt size per polarity
CH60	25-185	M8	2 x M12	8 x M12

Table 75. Tightening torque of bolts

Bolt	Torque (Nm)	Max inward length (mm)
Grounding bolt	13.5	-
M12	70	22

11.8 CHOKES

Table 76. Type and dimensions for air-cooled chokes

Choke type	Width [mm]	Height [mm]	Depth [mm]	Weight [kg]	Losses to air [W]	Losses to coolant [W]	Cooling
CHK1030N6A0	497	677	307	213	1170*	0	Air
FLU-CHK-1030-6-DL	506	676	302	237	1680	1180	Liquid

*) Losses for one choke. 2 chokes are needed for each L/C NFE, so total losses are 2x1.17 kW.

NOTE! If you use other chokes than the recommended ones, contact your nearest distributor to ensure compatibility.

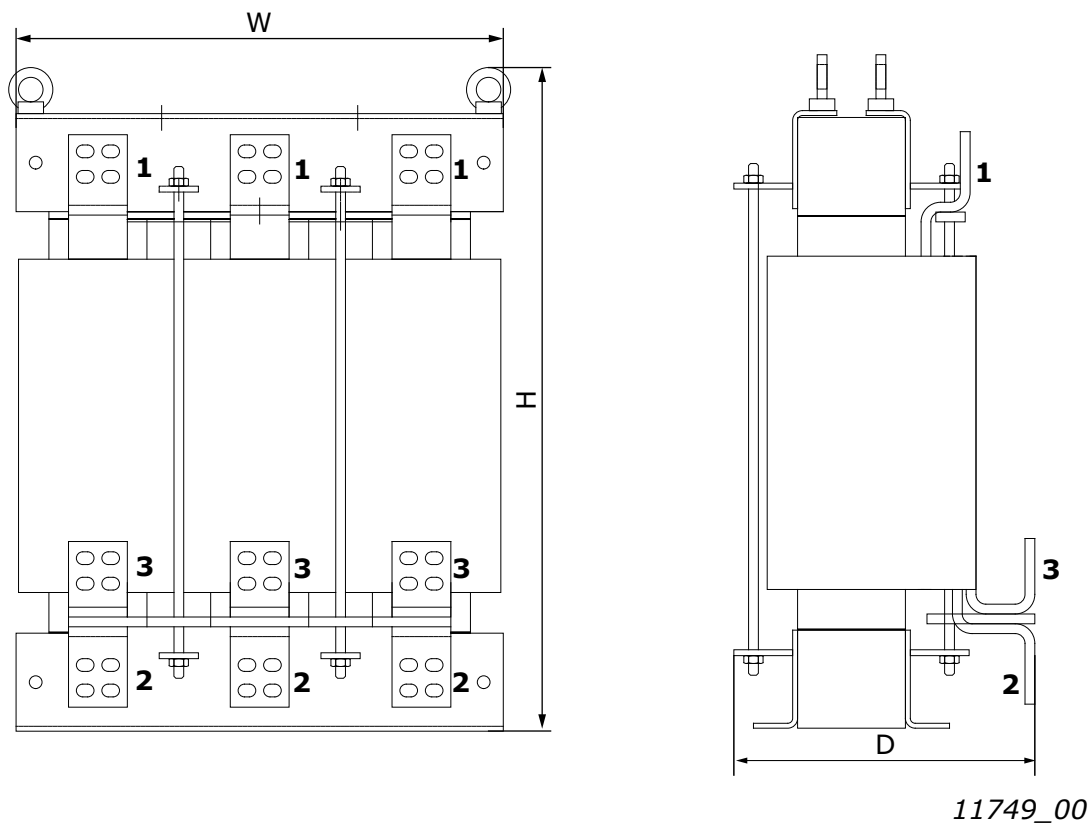

Figure 104. Example of CHK1030N6A0 choke

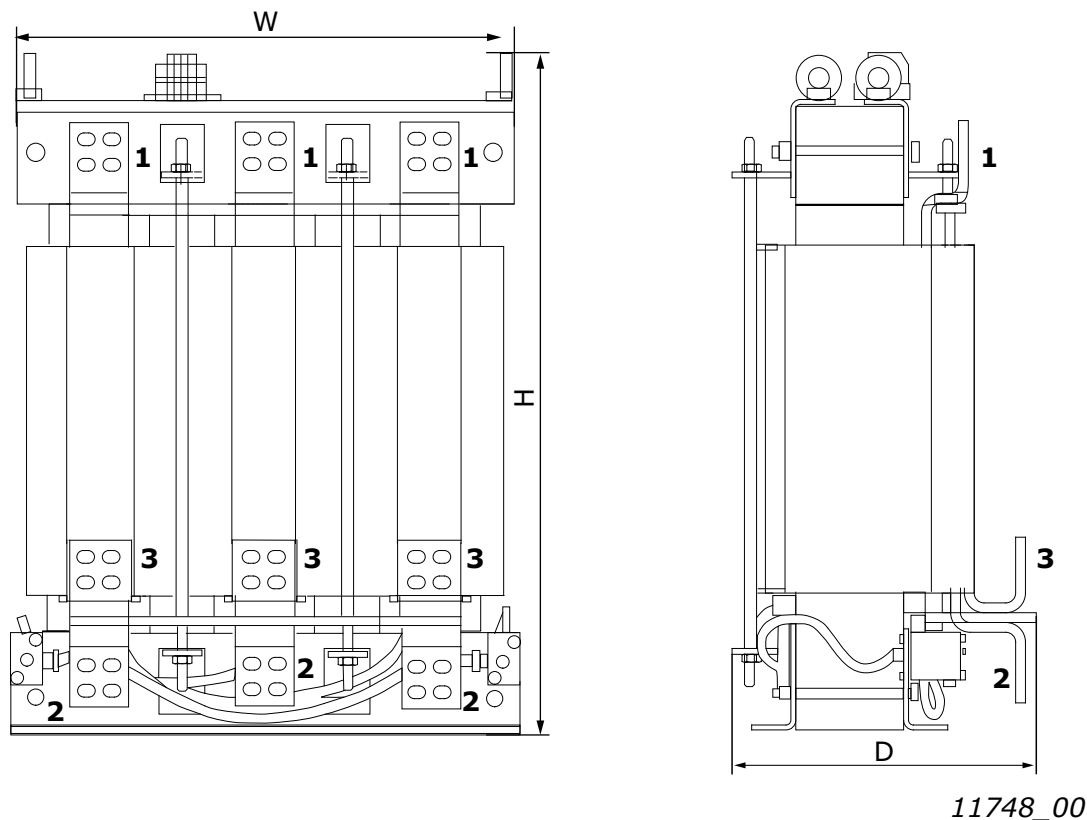

Figure 105. Example of FLU-CHK-1030-6-DL choke

Coolant connection G3/8" female thread.

Table 77.

Supply voltage	AC drive connection (terminal no.)
400-480 Vac	2
500 Vac	3
525-690 Vac	3

11.9 NON-REGENERATIVE FRONT END - FUSE SELECTION

AC fuses are used to protect the input network in case the Non-regenerative Front End unit or the choke is faulty. DC fuses are used to protect the Non-regenerative Front End unit and the choke in case there is a short circuit in the DC buses. If DC fuses are not used, short-circuit in the DC buses will cause a loading of the Non-regenerative Front End unit. Vacon Ltd will not assume any responsibility for damages caused by insufficient protection. **The warranty becomes void if the drive is not equipped with appropriate fuses.**

Main circuit breakers are used to protect chokes and Non-regenerative Front End units from overloading and unbalanced loading. Therefore, both rectifier bridges must be equipped with individual circuit breakers, see Figure 98.

Fuse information

The values in tables are based on max ambient temperature of +50 °C.

The required AC fuse type for the non-regenerative front end unit can be found from Table 78. The required DC fuse type for the non-regenerative front end unit can be found from Table 79.

11.9.1 FUSE SIZES, NON-REGENERATIVE FRONT END UNITS

Table 78. AC Fuse sizes for VACON® NX NFE units

Chassis	Code	Fuse, Mersen	U_N [V]	I_N [A]	Size	Bolts	Qty.
CH60	NXN 2000 6	PC233UD69V16CTF/ F300270A	690	1600	2x33	M12	6

Table 79. DC Fuse sizes for VACON® NX NFE units

Chassis	Code	Fuse, Mersen	U_N [V]	I_N [A]	Size	Bolts	Qty.
CH60	NXN 2000 6	PC87UD11C38CP50 / K302988A	1050	3800	284	M12	2

11.9.2 CIRCUIT BREAKER SETTINGS, NON-REGENERATIVE FRONT END UNITS

Table 80. Circuit breaker settings for VACON® NX NFE units

Type	Code	Type, ABB	Qty.	L		I	N
				I1	t1	I3	InN
NFE	NXN 2000 6	X1N16FF3PR331LI	2	0.625	3s	1.5	50%
		X1N12FF3PR331LI	2	0.825	3s	1.5	50%
		X1N10FF3PR331LI	2	1.000	3s	1.5	50%

NOTE! If other circuit breakers are used, the overload and short circuit characteristics must be similar than those of the circuit breakers mentioned above. Overload $I_N = 1000A_{AC}/3sec$, instantaneous short-circuit $I = 1500A_{AC}$. Note that IEC, UL and other related approvals may be required. For UL enclosures, use UL Listed Breakers with category code PAQX or DIVQ.

11.10 SETTINGS

11.10.1 PHASE MONITOR SETTINGS

The option boards and phase monitor relays have settings that you may need to adjust. For settings of software application parameters, see Chapter 11.13.

The phase monitor relays (PMR1.1 and PMR1.2) have functions to detect under voltage, phase sequence and phase failure. All of those have to be correct so that the power unit is powered

correctly and stays in run mode. If any of them is not correct, the phase monitor relay's output does not activate and the control unit gives an input phase fault.

1. **"U" Green LED: Supply voltage**
 - LED ON: Supply voltage present
2. **"MIN" Red LED: Lower threshold value (under voltage)**
 - LED flashes: Set threshold value exceeded, set delay time is running
 - LED ON: Set threshold value exceeded, delay time has elapsed
3. **"SEQ" Red LED: Phase failure/phase sequence**
 - LED flashing: phase has failed, set delay time is running
 - LED on: phase has failed, delay time has elapsed
4. **"REL" yellow LED: Output relay**
 - LED ON: Output relay has picked up (OK)
 - LED OFF: Output relay has dropped out (Fail)
5. **"Delay" potentiometer: response delay**
 - 400-690Vac: 0.1s
6. **"MIN" potentiometer: Lower threshold value**
 - 400-500Vac: $\geq 360\text{Vac}$
 - 500-690Vac: $\geq 450\text{Vac}$

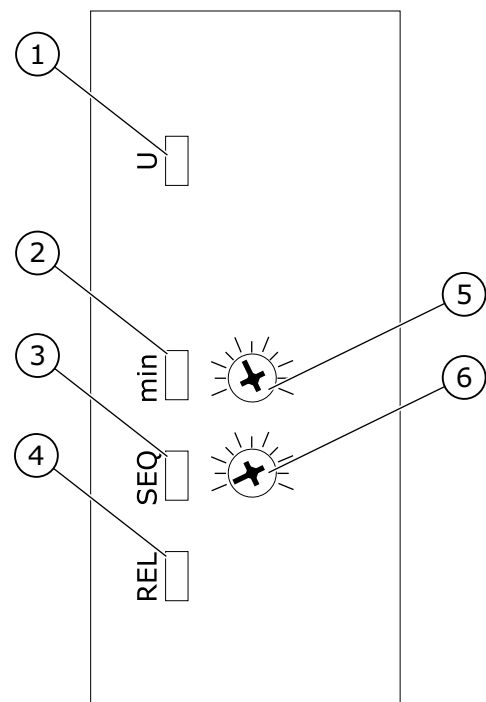

11684_00

11.10.2 OPTION BOARD SETTINGS

The NXP control has fixed option boards A1A2BHB100. The option boards have jumpers which you may need to set according to the external wiring and connections. See the VACON[®] NX I/O Board User manual for settings. Required board settings for default wiring diagram and components are given below:

Slot A, OPT-A1:

- X1, AI1 mode: voltage input 0...10V
- X2, AI2 mode: according to use
- X3, CMA and CMB grounding: Connected to GND
- X6, AO1 mode: according to use

Slot B, OPT-A2:

- No settings

Slot C, OPT-BH:

- G7.3 parameters as shown in Table 92.

Slot D, OPT-B1:

- X2, DIO mode: D01, D02, DI3, DI4, DI5, DI6
- X4: CMA grounding: Connected to GND. CMB grounding: Floating

Slot E: Reserved for optional board such as fieldbus

11.11 DC PRE-CHARGING CIRCUIT

Each Non-regenerative Front End unit requires its own external pre-charging circuit. The purpose of the pre-charging unit is to charge the voltage in the intermediate circuit to a level sufficient for connecting the Non-regenerative Front End unit to the mains. The charging time depends on the capacitance of the intermediate circuit of the total common DC-bus system and the resistance of the charging resistors. The technical specifications of manufacturer's standard pre-charging circuits are shown in Table 81. The pre-charging circuits are suitable for 400-500 Vac and 525-690 Vac.

The pre-charging duration and DC voltage level are monitored by the NXP control. The DC voltage level must be over 40VDC after 1 second charging and final pre-charging voltage level must be reached within the maximum charging time. If these conditions are not reached, a charging fault is issued. The maximum charging time can be set by a parameter.

The pre-charging components can be ordered separately. The pre-charging circuit includes the following components: 2 pcs charging resistors, the contactor, the diode bridge and the snubber capacitor, see Table 82. Each pre-charging circuit has maximum charging capacity, see Table 81. If the capacitance of the intermediate circuit in the total system exceeds the values shown, contact your nearest distributor.

Table 81. Capacitance Min and Max value for Pre-charging circuit

Pre-charging circuit ratings			
Pre charging type	Resistance	Capacitance Min	Capacitance Max
CHARGING-AFE-FFE-FI9	2 x 47 R	4950 µF	30000 µF
CHARGING-AFE-FFE-FI10	2 x 20 R	9900 µF	70000 µF
CHARGING-AFE-FFE-FI13	2 x 11 R	29700 µF	128000 µF

Table 82. Type designation code for the pre-charging components configuration

FI9 AFE / CHARGING-AFE-FFE-FI9				
Item	Q'ty	Description	Manufacturer	Product Code
1	1	Diode Bridge	Semikron	SKD 82
2	2	Charging resistors	Danotherm	CAV150C47R
3	1	Snubber capacitor	Rifa	PHE448
4	1	Contactor	Telemecanique	LC1D32P7

FI10 AFE / CHARGING-AFE-FFE-FI10				
Item	Q'ty	Description	Manufacturer	Product Code
1	1	Diode Bridge	Semikron	SKD 82
2	2	Charging resistors	Danotherm	CBV335C20R
3	1	Snubber capacitor	Rifa	PHE448
4	1	Contactor	Telemecanique	LC1D32P7

FI13 AFE / CHARGING-AFE-FFE-FI13				
Item	Q'ty	Description	Manufacturer	Product Code
1	1	Diode Bridge	Semikron	SKD 82
2	2	Charging resistors	Danotherm	CBV335C11R
3	1	Snubber capacitor	Rifa	PHE448
4	1	Contactor	Telemecanique	LC1D32P7

The Non-regenerative Front End unit must not be connected to mains without pre-charging. In order to ensure the correct operation of the pre-charging circuit, the input circuit-breaker and the pre-charging circuit contactor must be controlled by the Non-regenerative Front End unit. The input circuit-breaker and the pre-charging circuit contactor must be connected as shown in Chapter 11.2.1.

NOTE! You need to double-insulate all wirings that do not have short circuit protections and are used for connecting the pre-charging circuit to the intermediate circuit.

NOTE! Enough space must be reserved around the resistors to ensure sufficient cooling. Do not place any heat sensitive components near the resistors.

11.12 PARALLELING

The power of the input group can be increased by connecting several Non-Regenerative Front End units in parallel. Manufacturer's standard chokes must be used for parallel units. Use of other than these chokes in the Non-Regenerative Front End units connected in parallel may cause a too large current imbalance between the units.

Each Non-Regenerative Front End unit connected in parallel must have its own short-circuit protection on AC and DC sides and own circuit breakers in AC side. When paralleling, attention must be paid to the sufficient short-circuit capacity of the system.

The derating of Non-Regenerative Front End units connected in parallel is 10% of the DC power; this should be taken into account when dimensioning the system.

If a device is to be isolated from the AC and DC voltages, and other Non-Regenerative Front End units connected in parallel are also to be used, separate isolators are required in the AC input and DC output. The AC input can be isolated using a circuit-breaker or a fuse switch. Contactors are not suitable for isolating the AC input because they cannot be locked in a safe position. The DC output can be isolated using a proper load switch. The pre-charging circuit must also be isolated from the AC input by using fuse switch. The device can also be connected to mains even when the other devices connected in parallel are already connected and running. In such a case, the isolated device must first be pre-charged. When that is done, the AC input can be switched on. After this, the device can be connected to the intermediate DC circuit.

11.13 PARAMETERS

The parameters for software version ANCNQ100 are described below.

Table 83. Monitoring values

Code	Parameter	Min	Max	Unit	Default	ID	Description
V1.2.1	DC Voltage	0	1500	V	0	7	DC voltage measured by external AI devices
V1.2.2	Current	0	5000	A	0	3	Current measured by external AI devices
V1.2.3	Unit Temperature	-30.0	200.0	deg	0.0	8	Heatsink temp measured by PT100 signal
V1.2.4	Choke Temp 1	-30.0	200.0	deg	0.0	50	Choke temp 1 measured by PT100
V1.2.5	Choke Temp 2	-30.0	200.0	deg	0.0	43	Choke temp 2 measured by second PT100
V1.2.6	Status Word	0	65535		0	20	B0 =PrechargeReady B1 =MC RUN B2 =MC Warning B3 =MC Fault B4 =DIN Run B5 =DIN BreakerFeedback B6 =DIN MissInputPhase B7 =DIN ChokeTempFault B8 =DIN Reset B9 =DOUT DC Precharging B10=DOUT Close MCB B11=DIN Cooling Fan B12=DIN Cooling Fan2 Bit13=DIN External Fault Close Bit14=DIN E Stop Bit15=DIN Cooling OK
V1.2.7	Hour Counter	0	65535	Hour	0	1909	Run Hour counter

Table 84. Basic parameters G2.1

Code	Parameter	Min	Max	Unit	Default	ID	Description
P2.1.1	Main Voltage	400	690	V	690	1910	Main supply voltage from network
P2.1.2	PreChargReadyLev	20	100	%	80	1911	Precharge ready level
P2.1.3	MaxChargeTime	0.00	30.00	s	5.00	1912	Max charge time. If the charging time is more than this, a fault will generated
P2.1.4	Password	0	65535		0	1913	Password

Table 85. Digital input G2.2.1

Code	Parameter	Min	Max	Unit	Default	ID	Description
P2.2.1.1	Run	0	59		10	1915	Select Digital input signal for Run command

Table 85. Digital input G2.2.1

Code	Parameter	Min	Max	Unit	Default	ID	Description
P2.2.1.2	BreakerFeedback	0	59		11	1916	Select digital input signal for Breaker Feedback
P2.2.1.3	Miss Input Phase	0	59		12	1917	Select digital input for missing input phase or low input voltage
P2.2.1.4	External Fault	0	59		13	1918	Select for digital input signal external fault ,normal open logic
P2.2.1.5	Choke Temp	0	59		14	1919	Select for digital input Choke Temp
P2.2.1.6	Fault Reset	0	59		15	1920	Select for digital input signal fault reset
P2.2.1.7	E Stop	0	59		42	1921	Select for digital input signal E-stop feedback
P2.2.1.8	Cooling OK	0	59		43	1922	Select for digital input signal liquid cooling feedback
P2.2.1.9	Fan Sensor 1	0	59		44	1923	Select for digital input signal cooling fan monitor
P2.2.1.10	Fan Sensor 2	0	59		45	1924	Selection of fan sensor2 from digital input signal, default is from OPT-B1 DIN.D5

Table 86. Analog input G2.2.2

Code	Parameter	Min	Max	Unit	Default	ID	Description
P2.2.2.1	DC Voltage	0	59		10	1925	Selection for analog input of dc voltage
P2.2.2.2	DC Min Point	0.00	40.00	%	20.00	1926	Percent value corresponds to 0 dc voltage
P2.2.2.3	Max DC Voltage	500	2000	V	1500	1927	Dc voltage measurement devices max range
P2.2.2.4	Current	0	59		11	1928	Selection of analog input signal input current
P2.2.2.5	Current MinPoint	0.00	100.00	%	0.00	1929	Analog input signal min point for current measurement
P2.2.2.6	Max Current	0	32000	A	1000	1930	Max current corresponds to max analog input 100.00%
P2.2.2.7	Unit Temp	0	59		30	1931	Selection of analog input for heatsink Temp
P2.2.2.8	Choke Temp 1	0	59		31	1932	Select analog input signal for choke temp 1 from pt100 signal
P2.2.2.9	Choke Temp 2	0	59		32	1933	Select analog input signal for choke temp 2 from PT100 signal

Table 87. Digital Output G2.3.1

Code	Parameter	Min	Max	Unit	Default	ID	Description
P2.3.1.1	Running	0	59		10	1935	Select for digital output signal MC running
P2.3.1.2	Close MCB	0	59		20	1936	Selection for digital output close Main circuit breaker
P2.3.1.3	DC Precharge	0	59		21	1937	Selection digital output signal for DC Precharging signal
P2.3.1.4	Warning	0	59		40	1938	Select for digital output signal mc warning
P2.3.1.5	Fault	0	59		41	1939	Selection for digital output signal mc fault
P2.3.1.6	No Warning	0	59		0	1940	Inverted warning signal
P2.3.1.6	No Fault	0	59		0	1941	Inverted fault signal

Table 88. Analog Output G2.3.2

Code	Parameter	Min	Max	Unit	Default	ID	Description
P2.3.2.1	DC Voltage	0	59		10	1942	Selection for analog output signal dc voltage
P2.3.2.2	Current	0	59		0	1943	Selection for analog output signal for current

Table 89. Protection G2.4

Code	Parameter	Min	Max	Unit	Default	ID	Description
P2.4.1	CoolFanFaultMode	1	2		1	1945	Cooling Fan Fault Mode 1=Warning + Fault(after delay) 2=Fault
P2.4.2	Fan Fault Delay	0	15	min	5	1946	The delay time after which a cooling fan fault will generate. Until the delay time is finished, only a warning is on.
P2.4.3	MissPhaseFautMod	0	2		2	1947	Miss input phase fault response mode 0=no action 1=Warning 2=Fault
P2.4.4	MissPhaseFDelay	0.00	60.00	s	1.00	1948	Missing phase signal wait time
P2.4.5	BreakerFaultMode	0	2		2	1949	MCB feedback signal is missing after settled time 0=No action 1=Warning 2=Fault
P2.4.6	Breaker Ack Time	0.00	10.00	s	1.00	1950	Breaker feedback signal wait time

Table 89. Protection G2.4

Code	Parameter	Min	Max	Unit	Default	ID	Description
P2.4.7	ChokeTempFauMode	0	3		1	1951	Response to Choke Temp mode when Temp measurement is using digital input (DI) signals or PT100 signal 0=No action (DI) 1=Warn + Fault (after delay) (DI) 2=Fault (DI) 3=PT100
P2.4.8	ChokeOTFaultDela	0	30	min	5	1952	When choke temp fault mode=1, after this time, warning will be changed to fault
P2.4.9	ChokeOTWarnLevel	-30.0	200.0	deg	110.0	1953	Choke temp using pt100. If temp is over this limit, a warning will generate
P2.4.10	ChokeOTFaultLeve	-30.0	200.0	deg	130.0	1954	Choke temp using pt100. If temp is over this limit, a fault will generate
P2.4.11	Ext Fault Mode	0	4		0	1955	External fault mode selection 0=No action 1=Warnng + Fault(after delay) 2=Fault 3=Inv Warning+ Fault(after delay) 4=Inv Fault
P2.4.12	Ext Fault Delay	0	600	min	0	1956	The Delay Time for triggering an external fault after an external warning is active.
P2.4.13	CoolingFaultMode	0	4		0	1957	Fault mode selection for liquid cooling fault from digital input signal 0= No action 1= Warning + Fault(after delayed) 2= Fault 3= Inv Warning + Fault (after delay) 4= Inv Fault
P2.4.14	CoolingFaultDela	0	3600	s	1	1958	A delay time for triggering a liquid fault after liquid warning is active
P2.4.15	E Stop Mode	0	4		0	1959	E stop mode selection 0=No action 1=Warning, ditial input goes to TRUE 2=Fault, digital input goes to TRUE 3=Inv Warning, digital input goes to FALSE 4=Inv Fault, digital input goes to FALSE

Table 90. Fieldbus G2.5

Code	Parameter	Min	Max	Unit	Default	ID	Description
P2.5.1	Process Data IN1	0	10000		0	876	
P2.5.2	Process Data IN2	0	10000		0	877	
P2.5.3	Process Data IN3	0	10000		0	878	
P2.5.4	Process Data IN4	0	10000		0	879	
P2.5.5	Process Data IN5	0	10000		0	880	
P2.5.6	Process Data IN6	0	10000		0	881	
P2.5.7	Process Data IN7	0	10000		0	882	
P2.5.8	Process Data IN8	0	10000		0	883	
P2.5.9	ProcessData Out1	0	10000		0	852	
P2.5.10	ProcessData Out2	0	10000		0	853	
P2.5.11	ProcessData Out3	0	10000		0	854	
P2.5.12	ProcessData Out4	0	10000		0	855	
P2.5.13	ProcessData Out5	0	10000		0	856	
P2.5.14	ProcessData Out6	0	10000		0	857	
P2.5.15	ProcessData Out7	0	10000		0	858	
P2.5.16	ProcessData Out8	0	10000		0	859	

Table 91. Advanced par G2.6

Code	Parameter	Min	Max	Unit	Default	ID	Description
P2.6.1	OT Alarm Level	-30.0	55.0	deg	55.0	1961	If CH62 PT100 sensor is over this level, alarm will generated
P2.6.2	Fan Type	1	2		2	1962	Cooling fan type selection 1=fan sensor is status sinal, if signal is low, fault will generate 2=also status signal, fan sensor signal is inverted, if signal is high, fault will generate
P2.6.3	Run Start	0	1		0	1963	Start mode selection 0=Rising Edge, run command need rising edge to restart the system 1=Auto Start, run command active, system will auto restart

Table 92. OPT-BH parameters G7.3

Code	Parameter	Min	Max	Unit	Default	ID	Description
7.3.1.1	Sensor 1 type	0	6		0		0=No Sensor 1=PT100 2=PT1000 3=Ni1000 4=KTY84 5=2 x PT100 6=3 x PT100
7.3.1.2	Sensor 2 type	0	6		0		See above
7.3.1.3	Sensor 3 type	0	6		0		See above

NFE's internal temperature sensor is PT100. Set 7.3.1.1 = 1.

11.14 CH60 LIQUID-COOLED NFE PROTECTIONS

The protections for software version ANCNQ100 are described below.

Table 93. Voltage protections

Main voltage P2.1.1	$400V_{AC} \leq P2.1.1 \leq 500V_{AC}$	$500V_{AC} < P2.1.1 \leq 690V_{AC}$
Under voltage trip	333V _{DC}	573V _{DC}
Under voltage alarm	371V _{DC}	633V _{DC}
Over voltage alarm	830V _{DC}	1150V _{DC}
Over voltage trip	911V _{DC}	1250V _{DC}

Table 94. Unit temperature protections

Unit temperature	V1.2.3
Under temp. trip	-10°C
Over temp. alarm (*1)	55°C
Over temp. trip	60°C

(*1) Temperature level may be changed by a parameter

Table 95. Choke temperature protections

Choke temperature	V1.2.4 & V1.2.5
Over temp. alarm (*2)	110°C
Over temp. trip (*2)	130°C

(*2) Chokes require PT100 sensors. Temperature levels may be changed by parameters

11.15 FAULT CODES

When a fault is detected by the NFE control electronics, the drive is **stopped** and main circuit breakers and the charging switch is controlled into open state, which will then disconnect the NFE module from the mains supply. The fault can be reset with the Reset button on the control keypad or via the I/O terminal. Resetting the faults will clear the fault and initiate new start-up procedure of the NFE unit. The faults are stored in the Fault history menu (M5) which can be browsed. The different fault codes you will find in the table below.

The fault codes, their causes and correcting actions for software version ANCNQ100 are presented in the table below.

Table 96. Fault codes

Fault code	Fault	Possible cause	Correcting measures
2	Overvoltage	<p>The DC-link voltage has exceeded the limits.</p> <ul style="list-style-type: none"> - too short a deceleration time - high overvoltage spikes in supply <p>Fault:</p> <ul style="list-style-type: none"> - 911Vdc, Main Voltage P2.1.1 400-500Vac - 1250Vdc, Main Voltage P2.1.1 500-690Vac <p>Warning:</p> <ul style="list-style-type: none"> - 860vdc, Main Voltage P2.1.1 400-500Vac - 1150Vdc, Main Voltage P2.1.1 500-690Vac 	<ul style="list-style-type: none"> • Set deceleration time longer. • Use brake chopper or brake resistor (available as options). • Set over voltage control active with INU devices. • Check input voltage.
4	Charging fault	<p>The pre-set charging time (defined by MaxChargeTime parameter P.2.1.3, default 5 sec) has been exceeded. DC voltage must rise above 40VDC in 1 second</p>	<ul style="list-style-type: none"> • Check the external charging circuit & charging resistor dimensioning • Check P.2.1.3 MaxChargeTime
9	UnderVoltage	<p>The DC-link voltage has decreased under the limits defined.</p> <ul style="list-style-type: none"> - Too low supply voltage. - Component failure. - Defect input fuse. - External charge switch not closed. <p>Fault:</p> <ul style="list-style-type: none"> - 333Vdc; Main Voltage P2.1.1 400-500Vac - 573Vdc; Main Voltage P2.1.1 500-690Vac <p>Warning:</p> <ul style="list-style-type: none"> - 371Vdc; Main Voltage P2.1.1 400-500Vac - 633Vdc; Main Voltage P2.1.1 500-690Vac 	<ul style="list-style-type: none"> • If there is a temporary supply voltage break, RESET the fault and RESTART the drive. • Check the supply voltage. If the measured value is sufficient, internal failure has occurred. • Check the electrical network, if any breaks occur. • If the fault re-occurs, contact your local/nearest service center or distributor. Report carefully all the used software, application and all options.

Table 96. Fault codes

Fault code	Fault	Possible cause	Correcting measures
10	Input phase	<p>External electronic monitoring relay have detected undervoltage, phase sequence or phase failure issue.</p> <ul style="list-style-type: none"> • min. threshold value: 360Vac for 400-500Vac supply voltage • min. threshold value: 470Vac for 525-690Vac supply voltage • response delay is set to be 0.1 sec <p>Various causes:</p> <ul style="list-style-type: none"> - Supply phase failure - Supply fuse failure - Incorrect Mains cabling - Grid interruption 	Check EMD relay settings, Signal wiring, supply voltage, fuses, supply cable, rectifying bridge.
13	Undertemperature	Power module heatsink temperature is under $-10\text{ }^{\circ}\text{C}$.	Power module is in a too cold place or coolant agent is too cold. Check the ambient & coolant temperature. Check the signal wiring.
14	Overtemperature	<p>Fault: Power module heatsink temperature is over $60\text{ }^{\circ}\text{C}$.</p> <p>Warning: Power module heatsink temperature is over $55\text{ }^{\circ}\text{C}$.</p>	<ul style="list-style-type: none"> • Check Coolant flow and temperature • Check the ambient temperature. • Check the cooling fan condition • Check the power module loading • Check the signal wiring
32	Fan cooling	<p>Jammed cooling fan</p> <ul style="list-style-type: none"> - Cooling Fan failure - Cooling Fan is not rotating 	<ul style="list-style-type: none"> • Check the signal wiring • Change the cooling fans
51	Ext Fault	External fault digital input have triggered the fault	<ul style="list-style-type: none"> • Check the signal wiring • Check External Fault input
56	Choke Temp	<p>Over temperature switch feedback or</p> <p>Fault: The temperature of the external input AC choke is over $130\text{ }^{\circ}\text{C}$ (measured from PT100 thermistor).</p> <p>Warning: The temperature of the external input AC choke is over $110\text{ }^{\circ}\text{C}$. (measured from PT100 thermistor)</p>	<ul style="list-style-type: none"> • Check input AC choke cooling conditions • Check the power module loading • Check the signal wiring

Table 96. Fault codes

Fault code	Fault	Possible cause	Correcting measures
60	Cooling	Cooling OK digital input for liquid cooling feedback have triggered the fault	<ul style="list-style-type: none"> • Check liquid cooling • Check the signal wiring • Check Cooling OK input
63	EmergencyStop	E-stop digital input for emergency stop feedback have triggered the fault	<ul style="list-style-type: none"> • Check Main Circuit Breaker functionality • Check signal wiring
64	Breaker Trip	MCBs Feedback signal missing after settled time defined with parameter Breaker Ack Time P2.4.6.	<ul style="list-style-type: none"> • Check Main Circuit Breaker functionality • Check signal wiring

12. BRAKE CHOPPER UNIT (NXB)

12.1 INTRODUCTION

The VACON® NXB (Brake chopper unit) is a unidirectional power converter for the supply of excessive energy from a common DC bus drive line-up to resistors where the energy is dissipated as heat. External resistors are needed. The NXB improves the DC-link voltage controllability as well as enhances the motor drives performance in dynamic applications.

Mechanically, the NXB module is based on inverter unit construction. The dynamic DC energy brake function is achieved through a specific NXB system software. Several NXB modules can be installed parallelly in order to increase the braking capacity, however, the modules require mutual synchronization.

12.2 TYPE DESIGNATION CODE

In Vacon type designation code, the Brake Chopper Unit is characterized by number 8, for example:

NXB	0300	5	A	0	T	0	8WF	A1A2000000
------------	------	---	---	---	---	---	------------	------------

12.3 DIAGRAMS

12.3.1 NXB BRAKE CHOPPER UNIT BLOCK DIAGRAM

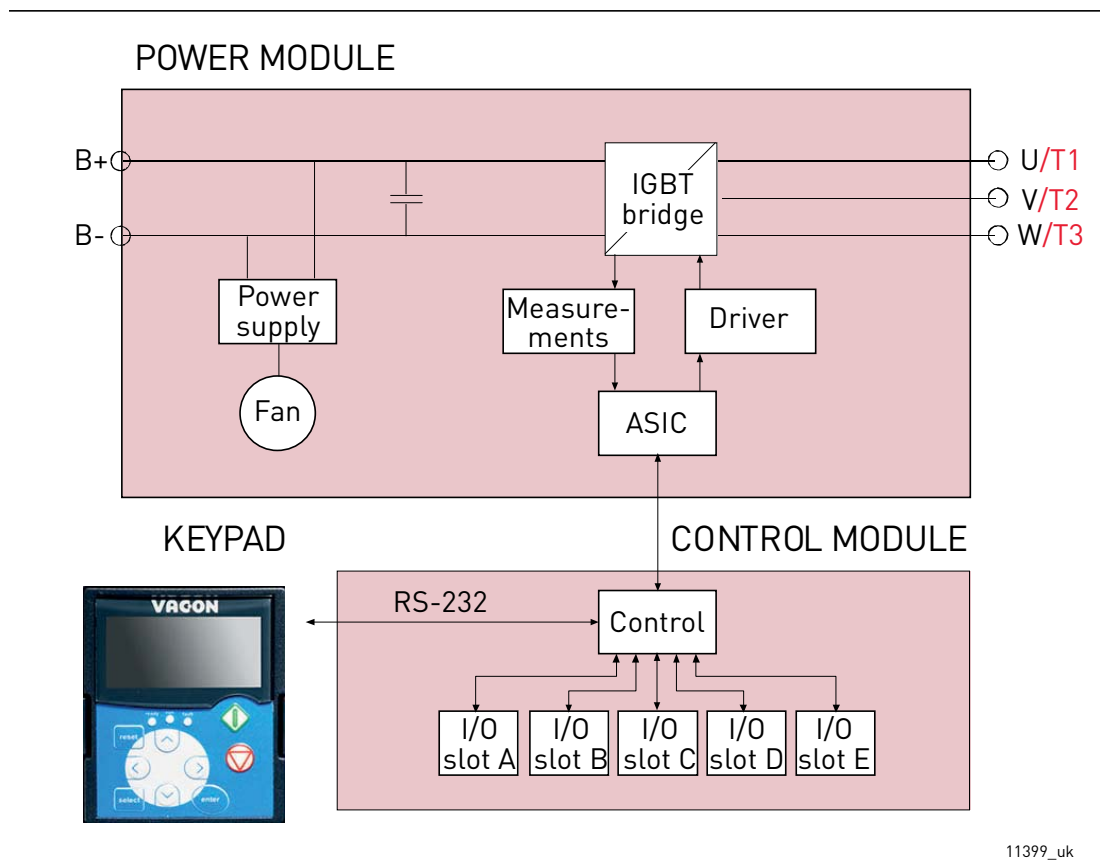
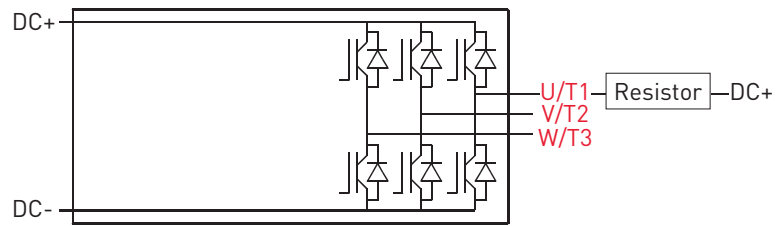

Figure 106. BCU block diagram

12.3.2 VACON® NXB TOPOLOGIES AND CONNECTION

NXB (Brake Chopper Unit) + one resistor is a braking power control unit. Unnecessary energy is burnt off



NXB (Brake Chopper Unit) + two resistors is a braking power control unit. Unnecessary energy is burnt off

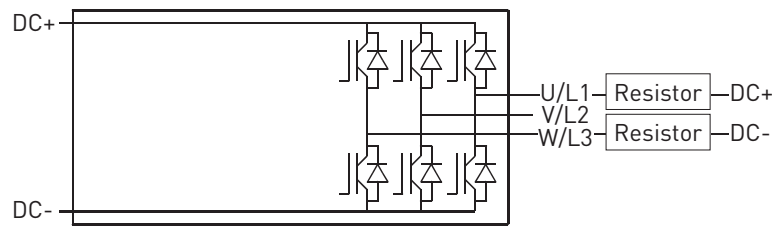

11403_uk

Figure 107. Brake chopper unit topology

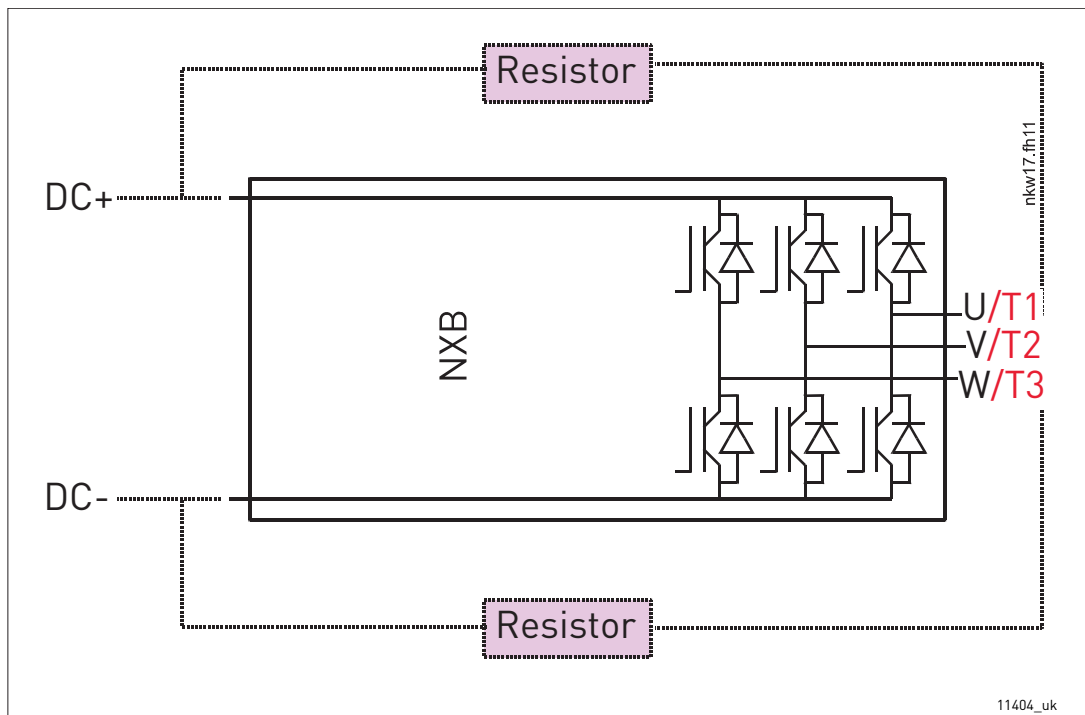

11404_uk

Figure 108. VACON® Brake Chopper Unit connections

12.4 BRAKE CHOPPER UNIT TECHNICAL DATA

*) NX_8 AC drives only available as Ch6x AFE/BCU/INU units.

Table 97. Technical specification for VACON® NXB Liquid-Cooled brake chopper unit

Supply connection	Input voltage U_{in}	NX_5: 400...500 VAC (-10%...+10%); 465...800 VDC (-0%...+0%) NX_6: 525...690 VAC (-10%...+10%); 640...1100 VDC (-0%...+0%) NX_8: 525...690 VAC (-10%...+10%); 640...1136 VDC (-0%...+0%)*
	Input current	DC $I_{in} \sim I_{out}$
	DC bank capacitance	Voltage class 500 V: Ch3 (16-31A units): 600 μ F Ch3 (38-61A units): 2400 μ F CH4: 2400 μ F CH5: 7200 μ F CH61: 10800 μ F CH62: 10800 μ F Voltage class 690 V: CH61: 4800 μ F CH62: 4800 μ F
	Starting delay	2...5 s
Resistor connection	Output voltage	$U_{in} \sim U_{out}$
	Continuous output current	I_{br} : Max ambient temperature +50 °C
	Connection order	R1 U – DC+ R2 W – DC-
Control characteristics	Control method	Voltage level control, default $U_n+18\%$
	Parallel BCU	Requires synchronization
Ambient conditions	Ambient operating temperature	-10 °C (no frost)...+50 °C (at I_{th}) The VACON® NX Liquid-Cooled drives must be used in a heated indoor controlled environment
	Installation temperature	0...+70 °C
	Storage temperature	-40 °C...+70 °C; No liquid in heatsink under 0 °C
	Relative humidity	5 to 96% RH, non-condensing, no dripping water
	Air quality: - chemical vapours - mechanical particles	IEC 721-3-3, unit in operation, class 3C2 IEC 721-3-3, unit in operation, class 3S2 • No conductive dust allowed • No corrosive gases
	Altitude	NX_5 (380...500 V): max. 3000 m (in case network is not corner grounded) NX_6: max. 2000 m. For further requirements, contact factory 100-% load capacity (no derating) up to 1,000 m; above 1,000 m derating of maximum ambient operating temperature by 0.5 °C per each 100 m is required.

Table 97. Technical specification for VACON® NXB Liquid-Cooled brake chopper unit

	Vibration EN 50178/EN 60068-2-6	5...150 Hz Displacement amplitude 0.25 mm (peak) at 3...31 Hz Max acceleration amplitude 1 G at 31...150 Hz
	Shock EN 50178, EN 60068-2-27	UPS Drop Test (for applicable UPS weights) Storage and shipping: max 15 G, 11 ms (in package)
	Cooling capacity required	See Table 15.
	Unit enclosure class	IP00/Open Frame standard in entire kW/HP range
	Pollution degree	PD2
EMC	Immunity	Fulfills IEC/EN 61800-3 EMC immunity requirements
Safety		CE, UL, IEC/EN 61800-5-1 (2007) (see unit nameplate for more detailed approvals) IEC 60664-1 and UL840 in overvoltage category III.
Control connections	Analogue input voltage	0...+10 V, Ri = 200 kW, (-10 V...+10 V joystick control) Resolution 0.1%, accuracy ±1%
	Analogue input current	0(4)...20 mA, Ri = 250 W differential
	Digital inputs (6)	Positive or negative logic; 18...30 VDC
	Auxiliary voltage	+24 V, ±10%, max. 250 mA
	Output reference voltage	+10 V, +3%, max. load 10 mA
	Analogue output	0(4)...20 mA; RL max. 500 W; Resolution 10 bit; Accuracy ±2%
	Digital outputs	Open collector output, 50 mA/48 V
	Relay outputs	2 programmable change-over relay outputs Switching capacity: 24 VDC/8 A, 250 VAC/8 A, 125 VDC/0.4 A Min. switching load: 5 V/10 mA
Protections	Overvoltage trip limit	NX_5: 911 VDC NX_6: (CH61, CH62, CH63 & CH64): 1258 VDC NX_6: (Other chassis): 1200 VDC NX_8: (CH61, CH62, CH63 & CH64): 1300 VDC
	Undervoltage trip limit	NX_5: 333 VDC; NX_6: 461 VDC; NX_8: 461 VDC (all VDC)
	Overcurrent protection	Yes
	Unit overtemperature protection	Yes
	Resistor overtemperature protection	Yes
	Wrong connection protection	Yes
	Short-circuit protection of +24 V and +10 V reference voltages	Yes

Table 97. Technical specification for VACON® NXB Liquid-Cooled brake chopper unit

Liquid cooling	Allowed cooling agents	Drinking water (see specification on page 46) Water-glycol mixture See derating specifications, Chapter 5.3.
	Volume	See Table 19.
	Temperature of cooling agent	0...35 °C input (Ibr); 35...55 °C: derating required, see Chapter 5.3 . Max. temperature rise during circulation 5 °C No condensation allowed. See Chapter 5.2.1.
	Cooling agent flow rates	See Table 15.
	System max. working pressure	6 bar
	System max. peak pressure	30 bar
	Pressure loss (at nominal flow)	Varies according to size. See Table 17 .

12.5 BCU POWER RATINGS

12.5.1 VACON® NXB; DC VOLTAGE 460–800 V

Table 98. Power ratings of VACON® NXB, supply voltage 460–800 Vdc

Braking voltage 460-800 VDC							
NXB type	Loadability				Braking capacity		Chassis
	BCU rated cont. braking current, I_{br} [A]	Rated min resistance at 800 VDC [Ω]	Rated min resistance at 600 VDC [Ω]	Rated max input current [Adc]	Rated cont. braking power 2*R at 800 VDC [kW]*	Rated cont. braking power 2*R at 600 VDC [kW]**	
NXB_0031 5	2*31	25.7	19.5	62	49	37	CH3
NXB_0061 5	2*61	13.1	9.9	122	97	73	CH3
NXB_0087 5	2*87	9.2	7.0	174	138	105	CH4
NXB_0105 5	2*105	7.6	5.8	210	167	127	CH4
NXB_0140 5	2*140	5.7	4.3	280	223	169	CH4
NXB_0168 5	2*168	4.7	3.6	336	267	203	CH5
NXB_0205 5	2*205	3.9	3.0	410	326	248	CH5
NXB_0261 5	2*261	3.1	2.3	522	415	316	CH5
NXB_0300 5	2*300	2.7	2.0	600	477	363	CH61
NXB_0385 5	2*385	2.1	1.6	770	613	466	CH61
NXB_0460 5	2*460	1.7	1.3	920	732	556	CH62
NXB_0520 5	2*520	1.5	1.2	1040	828	629	CH62
NXB_0590 5	2*590	1.4	1.1	1180	939	714	CH62
NXB_0650 5	2*650	1.2	1.0	1300	1035	786	CH62
NXB_0730 5	2*730	1.1	0.9	1460	1162	833	CH62

*. 800 VDC equals U_{brake} at 500 VAC

** . 600 VDC equals U_{brake} at 380 VAC

For dimensions of BCU units, see Table 14.

NOTE! The rated currents in given ambient (+50 °C) and coolant (+30°) temperatures are achieved only when the switching frequency is equal to or less than the factory default.

NOTE! Braking power: $P_{brake} = 2 \cdot U_{brake}^2 / R_{brake}$

NOTE! Max input DC current: $I_{in_max} = P_{brake_max} / U_{brake}$

12.5.2 VACON® NXB; DC VOLTAGE 640–1100 V

Table 99. Power ratings of VACON® NXB, supply voltage 640–1100 Vdc

Braking voltage 640-1100 VDC ***)							
NXB type	Loadability				Braking capacity		Chassis
	BCU rated cont. braking current, I_{br} [A]	Rated min resistance at 1100 VDC [Ω]	Rated min resistance at 840 VDC [Ω]	Rated max input current [Adc]	Rated cont. braking power 2*R at 1100 VDC [kW]*	Rated cont. braking power 2*R at 840 VDC [kW]**	
NXB_0170 6	2*170	6.5	4.9	340	372	282	CH61
NXB_0208 6	2*208	5.3	4.0	416	456	346	CH61
NXB_0261 6	2*261	4.2	3.2	522	572	435	CH61
NXB_0325 6	2*325	3.4	2.6	650	713	542	CH62
NXB_0385 6	2*385	2.9	2.2	770	845	643	CH62
NXB_0416 6	2*416	2.6	2.0	832	913	693	CH62
NXB_0460 6	2*460	2.4	1.8	920	1010	767	CH62
NXB_0502 6	2*502	2.2	1.7	1004	1100	838	CH62

*. 1100 VDC equals U_{brake} at 690 VAC

** . 840 VDC equals U_{brake} at 525 VAC

***) Mains voltage 640-1136 VDC for NX_8 inverter units.

For dimensions of BCU units, see Table 10.

NOTE! The rated currents in given ambient (+50 °C) and coolant (+30°) temperatures are achieved only when the switching frequency is equal to or less than the factory default.

NOTE! Braking power: $P_{brake} = 2 \cdot U_{brake}^2 / R_{resistor}$ when 2 resistors are used

NOTE! Max input DC current: $I_{in_max} = P_{brake_max} / U_{brake}$

12.6 VACON® BRAKE RESISTORS AND BRAKE CHOPPER DIMENSIONING

12.6.1 BRAKING ENERGY AND LOSSES

Table 100. VACON® standard brake resistors and NXB energy, mains voltage 465–800 Vdc

Mains voltage 465-800 VDC					
BCU type	BCU output			BCU Power loss at full braking	Chassis
	Resistor	Brake energy			
	Resistor type & R[Ω]	Light duty 5 sec (kJ)	High Duty 10 sec (kJ)	c/a/T* ¹ [kW]	
NXB 0031 5	BRR0031 / 63	82	220	0.7/0.2/0.9	CH3
NXB 0061 5	BRR0061 / 14	254	660	1.3/0.3/1.5	CH3
NXB 0087 5	BRR0061 / 14	254	660	1.5/0.3/1.8	CH4
NXB 0105 5	BRR0105 / 6.5	546	1420	1.8/0.3/2.1	CH4
NXB 0140 5	BRR0105 / 6.5	546	1420	2.3/0.3/2.6	CH4
NXB 0168 5	BRR0105 / 6.5	546	1420	2.5/0.3/2.8	CH5
NXB 0205 5	BRR0105 / 6.5	546	1420	3.0/0.4/3.4	CH5
NXB 0261 5	BRR0105 / 6.5	546	1420	4.0/0.4/4.4	CH5
NXB 0300 5	BRR0300 / 3.3	1094	2842	4.5/0.4/4.9	CH61
NXB 0385 5	BRR0300 / 3.3	1094	2842	5.5/0.5/6.0	CH61
NXB 0460 5	BRR0300 / 3.3	1094	2842	5.5/0.5/6.0	CH62
NXB 0520 5	BRR0520 / 1.4	2520	6600	6.5/0.5/7.0	CH62
NXB 0590 5	BRR0520 / 1.4	2520	6600	7.5/0.6/8.1	CH62
NXB 0650 5	BRR0520 / 1.4	2520	6600	8.5/0.6/9.1	CH62
NXB 0730 5	BRR0730 / 0.9	3950	10264	10.0/0.7/10.7	CH62

Table 101. VACON® standard brake resistors and NXB energy, mains voltage 640–1100 Vdc

Mains voltage 640-1100 VDC					
BCU type	BCU output			BCU Power loss at full braking	Chassis
	Resistor	Brake energy			
	Resistor type & R[Ω]	Light Duty 5 sec (kJ)	High Duty 10 sec (kJ)	c/a/T* [kW]	
NXB 0170_6	BRR0208 / 7	968	2516	3.6/0.2/3.8	Ch61
NXB 0208_6	BRR0208 / 7	968	2516	4.3/0.3/4.6	Ch61
NXB 0261_6	BRR0208 / 7	968	2516	5.4/0.3/5.7	Ch61
NXB 0325_6	BRR0208 / 7	968	2516	6.5/0.3/6.8	Ch62
NXB 0385_6	BRR0208 / 7	968	2516	7.5/0.4/7.9	Ch62
NXB 0416_6	BRR0416 / 2.5	2710	7046	8.0/0.4/8.4	Ch62

Table 101. VACON® standard brake resistors and NXB energy, mains voltage 640–1100 Vdc

Mains voltage 640–1100 VDC					
NXB 0460_6	BRR0416 / 2.5	2710	7046	8.7/0.4/9.1	Ch62
NXB 0502_6	BRR0416 / 1.7	3986	10362	9.8/0.5/10.3	Ch62

*. c = power loss into coolant; a = power loss into air; T = total power loss; power losses of input chokes not included. All power losses obtained using max. supply voltage and switching frequency of 3.6 kHz and Closed-Loop control mode. All power losses are worst case losses.

Heavy duty braking: 3 s 100%, followed by 7 s decreasing to zero

Light duty braking: 5 s 100%

NOTE! The rated currents in given ambient (+50 °C) and coolant (+30°) temperatures are achieved only when the switching frequency is equal to or less than the factory default.

NOTE! Braking power: $P_{\text{brake}} = 2 \cdot U_{\text{brake}}^2 / R_{\text{resistor}}$ when 2 resistors are used

NOTE! Max input DC current: $I_{\text{in_max}} = P_{\text{brake_max}} / U_{\text{brake}}$

12.6.2 BRAKING POWER AND RESISTANCE, MAINS VOLTAGE 380–500 VAC/600–800 VDC

Table 102. Voltage levels

Voltage	Default +18% DC-link voltage level for braking							
	Vac	380	400	420	440	460	480	500
	Vdc	513	540	567	594	621	648	675
	U _{br} +18%	605	637	669	701	733	765	797

Table 103. Maximum braking power

Chas-sis	NXB unit	Thermal current [I _{th}]	Max braking power at DC-link voltages [kW]						
			605	637	669	701	733	765	797
Ch3	NXB 0031_5	31	37.5	39.5	41.5	43.5	45.4	47.4	49.4
Ch3	NXB 0061_5	61	73.9	77.7	81.6	85.5	89.4	93.3	97.2
Ch4	NXB 0087_5	87	105.3	110.9	116.4	122.0	127.5	133.0	138.6
Ch4	NXB 0105_5	105	127.1	133.8	140.5	147.2	153.9	160.6	167.3
Ch4	NXB 0140_5	140	169.5	178.4	187.3	196.3	205.2	214.1	223.0
Ch5	NXB 0168_5	168	203.4	214.1	224.8	235.5	246.2	256.9	267.6
Ch5	NXB 0205_5	205	248.2	261.3	274.3	287.4	300.4	313.5	326.6
Ch5	NXB 0261_5	261	316.0	332.6	349.2	365.9	382.5	399.1	415.8
Ch61	NXB 0300_5	300	363.2	382.3	401.4	420.6	439.7	458.8	477.9
Ch61	NXB 0385_5	385	466.1	490.6	515.2	539.7	564.2	588.8	613.3
Ch62	NXB 0460_5	460	556.9	586.2	615.5	644.8	674.2	703.5	732.8
Ch62	NXB 0520_5	520	629.6	662.7	695.8	729.0	762.1	795.2	828.4
Ch62	NXB 0590_5	590	714.3	751.9	789.5	827.1	864.7	902.3	939.9
Ch62	NXB 0650_5	650	786.9	828.4	869.8	911.2	952.6	994.0	1035.5
Ch62	NXB 0730_5	730	883.8	930.3	976.8	1023.3	1069.9	1116.4	1162.9

NOTE! The braking powers indicated in Table 103 can only be achieved with minimum resistance.

Table 104. Minimum resistance

Chassis	NXB unit	Thermal current [I _{th}]	Minimum resistance at DC-link voltages [ohm]						
			605	637	669	701	733	765	797
Ch3	NXB 0031_5	31	19.5	20.6	21.6	22.6	23.6	24.7	25.7
Ch3	NXB 0061_5	61	9.9	10.4	11.0	11.5	12.0	12.5	13.1
Ch4	NXB 0087_5	87	7.0	7.3	7.7	8.1	8.4	8.8	9.2
Ch4	NXB 0105_5	105	5.8	6.1	6.4	6.7	7.0	7.3	7.6
Ch4	NXB 0140_5	140	4.3	4.6	4.8	5.0	5.2	5.5	5.7
Ch5	NXB 0168_5	168	3.6	3.8	4.0	4.2	4.4	4.6	4.7
Ch5	NXB 0205_5	205	3.0	3.1	3.3	3.4	3.6	3.7	3.9

Table 104. Minimum resistance

Chassis	NXB unit	Thermal current [Ith]	Minimum resistance at DC-link voltages [ohm]						
			605	637	669	701	733	765	797
Ch5	NXB 0261_5	261	2.3	2.4	2.6	2.7	2.8	2.9	3.1
Ch61	NXB 0300_5	300	2.0	2.1	2.2	2.3	2.4	2.5	2.7
Ch61	NXB 0385_5	385	1.6	1.7	1.7	1.8	1.9	2.0	2.1
Ch62	NXB 0460_5	460	1.3	1.4	1.5	1.5	1.6	1.7	1.7
Ch62	NXB 0520_5	520	1.2	1.2	1.3	1.3	1.4	1.5	1.5
Ch62	NXB 0590_5	590	1.0	1.1	1.1	1.2	1.2	1.3	1.4
Ch62	NXB 0650_5	650	0.9	1.0	1.0	1.1	1.1	1.2	1.2
Ch62	NXB 0730_5	730	0.8	0.9	0.9	1.0	1.0	1.0	1.1

Table 105. Maximum resistance

Chassis	NXB unit	Thermal current [Ith]	Maximum resistance at DC-link voltages [ohm]						
			605	637	669	701	733	765	797
Ch3	NXB 0031_5	31	97.6	102.8	107.9	113.1	118.2	123.3	128.5
Ch3	NXB 0061_5	61	49.6	52.2	54.8	57.5	60.1	62.7	65.3
Ch4	NXB 0087_5	87	34.8	36.6	38.5	40.3	42.1	43.9	45.8
Ch4	NXB 0105_5	105	28.8	30.3	31.9	33.4	34.9	36.4	37.9
Ch4	NXB 0140_5	140	21.6	22.8	23.9	25.0	26.2	27.3	28.4
Ch5	NXB 0168_5	168	18.0	19.0	19.9	20.9	21.8	22.8	23.7
Ch5	NXB 0205_5	205	14.8	15.5	16.3	17.1	17.9	18.6	19.4
Ch5	NXB 0261_5	261	11.6	12.2	12.8	13.4	14.0	14.6	15.3
Ch61	NXB 0300_5	300	10.1	10.6	11.2	11.7	12.2	12.7	13.3
Ch61	NXB 0385_5	385	7.9	8.3	8.7	9.1	9.5	9.9	10.3
Ch62	NXB 0460_5	460	6.6	6.9	7.3	7.6	8.0	8.3	8.7
Ch62	NXB 0520_5	520	5.8	6.1	6.4	6.7	7.0	7.4	7.7
Ch62	NXB 0590_5	590	5.1	5.4	5.7	5.9	6.2	6.5	6.8
Ch62	NXB 0650_5	650	4.7	4.9	5.1	5.4	5.6	5.9	6.1
Ch62	NXB 0730_5	730	4.1	4.4	4.6	4.8	5.0	5.2	5.5

**12.6.3 BRAKING POWER AND RESISTANCE, MAINS VOLTAGE 525–690 VAC/
840–1100 VDC**

Table 106. Voltage levels

Voltage	Default +18% DC-link voltage level for braking							
	Vac	525	550	575	600	630	660	690
	Vdc	708.8	742.5	776.3	810	850.5	891	931.5
	U _{br} +18%	836	876	916	956	1004	1051	1099

Table 107. Maximum braking power

Chassis	NXB unit	Thermal current [Ith]	Max braking power at DC-link voltages [kW]							
			836	876	916	956	1004	1051	1099	1136 *
Ch61	NXB 0170_6	170	284.4	297.9	311.4	325.0	341.2	357.5	373.7	386.2
Ch61	NXB 0208_6	208	347.9	364.5	381.0	397.6	417.5	437.4	457.3	472.6
Ch62	NXB 0261_6	261	436.6	457.4	478.1	498.9	523.9	548.8	573.8	593.0
Ch62	NXB 0325_6	325	543.6	569.5	595.4	621.3	652.3	683.4	714.5	738.4
Ch62	NXB 0385_6	385	644.0	674.6	705.3	736.0	772.8	809.6	846.4	874.7
Ch62	NXB 0416_6	416	695.8	729.0	762.1	795.2	835.0	874.7	914.5	945.2
Ch62	NXB 0460_6	460	769.4	806.1	842.7	879.3	923.3	967.3	1011.2	1045.1
Ch62	NXB 0502_6	502	839.7	879.7	919.6	959.6	1007.6	1055.6	1103.6	1140.5

NOTE! The braking powers indicated in Table 107 can only be achieved with minimum resistance.

Table 108. Minimum resistance

Chassis	NXB unit	Thermal current [Ith]	Minimum resistance at DC-link voltages [ohm]							
			836	876	916	956	1004	1051	1099	1136 *
Ch61	NXB 0170_6	170	4.9	5.2	5.4	5.6	5.9	6.2	6.5	6.7
Ch61	NXB 0208_6	208	4.0	4.2	4.4	4.6	4.8	5.1	5.3	5.5
Ch62	NXB 0261_6	261	3.2	3.4	3.5	3.7	3.8	4.0	4.2	4.4
Ch62	NXB 0325_6	325	2.6	2.7	2.8	2.9	3.1	3.2	3.4	3.5
Ch62	NXB 0385_6	385	2.2	2.3	2.4	2.5	2.6	2.7	2.9	3.0
Ch62	NXB 0416_6	416	2.0	2.1	2.2	2.3	2.4	2.5	2.6	2.7
Ch62	NXB 0460_6	460	1.8	1.9	2.0	2.1	2.2	2.3	2.4	2.5
Ch62	NXB 0502_6	502	1.7	1.7	1.8	1.9	2.0	2.1	2.2	2.3

Table 109. Maximum resistance

Chassis	NXB unit	Thermal current [Ith]	Maximum resistance at DC-link voltages [ohm]							
			836	876	916	956	1004	1051	1099	1136 *
Ch61	NXB 0170_6	170	24.6	25.8	26.9	28.1	29.5	30.9	32.3	33.4
Ch61	NXB 0208_6	208	20.1	21.1	22.0	23.0	24.1	25.3	26.4	27.3
Ch62	NXB 0261_6	261	16.0	16.8	17.5	18.3	19.2	20.1	21.1	21.8
Ch62	NXB 0325_6	325	12.9	13.5	14.1	14.7	15.4	16.2	16.9	17.5
Ch62	NXB 0385_6	385	10.9	11.4	11.9	12.4	13.0	13.7	14.3	14.8
Ch62	NXB 0416_6	416	10.1	10.5	11.0	11.5	12.1	12.6	13.2	13.7
Ch62	NXB 0460_6	460	9.1	9.5	10.0	10.4	10.9	11.4	11.9	12.3
Ch62	NXB 0502_6	502	8.3	8.7	9.1	9.5	10.0	10.5	10.9	11.3

*. Only valid for NX_8 brake chopper units.

12.7 BRAKE CHOPPER UNIT – FUSE SELECTION

Table 110. BCU fuse selection, mains voltage 465–800 Vdc

Chassis	Type	Min res. value, 2* [ohm]	Brk current	Fuse size*	DIN43620		"TTF" threaded end "7X" or size 83 with end contacts		"TTQF" threaded end size84 or "PLAF" 2x84 with end contacts	
					aR fuse part nr.	Qty. of fuses /dr	aR fuse part nr.	Qty. of fuses/ dr	aR fuse part nr.	Qty. of fuses/ dr
CH3	0016	52.55	32	DIN0	PC70UD13C80PA	2	PC70UD13C63TF	2	-	-
CH3	0022	38.22	44	DIN0	PC70UD13C80PA	2	PC70UD13C80TF	2	-	-
CH3	0031	27.12	62	DIN0	PC70UD13C125PA	2	PC70UD13C125TF	2	-	-
CH3	0038	22.13	76	DIN0	PC70UD13C125PA	2	PC70UD13C125TF	2	-	-
CH3	0045	18.68	90	DIN0	PC70UD13C200PA	2	PC70UD13C200TF	2	-	-
CH3	0061	13.78	122	DIN0	PC70UD13C200PA	2	PC70UD13C200TF	2	-	-
CH4	0072	11.68	144	1	PC71UD13C315PA	2	PC71UD13C315TF	2	-	-
CH4	0087	9.66	174	1	PC71UD13C315PA	2	PC71UD13C315TF	2	-	-
CH4	0105	8.01	210	1	PC71UD13C400PA	2	PC71UD13C400TF	2	-	-
CH4	0140	6.01	280	3	PC73UD13C500PA	2	PC73UD13C500TF	2	-	-
CH5	0168	5.00	336	3	PC73UD13C630PA	2	PC73UD13C630TF	2	-	-
CH5	0205	4.10	410	3	PC73UD11C800PA	2	PC73UD13C800TF	2	-	-
CH5	0261	3.22	522	3	PC73UD90V11CPA	2	PC73UD95V11CTF	2	-	-
CH61	0300	2.80	600	3	PC73UD90V11CPA	2	PC73UD95V11CTF	2	-	-
CH61	0385	2.18	770	3	PC73UD11C800PA	4	PC83UD11C13CTF	2	-	-
CH62	0460	1.83	920	3	PC73UD11C800PA	4	PC73UD13C800TF	4	PC84UD13C15CTQ	2
CH62	0520	1.62	1040	3	PC73UD90V11CPA	4	PC73UD95V11CTF	4	PC84UD12C18CTQ	2
CH62	0590	1.43	1180	3	PC73UD90V11CPA	4	PC73UD95V11CTF	4	PC84UD11C20CTQ	2
CH62	0650	1.29	1300	3	PC73UD90V11CPA	4	PC73UD95V11CTF	4	PC84UD11C22CTQ	2
CH62	0730	1.15	1460		-		PC83UD11C13CTF	4	PC84UD11C24CTQ	2

Table 111. BCU fuse selection, mains voltage 640–1100 Vdc

Chassis	Type	Min res. value, 2* [ohm]	Brk current	Fuse size*	DIN43620		"TTF" threaded end "7X" or size 83 with end contacts		"TTQF" threaded end size84 or "PLAF" 2x84 with end contacts	
					aR fuse part nr.	Qty. of fuses /dr	aR fuse part nr.	Qty. of fuses/ dr	aR fuse part nr.	Qty. of fuses/ dr
CH61	0170	6.51	340	DIN3	PC73UD13C630PA	2	PC73UD13C630TF	2	-	-
CH61	0208	5.32	416	DIN3	PC73UD11C800PA	2	PC73UD13C800TF	2	-	-
CH61	0261	4.24	522	DIN3	PC73UD11C800PA	2	PC73UD13C800TF	2	-	-
CH62	0310	3.41	650	DIN3	PC73UD13C630PA	4	PC83UD12C11CTF	2	-	-
CH62	0385	2.88	770	DIN3	PC73UD13C630PA	4	PC83UD11C13CTF	2	-	-
CH62	0416	2.66	832	DIN3	PC73UD11C800PA	4	PC83UD11C14CTF	2	PC84UD13C15CTQ	2
CH62	0460	2.41	920	DIN3	PC73UD11C800PA	4	PC73UD13C800TF	4	PC84UD13C15CTQ	2
CH62	0502	2.21	1004	DIN3	PC73UD11C800PA	4	PC73UD13C800TF	4	PC84UD13C15CTQ	2

13. APPENDICES

Appendix 1

VACON® NX Liquid-Cooled AC drive and inverter main circuit and control diagrams

CH3, FC

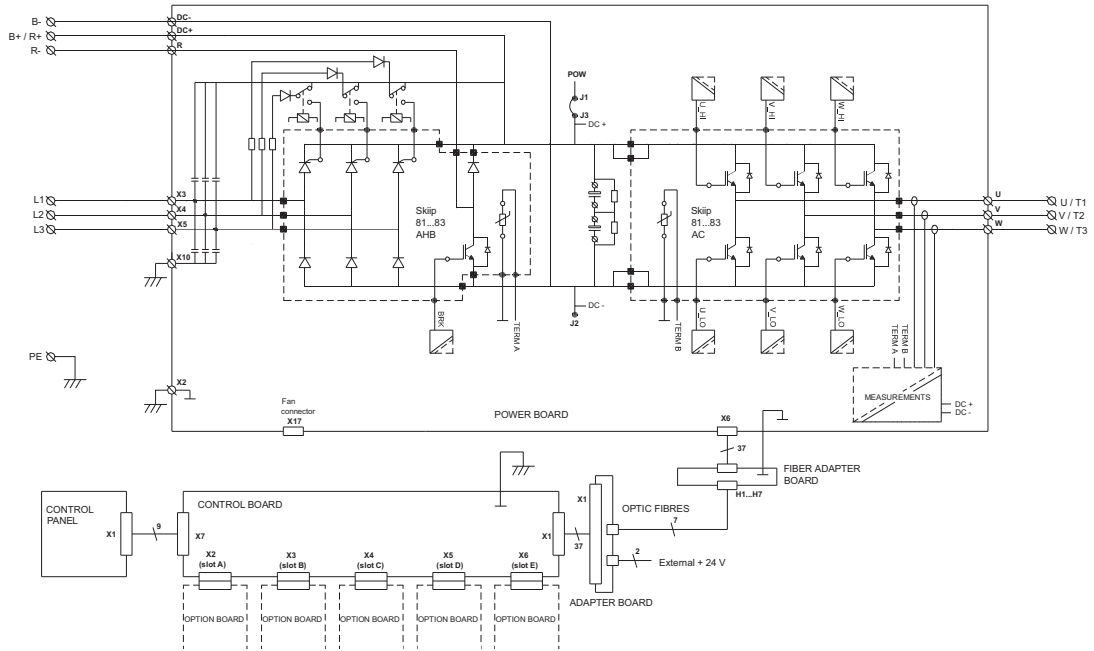

11405_uk

CH4, FC

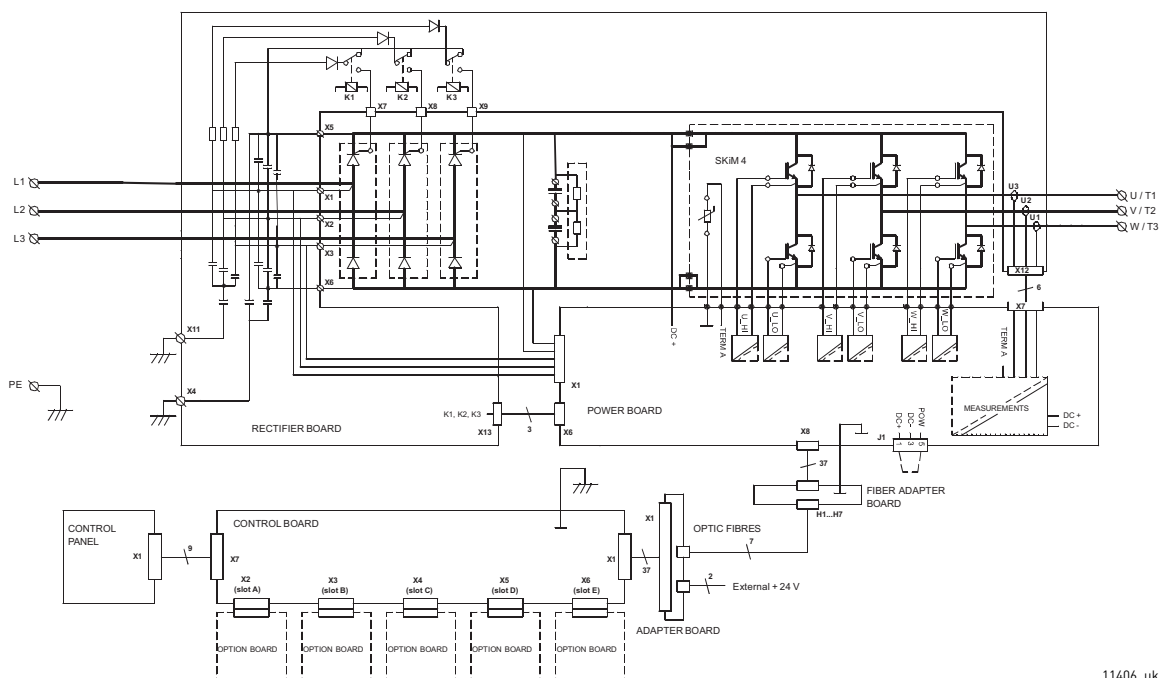

11406_uk

CH5, FC

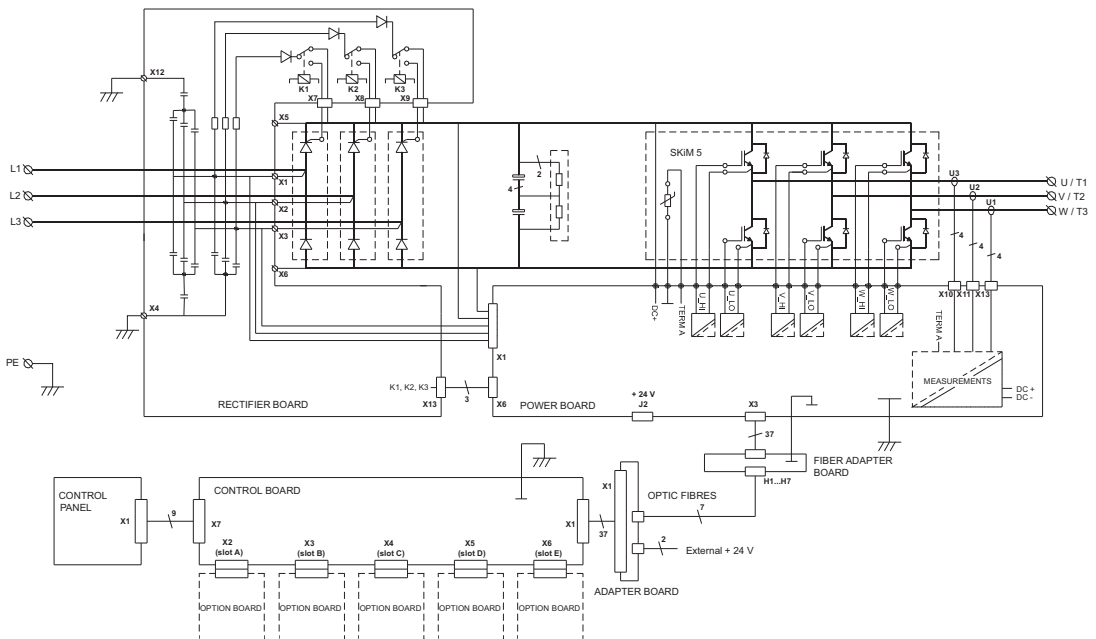

11407_uk

L/C NFE

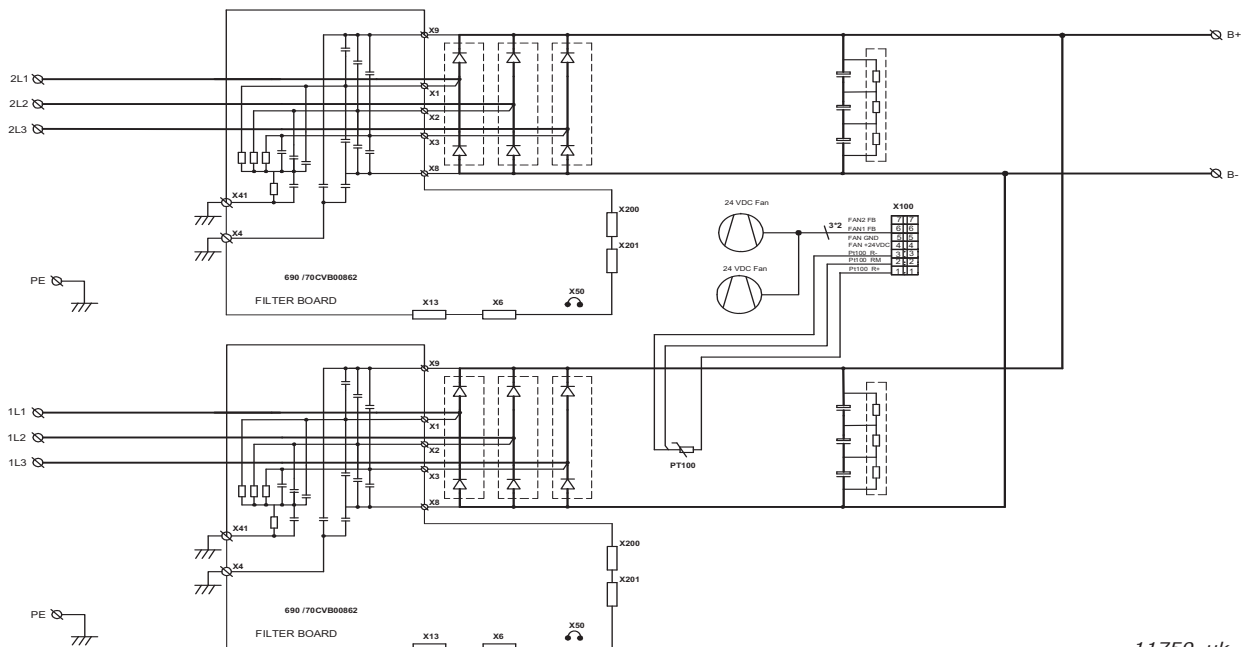

11750_uk

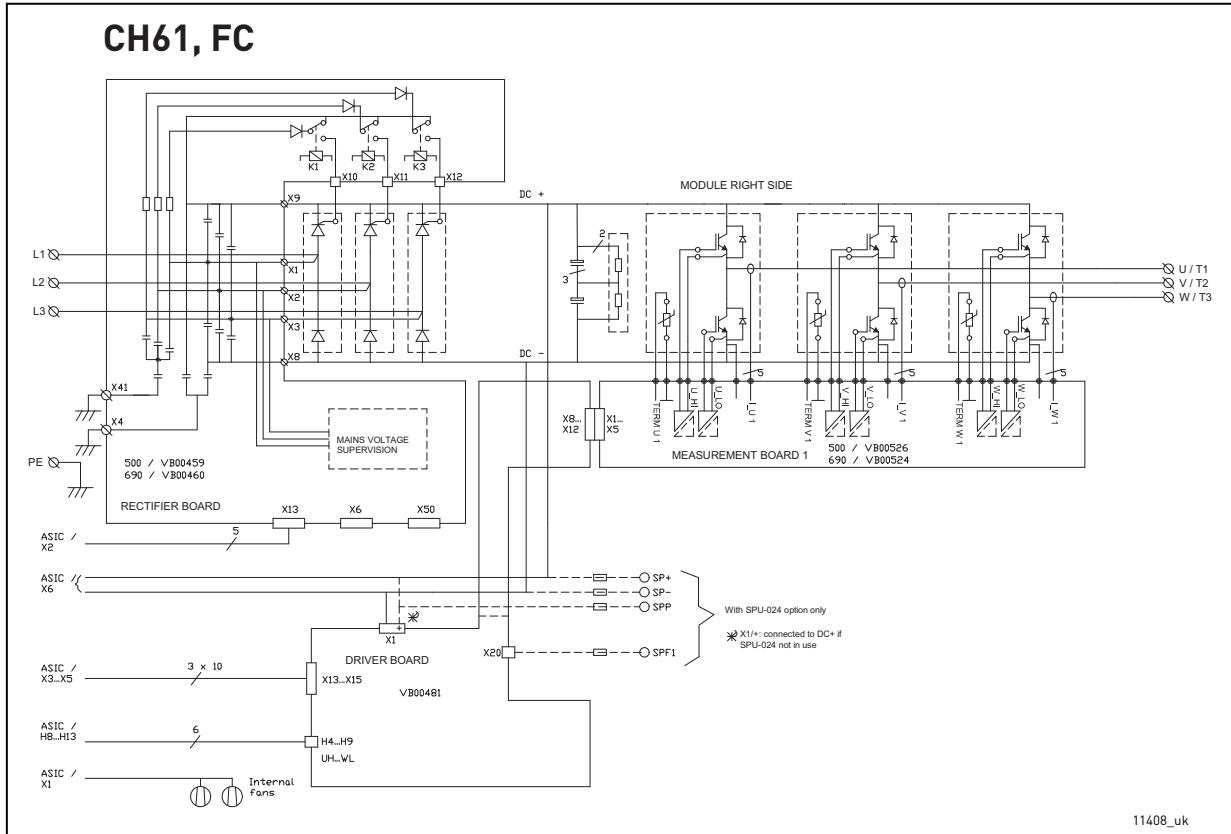

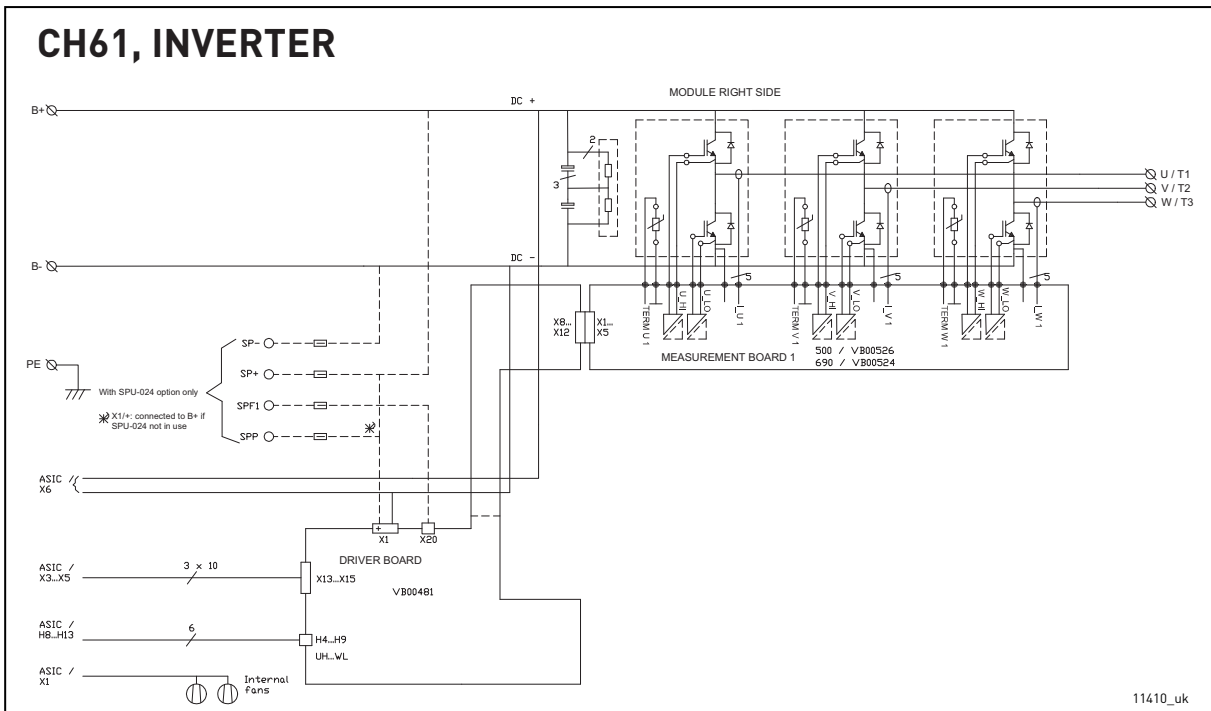
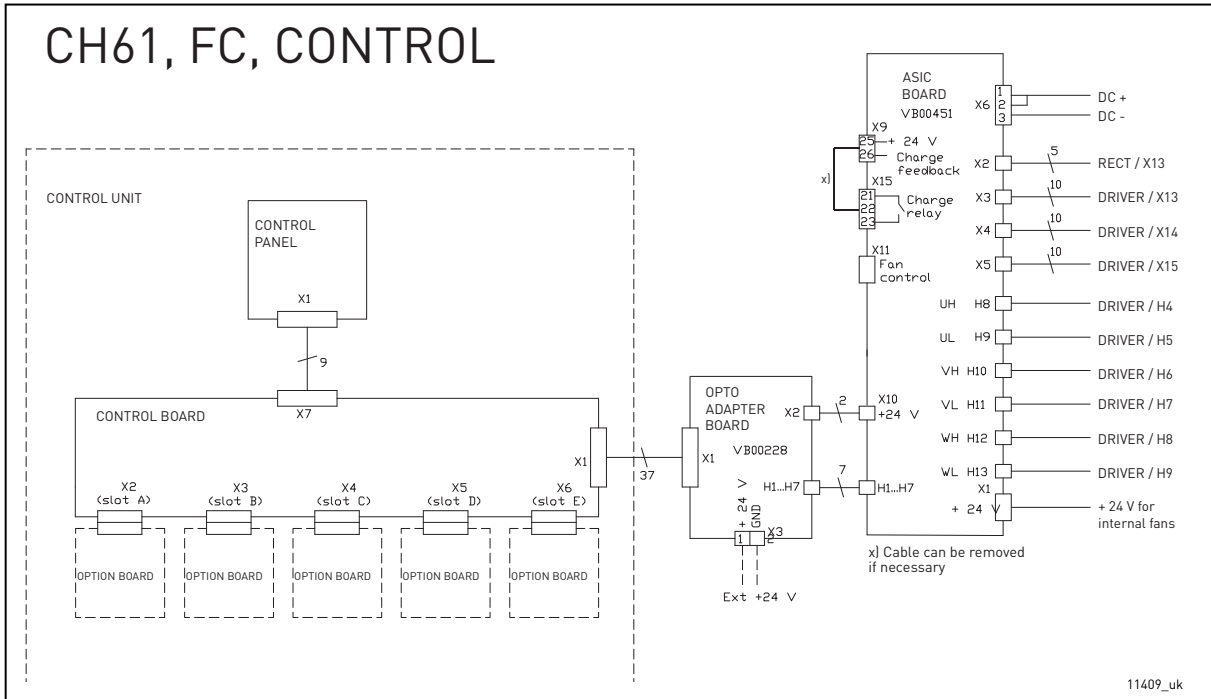

CH61, INVERTER, CONTROL

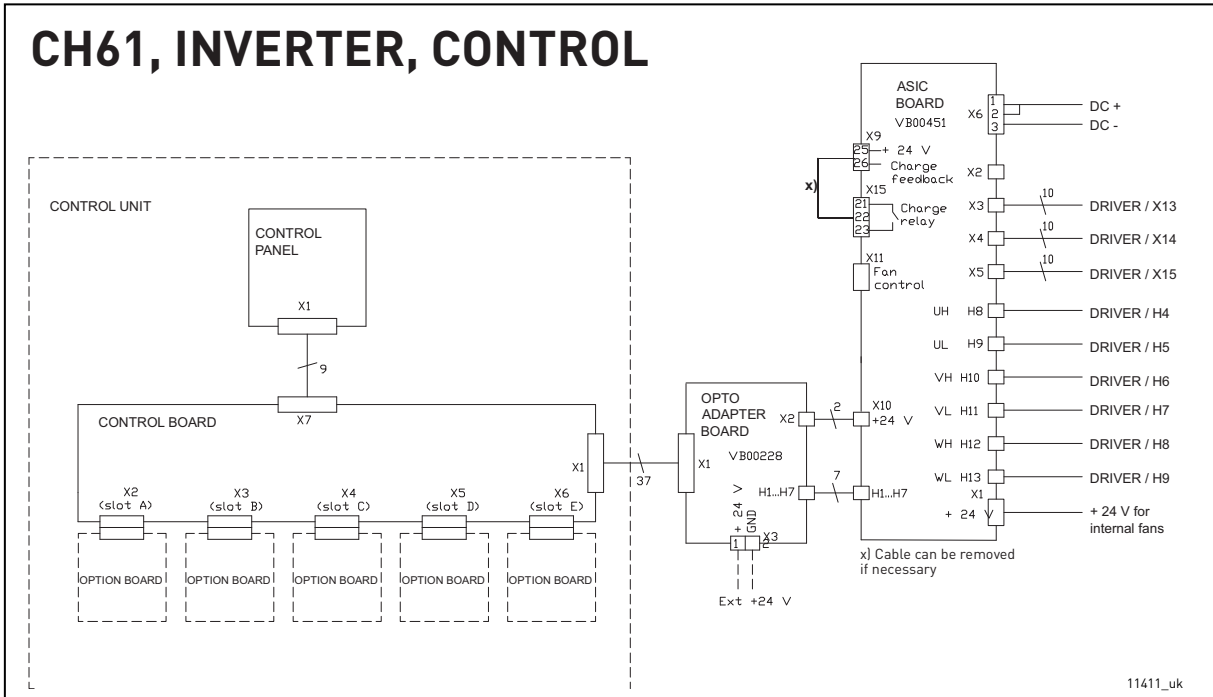

CH62, INVERTER

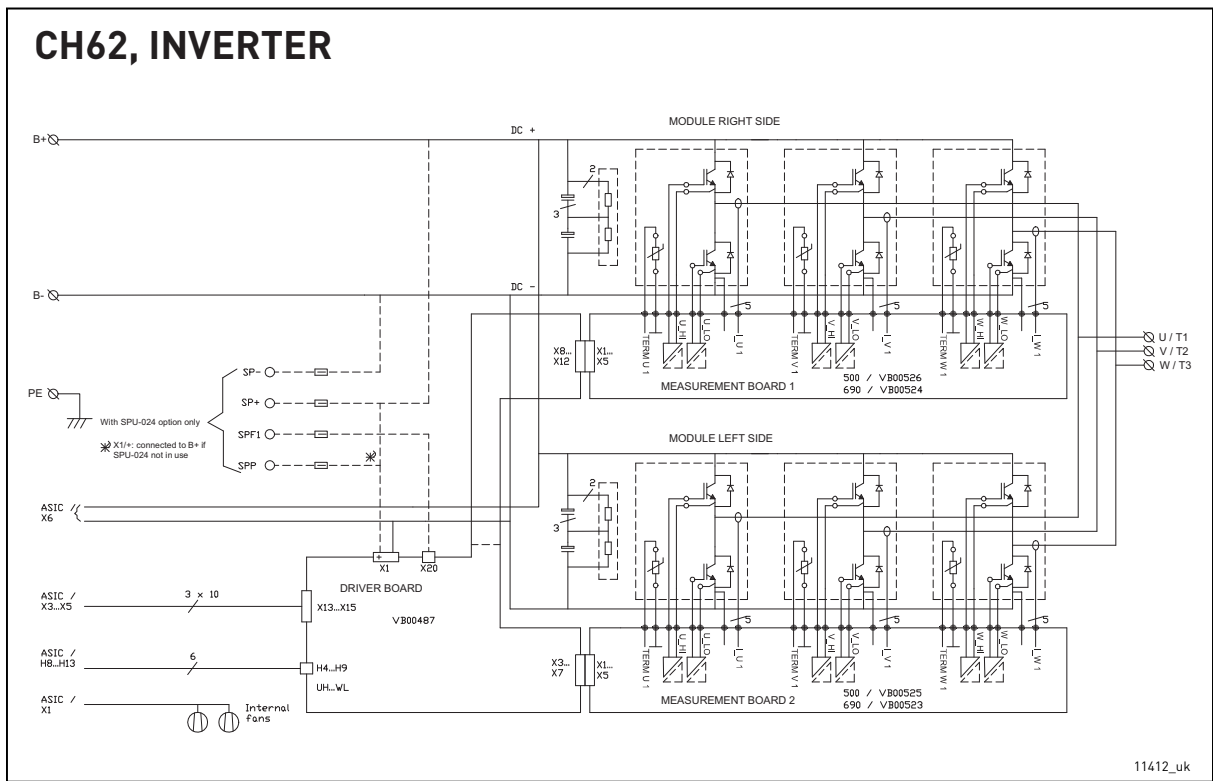

CH62, INVERTER, CONTROL

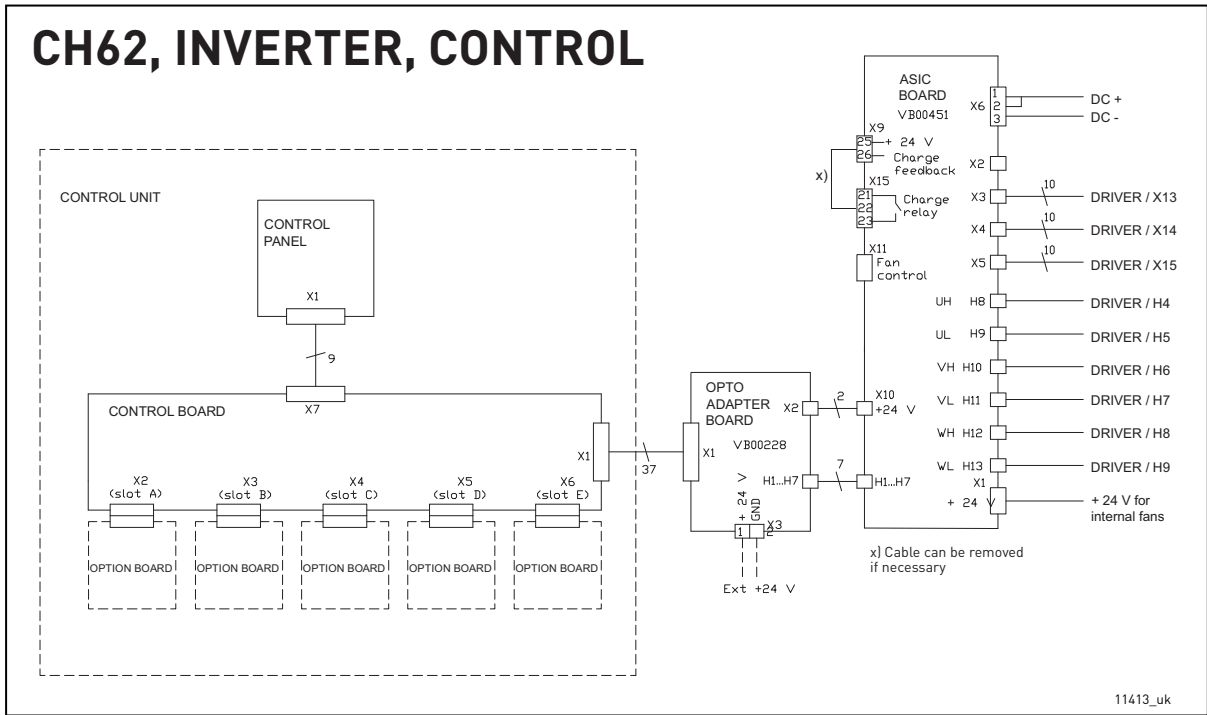

CH63, FC, MODULE 1

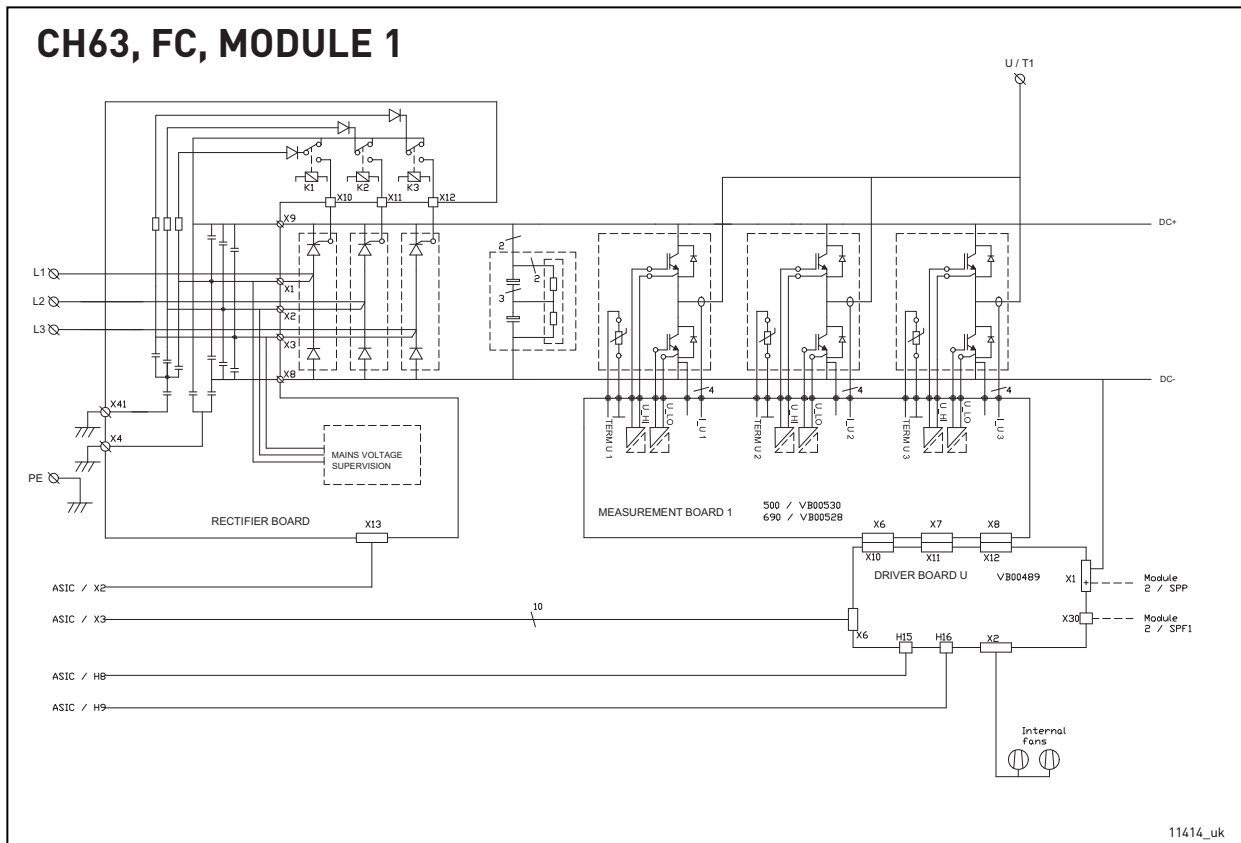

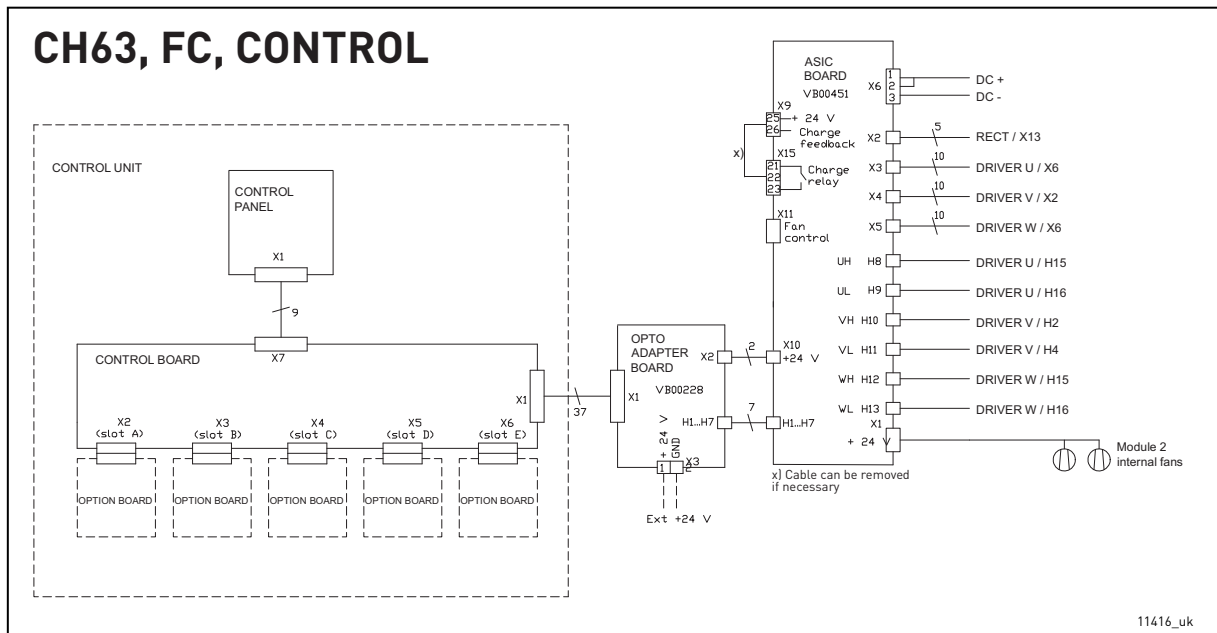
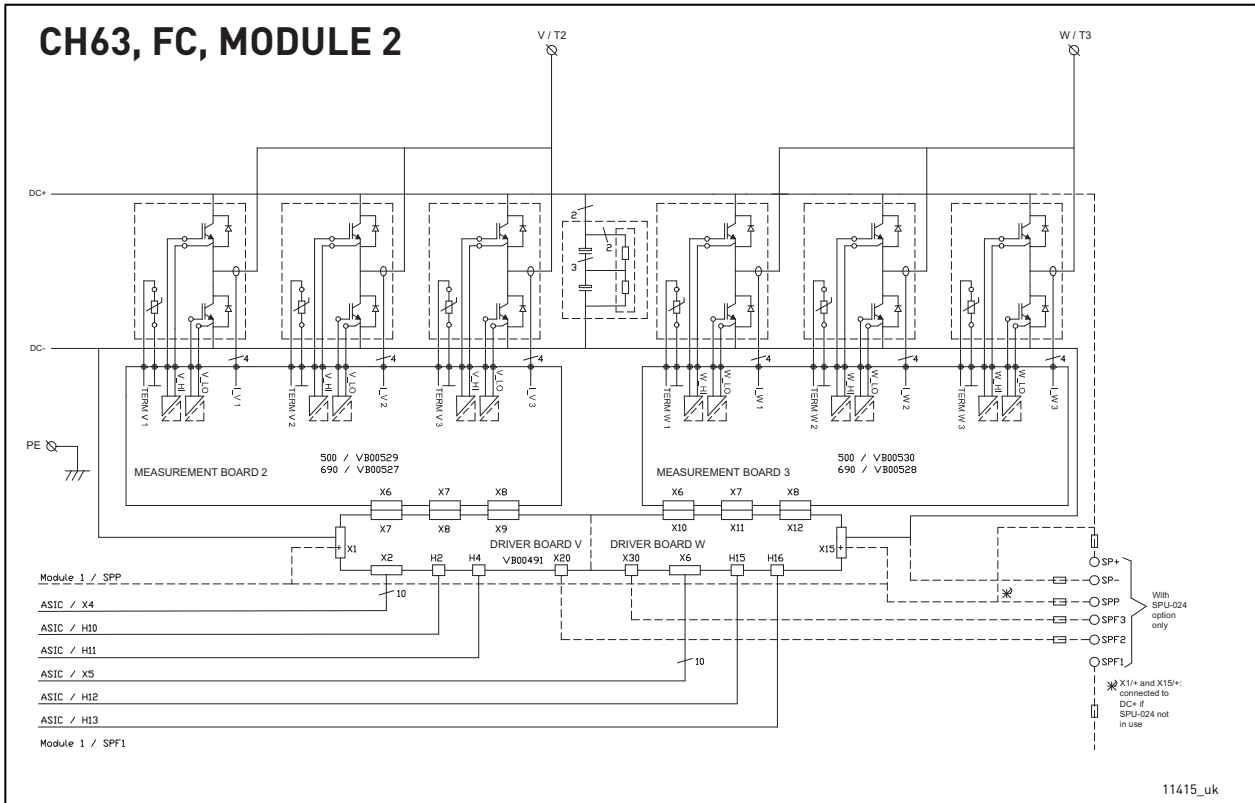

CH63, INVERTER, MODULE 1

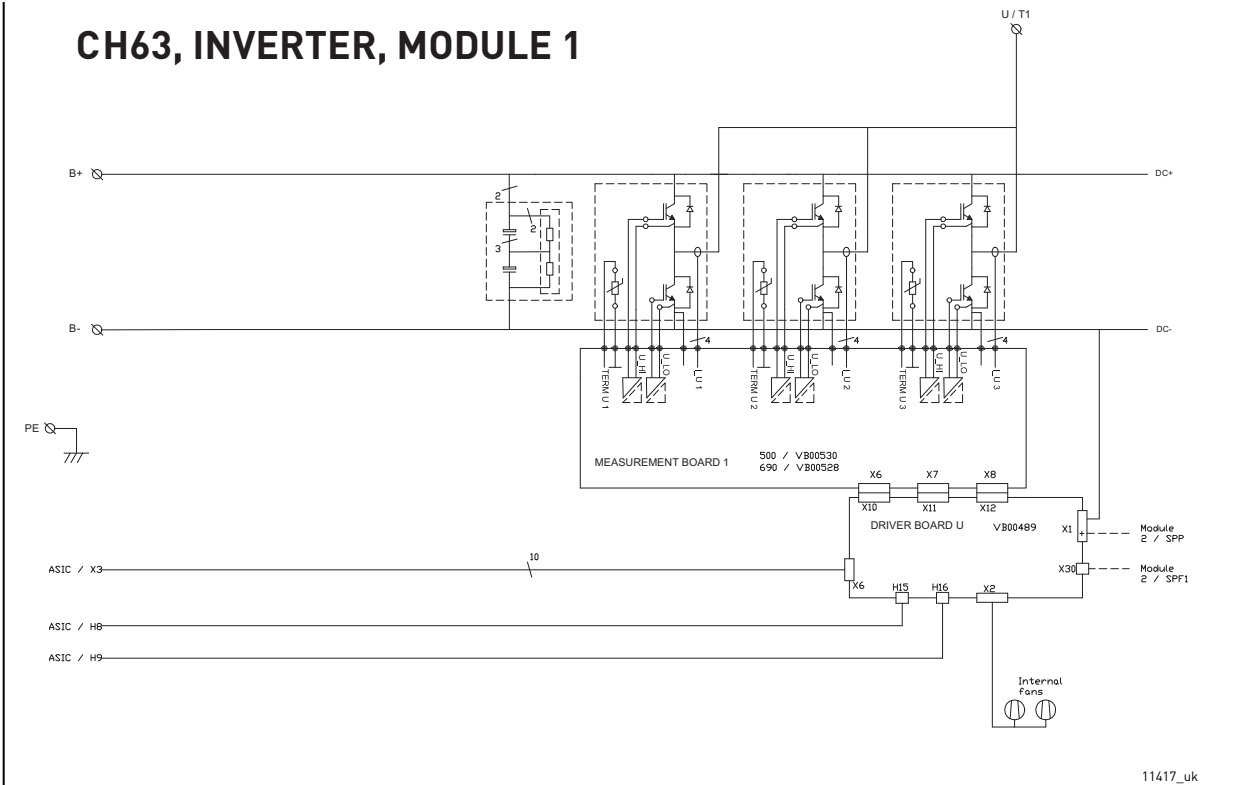

CH63, INVERTER, MODULE 2

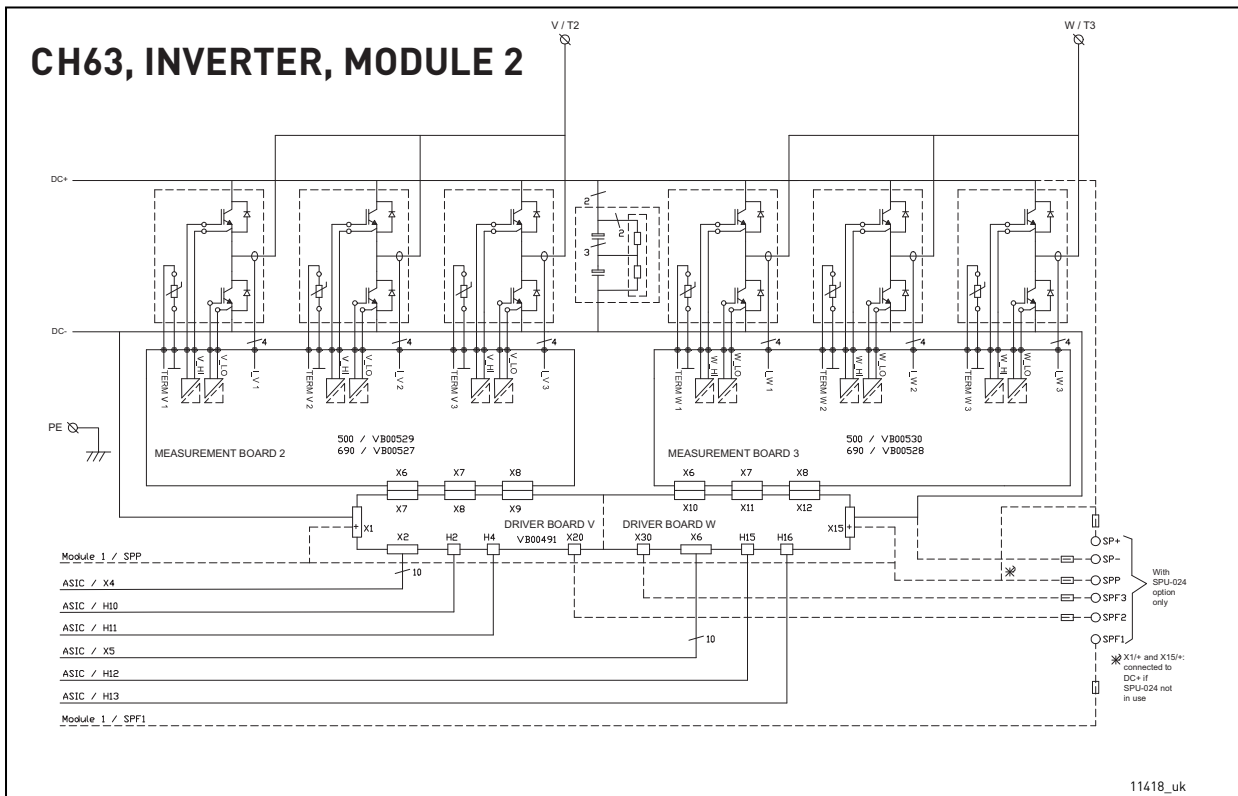

CH63, INVERTER, CONTROL

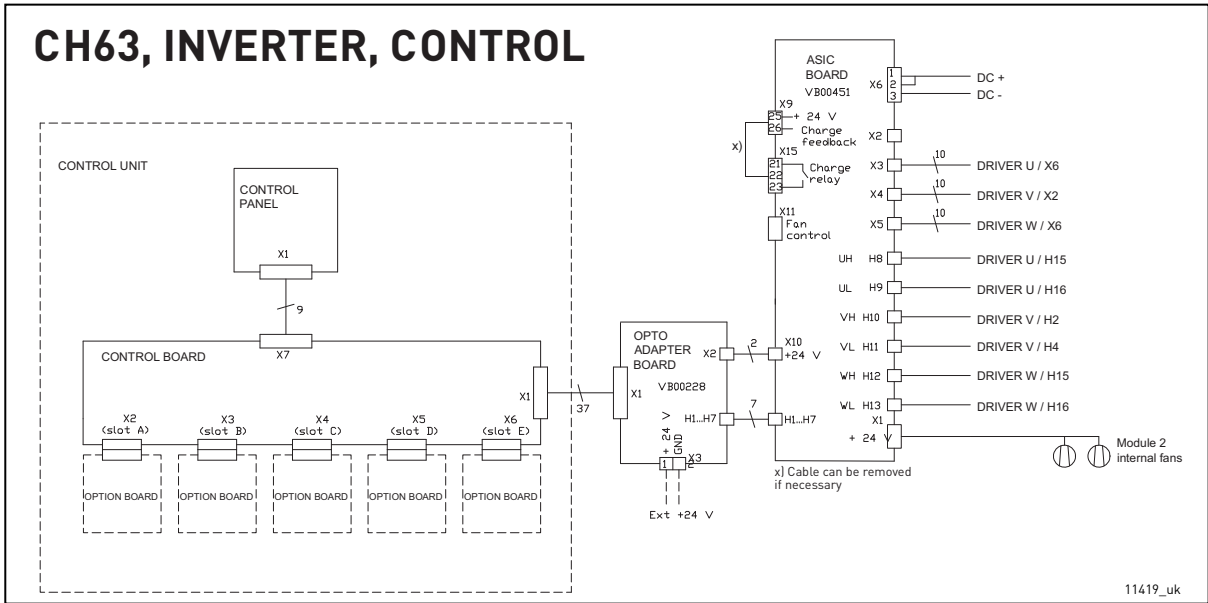

CH64, INVERTER, PHASE U

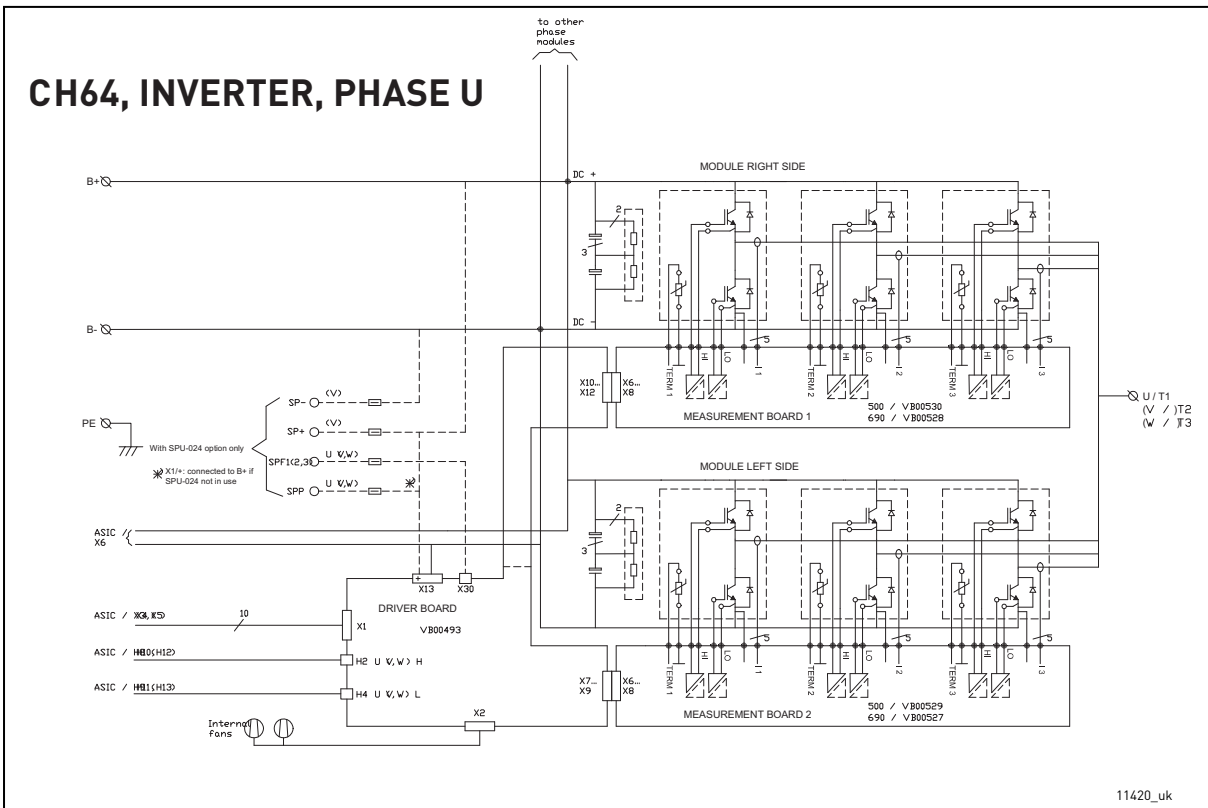

CH64, INVERTER, CONTROL

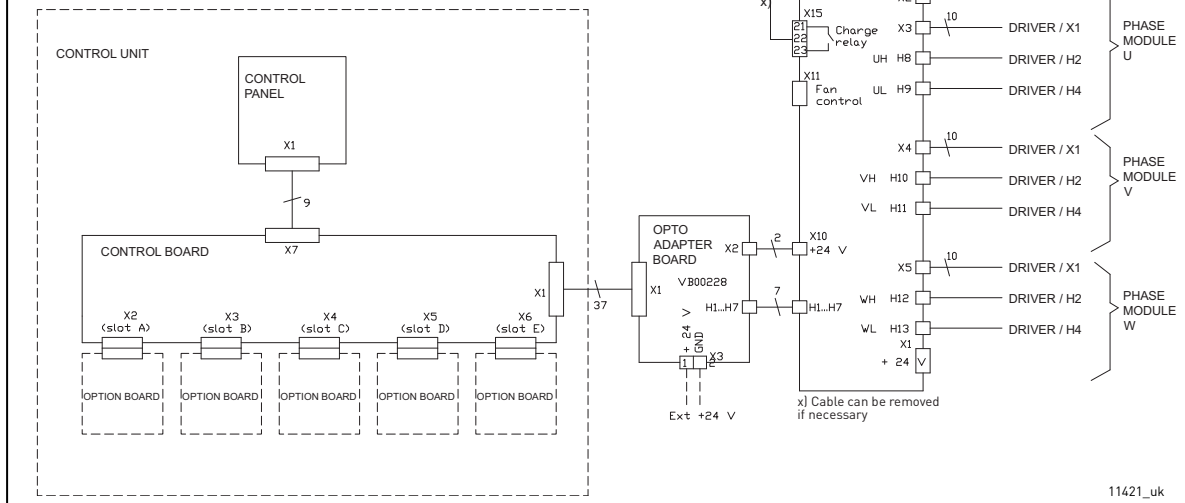

CH72, FC

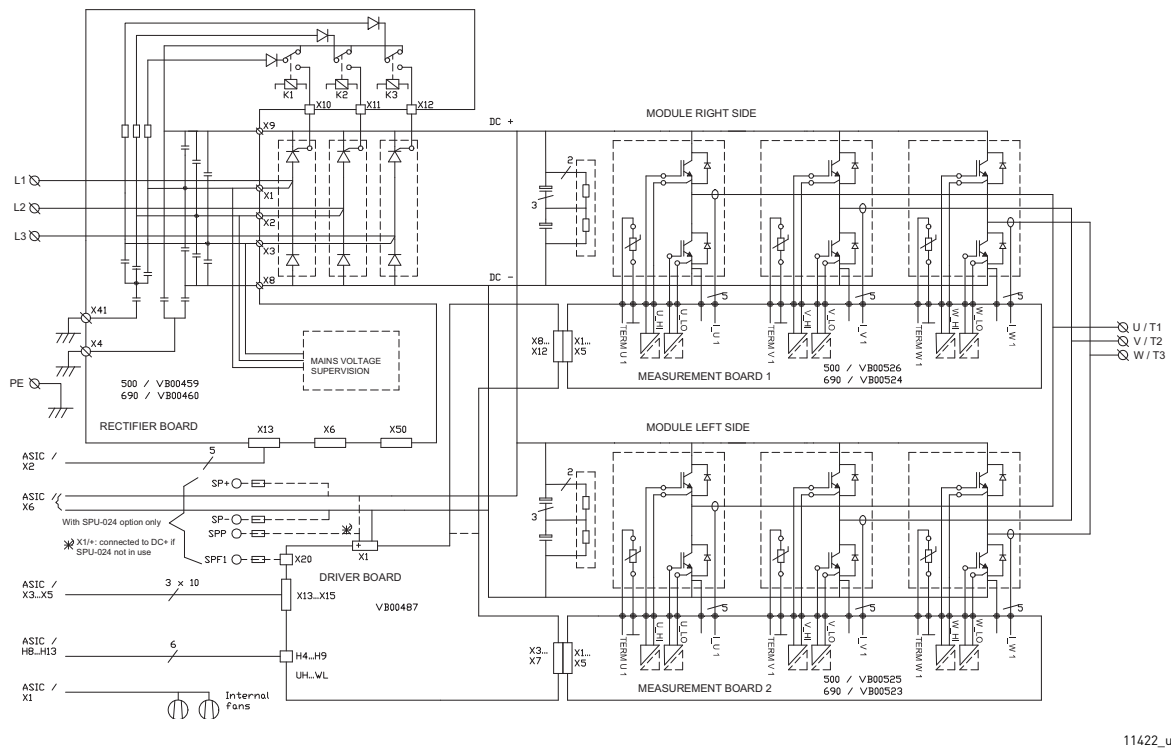

CH72, FC, CONTROL

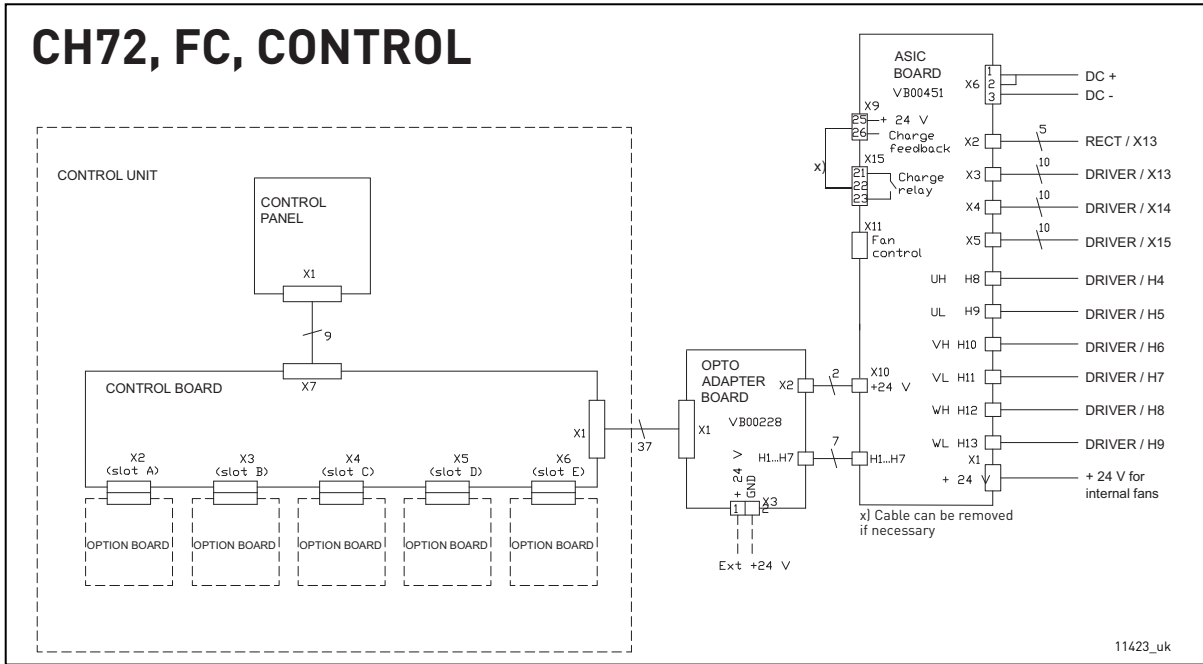

CH74, FC, PHASE U

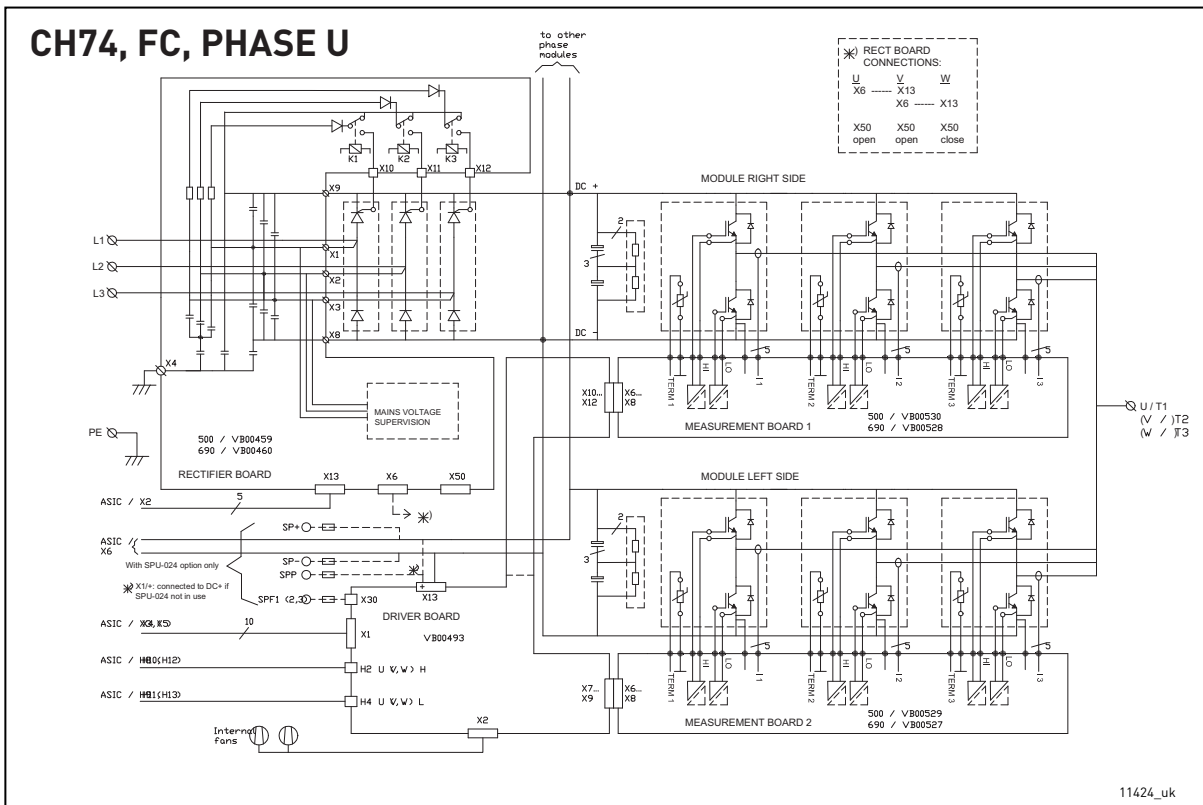

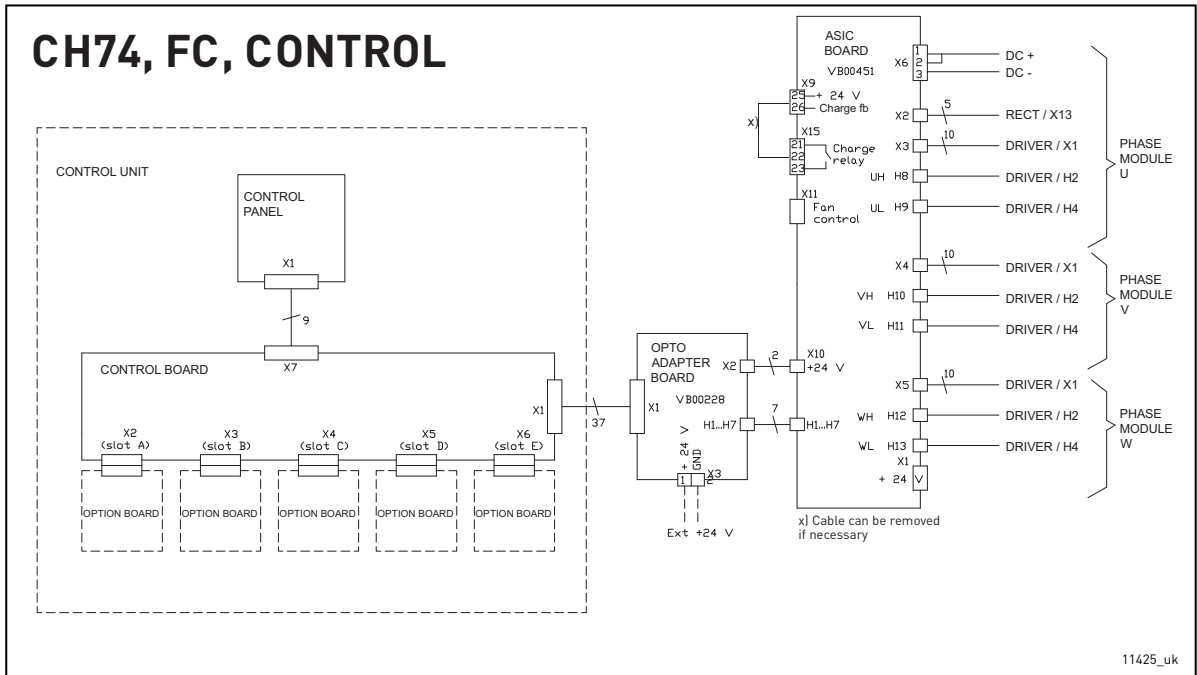

Appendix 2

OETL2500 + OFAX3 + Charging circuit for VACON® NX Liquid-Cooled inverters 1640_5 to 2300_5 (3 diagrams)

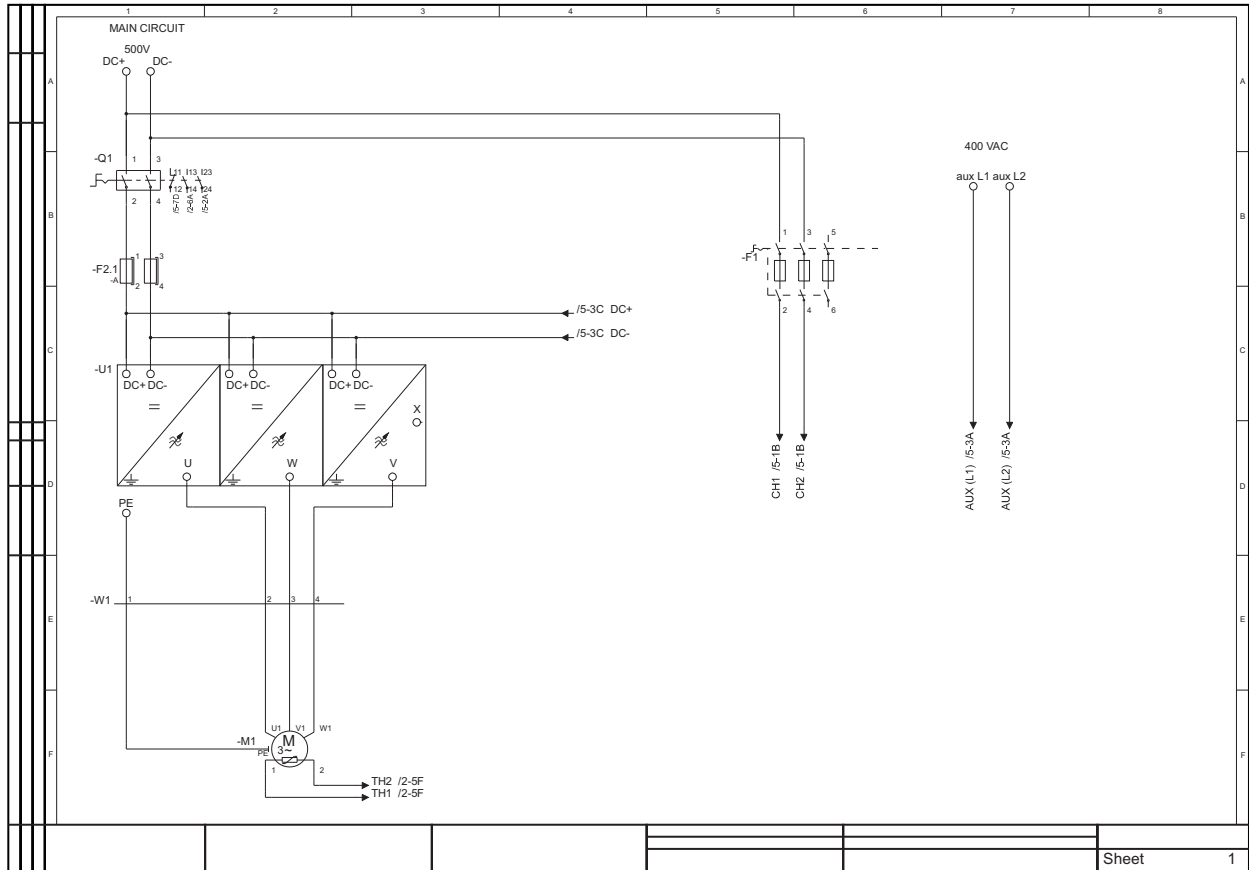

Sheet 1

11426_00

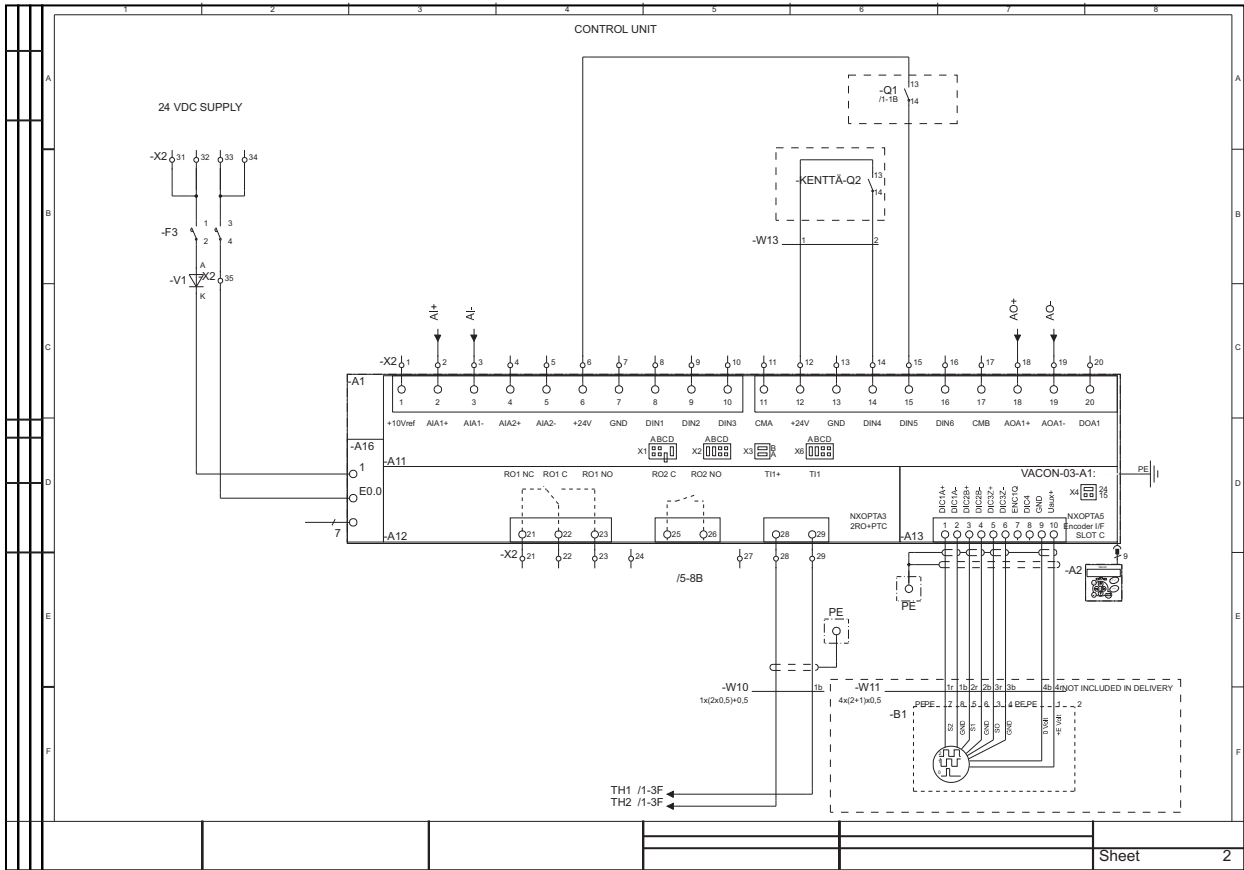

Sheet 2

11427 00

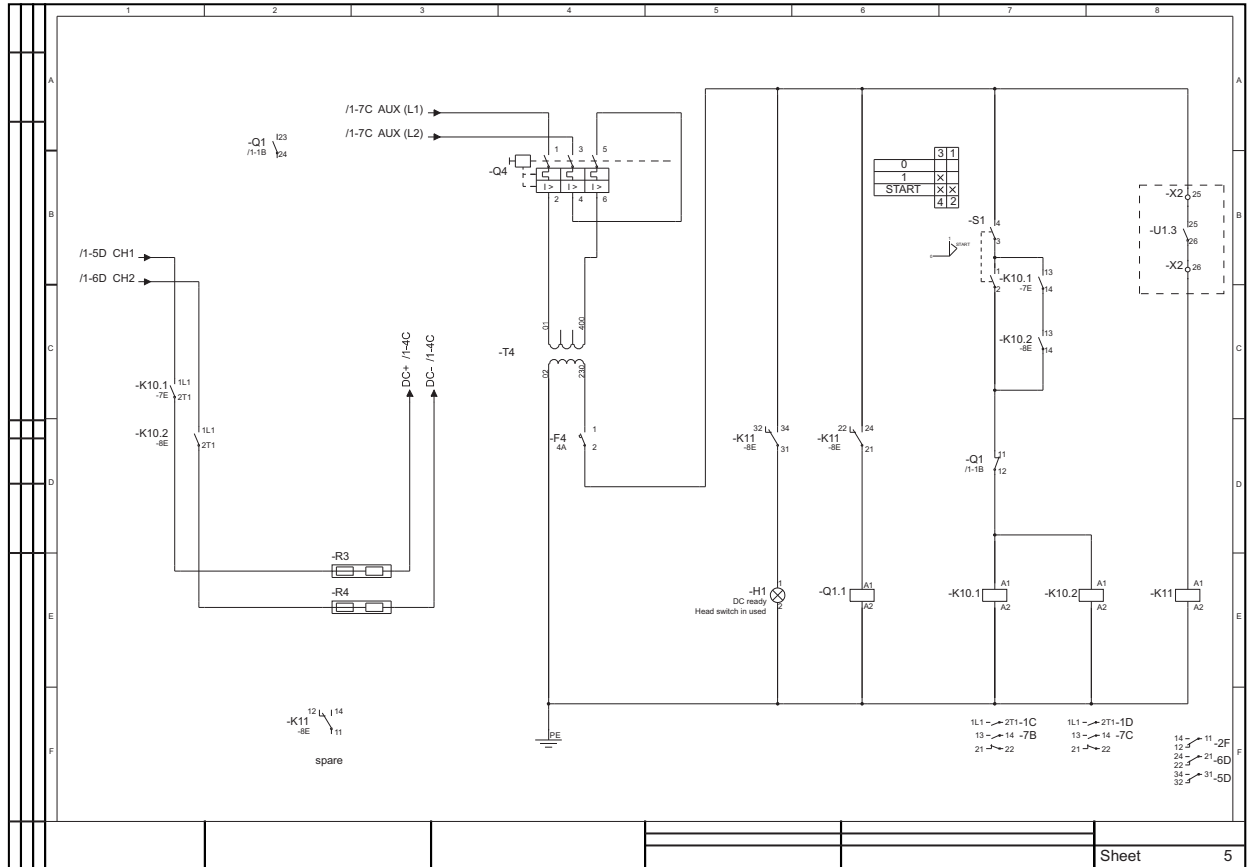

Appendix 3

Fuse sizes, Bussman aR fuses

Fuse information

Max fuse ambient temperature +50 °C.

Fuse sizes can differ in the same chassis. Make sure that the I_{sc} of the supply transformer is high enough to burn fuses fast enough.

Check the current rating of the fuse bases according to the input current of the drive.

The physical size of the fuse is chosen on the basis of the fuse current: Current < 400 amps (size 2 fuse or smaller), current < 400 amps (size 3 fuse).

Table 112. Fuse sizes (Bussman aR) for VACON® NX Liquid-Cooled (500 V) AC drives

Chassis	Type	I _{th} [A]	DIN43620		DIN43653 (80mm)		DIN43653 (110mm)		Fuse Un [V]	Fuse In [A]	Qty. of fuses per phase 3~/6~
			aR fuse part nr.	Fuse size	aR fuse part nr.	Fuse size	aR fuse part nr.	Fuse size			
CH3	0016	16	170M1565	DIN000	170M1415	000T/80			690	63	1
CH3	0022	22	170M1565	DIN000	170M1415	000T/80			690	63	1
CH3	0031	31	170M1565	DIN000	170M1415	000T/80			690	63	1
CH3	0038	38	170M1565	DIN000	170M1415	000T/80			690	63	1
CH3	0045	45	170M1567	DIN000	170M1417	000T/80			690	100	1
CH3	0061	61	170M1567	DIN000	170M1417	000T/80			690	100	1
CH4	0072	72	170M3815	DIN1 ¹	170M3065	1*TN/80	170M3215	1*TN/110	690	200	1
CH4	0087	87	170M3815	DIN1 ¹	170M3065	1*TN/80	170M3215	1*TN/110	690	200	1
CH4	0105	105	170M3815	DIN1 ¹	170M3065	1*TN/80	170M3215	1*TN/110	690	200	1
CH4	0140	140	170M3815	DIN1 ¹	170M3065	1*TN/80	170M3215	1*TN/110	690	200	1
CH5	0168	168	170M3819	DIN1 ¹	170M3069	1*TN/80	170M3219	1*TN/110	690	400	1
CH5	0205	205	170M3819	DIN1 ¹	170M3069	1*TN/80	170M3219	1*TN/110	690	400	1
CH5	0261	261	170M3819	DIN1 ¹	170M3069	1*TN/80	170M3219	1*TN/110	690	400	1
CH61	0300	300	170M5813	DIN2	170M5063	2TN/80	170M5213	2TN/110	690	700	1
CH61	0385	385	170M5813	DIN2	170M5063	2TN/80	170M5213	2TN/110	690	700	1
CH72	0460	460	170M6814	DIN3	170M6064	3TN/80	170M6214	3TN/110	690	1000	1
CH72 ²	0460	460	170M6813	DIN2	170M5063	2TN/80	170M5213	2TN/110	690	700	1
CH72	0520	520	170M6814	DIN3	170M6064	3TN/80	170M6214	3TN/110	690	1000	1
CH72 ²	0520	520	170M6813	DIN2	170M5063	2TN/80	170M5213	2TN/110	690	700	1
CH72	0590	590	170M6814	DIN3	170M6064	3TN/80	170M6214	3TN/110	690	1000	1
CH72 ²	0590	590	170M6813	DIN2	170M5063	2TN/80	170M5213	32N/110	690	700	1
CH72	0650	650	170M8547	3SHT ³	170M6066	3TN/80	170M6216	3TN/110	690	1250	1
CH72 ²	0650	650	170M5813	DIN2	170M5063	2TN/80	170M5213	2TN/110	690	700	1
CH72	0730	730	170M8547	3SHT ³	170M6066	3TN/80	170M6216	3TN/110	690	1250	1
CH72 ²	0730	730	170M5813	DIN2	170M5063	2TN/80	170M5213	2TN/110	690	700	1
CH63	0820	820	170M6812	DIN3	170M6062	3TN/80	170M6212	3TN/110	690	800	2
CH63	0920	920	170M6812	DIN3	170M6062	3TN/80	170M6212	3TN/110	690	800	2

Table 112. Fuse sizes (Bussman aR) for VACON® NX Liquid-Cooled (500 V) AC drives

Chassis	Type	I _{th} [A]	DIN43620		DIN43653 (80mm)		DIN43653 (110mm)		Fuse U _n [V]	Fuse I _n [A]	Qty. of fuses per phase 3~/6~
			aR fuse part nr.	Fuse size	aR fuse part nr.	Fuse size	aR fuse part nr.	Fuse size			
CH63	1030	1030	170M6814	DIN3	170M6064	3TN/80	170M6214	3TN/110	690	1000	2
CH63	1150	1150	170M6814	DIN3	170M6064	3TN/80	170M6214	3TN/110	690	1000	2
CH74	1370	1370	170M6814	DIN3	170M6064	3TN/80	170M6214	3TN/110	690	1000	3
<i>CH74²</i>	<i>1370</i>	<i>1370</i>	<i>170M6812</i>	<i>DIN3</i>	<i>170M6062</i>	<i>3TN/80</i>	<i>170M6212</i>	<i>3TN/110</i>	<i>690</i>	<i>800</i>	<i>2</i>
CH74	1640	1640	170M6814	DIN3	170M6064	3TN/80	170M6214	3TN/110	690	1000	3
<i>CH74²</i>	<i>1640</i>	<i>1640</i>	<i>170M6812</i>	<i>DIN3</i>	<i>170M6062</i>	<i>3TN/80</i>	<i>170M6212</i>	<i>3TN/110</i>	<i>690</i>	<i>800</i>	<i>2</i>
CH74	2060	2060	170M8547	3SHT ³	170M6066	3TN/80	170M6216	3TN/110	690	1250	3
<i>CH74²</i>	<i>2060</i>	<i>2060</i>	<i>170M6814</i>	<i>DIN3</i>	<i>170M6064</i>	<i>3TN/80</i>	<i>170M6214</i>	<i>3TN/110</i>	<i>690</i>	<i>1000</i>	<i>2</i>
CH74	2300	2300	170M8547	3SHT ³	170M6066	3TN/80	170M6216	3TN/110	690	1250	3
<i>CH74²</i>	<i>2300</i>	<i>2300</i>	<i>170M6814</i>	<i>DIN3</i>	<i>170M6064</i>	<i>3TN/80</i>	<i>170M6214</i>	<i>3TN/110</i>	<i>690</i>	<i>1000</i>	<i>2</i>

¹ T_j = 25 °C

² Data in Italic refer to drives with 12-pulse supply

³ SHT fuses can be assembled into DIN fuse base of the corresponding size

Table 113. Fuse sizes (Bussman aR) for VACON® NX Liquid-Cooled (690 V) AC drives

Chassis	Type	I _{th} [A]	DIN43620		DIN43653 (80mm)		DIN43653 (110mm)		Fuse U _n [V]	Fuse I _n [A]	Qty. of fuses per phase 3~/6~
			aR fuse part nr.	Fuse size	aR fuse part nr.	Fuse size	aR fuse part nr.	Fuse size			
CH61	0170	170	170M3819	DIN1 ¹	170M3069	1*TN/80	170M3219	1*TN/110	690	400	1
CH61	0208	208	170M3819	DIN1 ¹	170M3069	1*TN/80	170M3219	1*TN/110	690	400	1
CH61	0261	261	170M3819	DIN1 ¹	170M3069	1*TN/80	170M3219	1*TN/110	690	400	1
CH72	0325	325	170M5813	DIN2	170M5063	2TN/80	170M5213	2TN/110	690	700	1
<i>CH72²</i>	<i>0325</i>	<i>325</i>	<i>170M3819</i>	<i>DIN1¹</i>	<i>170M3069</i>	<i>1*TN/80</i>	<i>170M3219</i>	<i>1*TN/110</i>	<i>690</i>	<i>400</i>	<i>1</i>
CH72	0385	385	170M5813	DIN2	170M5063	2TN/80	170M5213	2TN/110	690	700	1
<i>CH72²</i>	<i>0385</i>	<i>385</i>	<i>170M3819</i>	<i>DIN1¹</i>	<i>170M3069</i>	<i>1*TN/80</i>	<i>170M3219</i>	<i>1*TN/110</i>	<i>690</i>	<i>400</i>	<i>1</i>
CH72	0416	416	170M6812	DIN3	170M6062	3TN/80	170M6212	3TN/110	690	800	1
<i>CH72²</i>	<i>0416</i>	<i>416</i>	<i>170M3819</i>	<i>DIN1¹</i>	<i>170M3069</i>	<i>1*TN/80</i>	<i>170M3219</i>	<i>1*TN/110</i>	<i>690</i>	<i>400</i>	<i>1</i>
CH72	0460	460	170M6812	DIN3	170M6062	3TN/80	170M6212	3TN/110	690	800	1
<i>CH72²</i>	<i>0460</i>	<i>460</i>	<i>170M3819</i>	<i>DIN1¹</i>	<i>170M3069</i>	<i>1*TN/80</i>	<i>170M3219</i>	<i>1*TN/110</i>	<i>690</i>	<i>400</i>	<i>1</i>
CH72	0502	502	170M6812	DIN3	170M6062	3TN/80	170M6212	3TN/110	690	800	1
<i>CH72²</i>	<i>0502</i>	<i>502</i>	<i>170M3819</i>	<i>DIN1¹</i>	<i>170M3069</i>	<i>1*TN/80</i>	<i>170M3219</i>	<i>1*TN/110</i>	<i>690</i>	<i>400</i>	<i>1</i>
CH63	0590	590	170M6814	DIN3	170M6064	3TN/80	170M6214	3TN/110	690	1100	1

Table 113. Fuse sizes (Bussman aR) for VACON® NX Liquid-Cooled (690 V) AC drives

Chassis	Type	I _{th} [A]	DIN43620		DIN43653 (80mm)		DIN43653 (110mm)		Fuse U _n [V]	Fuse I _n [A]	Qty. of fuses per phase 3~/6~
			aR fuse part nr.	Fuse size	aR fuse part nr.	Fuse size	aR fuse part nr.	Fuse size			
CH63	0650	650	170M8547	3SHT ³	170M6066	3TN/80	170M6216	3TN/110	690	1250	1
CH63	0750	750	170M8547	3SHT ³	170M6066	3TN/80	170M6216	3TN/110	690	1250	1
CH74	0820	820	170M5813	DIN2	170M5063	2TN/80	170M5213	2TN/110	690	700	3
<i>CH74²</i>	<i>0820</i>	<i>820</i>	<i>170M6812</i>	<i>DIN3</i>	<i>170M6062</i>	<i>3TN/80</i>	<i>170M6212</i>	<i>3TN/110</i>	<i>690</i>	<i>800</i>	<i>1</i>
CH74	0920	920	170M5813	DIN2	170M5063	2TN/80	170M5213	2TN/110	690	700	3
<i>CH74²</i>	<i>0920</i>	<i>920</i>	<i>170M6812</i>	<i>DIN3</i>	<i>170M6062</i>	<i>3TN/80</i>	<i>170M6212</i>	<i>3TN/110</i>	<i>690</i>	<i>800</i>	<i>1</i>
CH74	1030	1030	170M5813	DIN2	170M5063	2TN/80	170M5213	2TN/110	690	700	3
<i>CH74²</i>	<i>1030</i>	<i>1030</i>	<i>170M6814</i>	<i>DIN3</i>	<i>170M6064</i>	<i>3TN/80</i>	<i>170M6214</i>	<i>3TN/110</i>	<i>690</i>	<i>1000</i>	<i>1</i>
CH74	1180	1180	170M5813	DIN2	170M5063	2TN/80	170M5213	2TN/110	690	700	3
<i>CH74²</i>	<i>1180</i>	<i>1180</i>	<i>170M6814</i>	<i>DIN3</i>	<i>170M6064</i>	<i>3TN/80</i>	<i>170M6214</i>	<i>3TN/110</i>	<i>690</i>	<i>1000</i>	<i>1</i>
CH74	1300	1300	170M6814	DIN3	170M6064	3TN/80	170M6214	3TN/110	690	1000	3
<i>CH74²</i>	<i>1300</i>	<i>1300</i>	<i>170M8547</i>	<i>3SHT³</i>	<i>170M6066</i>	<i>3TN/80</i>	<i>170M6216</i>	<i>3TN/110</i>	<i>690</i>	<i>1250</i>	<i>1</i>
CH74	1500	1500	170M6814	DIN3	170M6064	3TN/80	170M6214	3TN/110	690	1000	3
<i>CH74²</i>	<i>1500</i>	<i>1500</i>	<i>170M8547</i>	<i>3SHT³</i>	<i>170M6066</i>	<i>3TN/80</i>	<i>170M6216</i>	<i>3TN/110</i>	<i>690</i>	<i>1250</i>	<i>1</i>
CH74	1700	1700	170M6814	DIN3	170M6064	3TN/80	170M6214	3TN/110	690	1000	3
<i>CH74²</i>	<i>1700</i>	<i>1700</i>	<i>170M6812</i>	<i>DIN3</i>	<i>170M6064</i>	<i>3TN/80</i>	<i>170M6212</i>	<i>3TN/110</i>	<i>690</i>	<i>800</i>	<i>1</i>

¹ T_j = 25 °C

² Data in Italic refer to drives with 12-pulse supply

³ SHT fuses can be assembled into DIN fuse base of the corresponding size

Table 114. Fuse sizes (Bussman aR) for VACON® NX Liquid-Cooled (450–800 V) inverters

Chassis	Type	I _{th} [A]	DIN43620		DIN43653 (80mm)		DIN43653 (110mm)		Fuse U _n [V]	Fuse I _n [A]	Qty. of fuses/pole
			aR fuse part nr.	Fuse size	aR fuse part nr	Fuse size	aR fuse part nr.	Fuse size			
CH3	0016	16	170M3810	DIN1 ¹	170M3060	1*TN/80	170M3210	1*TN/110	690	63	1
CH3	0022	22	170M3810	DIN1 ¹	170M3060	1*TN/80	170M3210	1*TN/110	690	63	1
CH3	0031	31	170M3810	DIN1 ¹	170M3060	1*TN/80	170M3210	1*TN/110	690	63	1
CH3	0038	38	170M3813	DIN1 ¹	170M3063	1*TN/80	170M3213	1*TN/110	690	125	1
CH3	0045	45	170M3813	DIN1 ¹	170M3063	1*TN/80	170M3213	1*TN/110	690	125	1
CH3	0061	61	170M3813	DIN1 ¹	170M3063	1*TN/80	170M3213	1*TN/110	690	125	1
CH4	0072	72	170M3815	DIN1 ¹	170M3063	1*TN/80	170M3213	1*TN/110	690	200	1
CH4	0087	87	170M3815	DIN1 ¹	170M3065	1*TN/80	170M3215	1*TN/110	690	200	1
CH4	0105	105	170M3815	DIN1 ¹	170M3065	1*TN/80	170M3215	1*TN/110	690	200	1
CH4	0140	140	170M3819	DIN1 ¹	170M3069	1*TN/80	170M3219	1*TN/110	690	400	1
CH5	0168	168	170M3819	DIN1 ¹	170M3069	1*TN/80	170M3219	1*TN/110	690	400	1
CH5	0205	205	170M3819	DIN1 ¹	170M3069	1*TN/80	170M3219	1*TN/110	690	400	1
CH5	0261	261	170M6808	DIN3	170M6058	3TN/80	170M6208	3TN/110	690	500	1
CH61	0300	300	170M6812	DIN3	170M6062	3TN/80	170M6212	3TN/110	690	800	1
CH61	0385	385	170M6812	DIN3	170M6062	3TN/80	170M6212	3TN/110	690	800	1
CH62	0460	460	170M6814	DIN3	170M6064	3TN/80	170M6214	3TN/110	690	1000	1
CH62	0520	520	170M6814	DIN3	170M6064	3TN/80	170M6214	3TN/110	690	1000	1
CH62	0590	590	170M6812	DIN3	170M6062	3TN/80	170M6212	3TN/110	690	800	2
CH62	0650	650	170M6812	DIN3	170M6062	3TN/80	170M6212	3TN/110	690	800	2
CH62	0730	730	170M6812	DIN3	170M6062	3TN/80	170M6212	3TN/110	690	800	2
CH63	0820	820	170M6814	DIN3	170M6064	3TN/80	170M6214	3TN/110	690	1000	2
CH63	0920	920	170M6814	DIN3	170M6064	3TN/80	170M6214	3TN/110	690	1000	2
CH63	1030	1030	170M6812	DIN3	170M6062	3TN/80	170M6212	3TN/110	690	800	3
CH63	1150	1150	170M6812	DIN3	170M6062	3TN/80	170M6212	3TN/110	690	800	3
CH64	1370	1370	170M8547	3SHT ²	170M6066	3TN/80	170M6216	3TN/110	690	1250	3
CH64	1640	1640	170M8547	3SHT ²	170M6066	3TN/80	170M6216	3TN/110	690	1250	3
CH64	2060	2060	170M8550	3SHT ²	170M6069	3TN/80	170M6219	3TN/110	690	1600	3
CH64	2300	2300	170M8550	3SHT ²	170M6069	3TN/80	170M6219	3TN/110	690	1600	3

¹ T_j = 25 °C

² SHT fuses can be assembled into DIN fuse base of the corresponding size

Fuse sizes (Bussman aR) for VACON® NX Liquid-Cooled (640–1100 V) inverters

Chassis	Type	I _{th} [A]	DIN43620		DIN43653 (110mm)		Fuse U _n [V]	Fuse I _n [A]	Qty. of fuses/pole
			aR fuse part nr.	Fuse size ¹	aR fuse part nr.	Fuse size			
CH61	0170	170	170M4199	1SHT	170M4985	1TN/110	1250	400	1
CH61	0208	208	170M4199	1SHT	170M4985	1TN/110	1250	400	1
CH61	0261	261	170M6202	3SHT	170M8633	3TN/110	1250	500	1
CH62	0325	325	170M6305	3SHT	170M8636	3TN/110	1250	700	1
CH62	0385	385	170M6305	3SHT	170M8636	3TN/110	1250	700	1
CH62	0416	416	170M6277	3SHT	170M8639	3TN/110	1100	1000	1
CH62	0460	460	170M6277	3SHT	170M8639	3TN/110	1100	1000	1
CH62	0502	502	170M6277	3SHT	170M8639	3TN/110	1100	1000	1
CH63	0590	590	170M6305	3SHT	170M8636	3TN/110	1250	700	2
CH63	0650	650	170M6305	3SHT	170M8636	3TN/110	1250	700	2
CH63	0750	750	170M6305	3SHT	170M8636	3TN/110	1250	700	2
CH64	0820	820	170M6277	3SHT	170M8639	3TN/110	1100	1000	2
CH64	0920	920	170M6277	3SHT	170M8639	3TN/110	1100	1000	2
CH64	1030	1030	170M6277	3SHT	170M8639	3TN/110	1100	1000	3
CH64	1180	1180	170M6277	3SHT	170M8639	3TN/110	1100	1000	3
CH64	1300	1300	170M6277	3SHT	170M8639	3TN/110	1100	1000	3
CH64	1500	1500	170M6277	3SHT	170M8639	3TN/110	1100	1000	3
CH64	1700	1700	170M6277	3SHT	170M8639	3TN/110	1100	1000	3

¹ SHT fuses can be assembled into DIN fuse base of the corresponding size

Table 115. Fuse sizes (Bussman aR) for VACON® NX AFE units (380–500 V)

Chassis	Type	I _{th} [A]	DIN43620		DIN43653 (80mm)		DIN43653 (110mm)		Fuse U _n [V]	Fuse I _n [A]	Qty. of fuses / phase 3~
			aR fuse part nr.	Fuse size ¹	aR fuse part nr.	Fuse size ¹	aR fuse part nr.	Fuse size ¹			
CH3	0016	16	170M2679	DIN00	170M4828	00TN/80			1000	63	1
CH3	0022	22	170M2679	DIN00	170M4828	00TN/80			1000	63	1
CH3	0031	31	170M2679	DIN00	170M4828	00TN/80			1000	63	1
CH3	0038	38	170M2679	DIN00	170M4828	00TN/80			1000	63	1
CH3	0045	45	170M2683	DIN00	170M4832	00TN/80			1000	160	1
CH3	0061	61	170M2683	DIN00	170M4832	00TN/80			1000	160	1
CH4	0072	72	170M2683	DIN00	170M4832	00TN/80			1000	160	1
CH4	0087	87	170M2683	DIN00	170M4832	00TN/80			1000	16	1
CH4	0105	105	170M2683	DIN00	170M4832	00TN/80			1000	160	1
CH4	0140	140	170M4199	1SHT			170M4985	1TN/110	1250	400	1
CH5	0168	168	170M4199	1SHT			170M4985	1TN/110	1250	400	1
CH5	0205	205	170M4199	1SHT			170M4985	1TN/110	1250	400	1
CH5	0261	261	170M4199	1SHT			170M4985	1TN/110	1250	400	1
CH61	0300	300	170M6202	3SHT			170M8633	3TN/110	1250	500	1
CH61	0385	385	170M6305	3SHT			170M8636	3TN/110	1250	700	1

Table 115. Fuse sizes (Bussman aR) for VACON® NX AFE units (380–500 V)

Chassis	Type	I _{th} [A]	DIN43620		DIN43653 (80mm)		DIN43653 (110mm)		Fuse U _n [V]	Fuse I _n [A]	Qty. of fuses / phase 3~
			aR fuse part nr.	Fuse size ¹	aR fuse part nr.	Fuse size ¹	aR fuse part nr.	Fuse size ¹			
CH62	0460	460	170M6277	3SHT			170M8639	3TN/110	1100	1000	1
CH62	0520	520	170M6277	3SHT			170M8639	3TN/110	1100	1000	1
CH62	0590	590	170M6277	3SHT			170M8639	3TN/110	1100	1000	1
CH62	0650	650	170M6305	3SHT			170M8636	3TN/110	1250	700	2
CH62	0730	730	170M6305	3SHT			170M8636	3TN/110	1250	700	2
CH63	0820	820	170M6305	3SHT			170M8636	3TN/110	1250	700	2
CH63	0920	920	170M6277	3SHT			170M8639	3TN/110	1100	1000	2
CH63	1030	1030	170M6277	3SHT			170M8639	3TN/110	1100	1000	2
CH63	1150	1150	170M6277	3SHT			170M8639	3TN/110	1100	1000	2
CH64	1370	1370	170M6277	3SHT			170M8639	3TN/110	1100	1000	3
CH64	1640	1640	170M6277	3SHT			170M8639	3TN/110	1100	1000	3
CH64	2060	2060	170M6277	3SHT			170M8639	3TN/110	1100	1000	4
CH64	2300	2300	170M6277	3SHT			170M8639	3TN/110	1100	1000	4

¹ SHT fuses can be assembled into DIN fuse base of the corresponding size

Table 116. Fuse sizes (Bussman aR) for VACON® NX AFE units (525—690 V)

Chassis	Type	I _{th} [A]	DIN43620		DIN43653 (110mm)		Fuse U _n [V]	Fuse I _n [A]	Qty. of fuses / phase 3~
			aR fuse part nr.	Fuse size ¹	aR fuse part nr.	Fuse size ¹			
CH61	0170	170	170M4199	1SHT	170M4985	1TN/110	1250	400	1
CH61	0208	208	170M4199	1SHT	170M4985	1TN/110	1250	400	1
CH61	0261	261	170M4199	1SHT	170M4985	1TN/110	1250	400	1
CH62	0325	325	170M6305	3SHT	170M8636	3TN/110	1250	700	1
CH62	0385	385	170M6305	3SHT	170M8636	3TN/110	1250	700	1
CH62	0416	416	170M6305	3SHT	170M8636	3TN/110	1250	700	1
CH62	0460	460	170M6277	3SHT	170M8639	3TN/110	1100	1000	1
CH62	0502	502	170M6277	3SHT	170M8639	3TN/110	1100	1000	1
CH63	0590	590	170M6277	3SHT	170M8639	3TN/110	1100	1000	1
CH63	0650	650	170M6305	3SHT	170M8636	3TN/110	1250	700	2
CH63	0750	750	170M6305	3SHT	170M8636	3TN/110	1250	700	2
CH64	0820	820	170M6305	3SHT	170M8636	3TN/110	1250	700	2
CH64	0920	920	170M6277	3SHT	170M8639	3TN/110	1100	1000	2
CH64	1030	1030	170M6277	3SHT	170M8639	3TN/110	1100	1000	2
CH64	1180	1180	170M6277	3SHT	170M8639	3TN/110	1100	1000	2
CH64	1300	1300	170M6305	3SHT	170M8636	3TN/110	1250	700	3
CH64	1500	1500	170M6277	3SHT	170M8639	3TN/110	1100	1000	3

¹ SHT fuses can be assembled into DIN fuse base of the corresponding size

Table 117. Brake chopper unit fuse selection (Bussman aR), mains voltage 465–800 Vdc

Chassis	Type	Min resistor value, 2* [ohm]	Braking current	DIN43620		Fuse U _n [V]	Fuse I _n [A]	Qty. of fuses per pole
				aR fuse part nr.	Fuse size ¹			
CH3	0016	52.55	32	170M2679	DIN00	690	63	1
CH3	0022	38.22	44	170M2679	DIN00	690	63	1
CH3	0031	27.12	62	170M2679	DIN00	690	63	1
CH3	0038	22.13	76	170M2679	DIN00	690	63	1
CH3	0045	18.68	90	170M2683	DIN00	690	160	1
CH3	0061	13.78	122	170M2683	DIN00	690	160	1
CH4	0072	11.68	144	170M2683	DIN00	690	160	1
CH4	0087	9.66	174	170M2683	DIN00	690	160	1
CH4	0105	8.01	210	170M2683	DIN00	690	160	1
CH4	0140	6.01	280	170M4199	1SHT	690	400	1
CH5	0168	5.00	336	170M4199	1SHT	690	400	1
CH5	0205	4.10	410	170M4199	1SHT	690	400	1
CH5	0261	3.22	522	170M4199	1SHT	690	400	1
CH61	0300	2.80	600	170M6202	3SHT	690	500	1
CH61	0385	2.18	770	170M6305	3SHT	690	700	2
CH62	0460	1.83	920	170M6277	3SHT	690	1000	2
CH62	0520	1.62	1040	170M6277	3SHT	690	1000	2
CH62	0590	1.43	1180	170M6277	3SHT	690	1000	2
CH62	0650	1.29	1300	170M6305	3SHT	690	700	3
CH62	0730	1.15	1460	170M6305	3SHT	690	700	3

Table 118. Brake chopper unit fuse selection (Bussman aR), mains voltage 640–1100 Vdc

Chassis	Type	Min resistor value, 2* [ohm]	Braking current	DIN43620		Fuse U _n [V]	Fuse I _n [A]	Qty. of fuses per pole
				aR fuse part nr.	Fuse size ¹			
CH61	0170	6.51	340	170M6305	3SHT	1250	700	1
CH61	0170*	80	27	170M2679	DIN00	1000	63	1
CH61	0208	5.32	416	170M6277	3SHT	1250	1000	1
CH61	0208*	30	73	170M2683	DIN00	1000	160	1
CH61	0261	4.24	522	170M6277	3SHT	1250	1000	1
CH61	0261*	12	183	170M4199	1SHT	1250	400	1
CH62	0310	3.41	650	170M6305	3SHT	1250	700	2
CH62	0385	2.88	770	170M6277	3SHT	1250	1000	2
CH62	0416	2.66	832	170M6277	3SHT	1250	1000	2
CH62	0460	2.41	920	170M6277	3SHT	1250	1000	2
CH62	0502	2.21	1004	170M6277	3SHT	1250	1000	2

¹ SHT fuses can be assembled into DIN fuse base of the corresponding size

VACON[®]

www.danfoss.com

Vacon Ltd
Member of the Danfoss Group
Runsorintie 7
65380 Vaasa
Finland

Document ID:



DPD00887E

Rev. E

Sales code: DOC-INSNXPLC+DLUK